



CHAPTER 6

FIRE FIGHTING SYSTEMS

6.1 PORTABLE EXTINGUISHERS

6.1.1 *General*

- (a) All Purpose Groups, except Purpose Groups I shall be provided with portable fire extinguishers.
- (b) Portable fire extinguishers where required to be provided shall be constructed in conformity with specifications stipulated under BS EN 3 Specifications for Portable Fire Extinguishers.
- (c) All portable fire extinguishers where required to be provided shall be charged, tested and maintained in fully operational conditions and properly tagged in conformity with requirements in BS EN 3, Code of Practice for Use and Maintenance of Portable Fire Extinguishers.

6.1.2 *Type, size and siting*

Classification of portable fire extinguishers provided shall be selected in accordance with criteria specified under BS EN 3, such that the nature of processes and contents within the building concerned can be effectively protected. The size, quantity and siting of these portable fire extinguishers shall comply with the requirements in BS EN 3, under the respective class of occupancy hazard

6.1.3 *Installation, marking*

Portable fire extinguishers provided shall be installed and conspicuously marked in accordance with requirements by BS EN3.

6.2 RISING MAIN AND HOSE REEL SYSTEMS

6.2.1 *Type of Rising Main*

- (a) The type of rising main system shall be provided appropriate to the building as follows:
 - (i) dry rising main shall be installed in buildings under Purpose Groups II, III, IV, V, VI, VII and VIII where the habitable height is more than 18m, but does not exceed 30m,



- (ii) wet rising main shall be installed in buildings with habitable height exceeding 30m,
 - (iii) separate dry and wet rising main systems in a building are permitted.
- (b) Notwithstanding the requirements in sub-clause (a), dry rising main conforming to BS 9990, shall be provided to any part of a single or multiple level basements.
- (c) Where the building has access from more than one ground level or road level, the height measurements for the purpose of this code shall be taken from the level of access way or fire engine access road (applicable to buildings under Purpose Group II) provided.

6.2.2 *Number, Location and Size of Rising Mains*

- (a) The number and distribution of rising mains shall comply with the requirements stipulated in BS 9990 Code of Practice for Fire Hydrant systems and Hose Reels.
- (b) Position of rising mains and the associated landing valves shall be kept free of obstruction both physically and visually and located:
- (i) within fire-fighting lobby, smoke-stop lobby or external corridor immediately outside the door of the exit staircase;
 - (ii) in the case where there are no fire-fighting lobby, smoke-stop lobby or external corridor, it shall be located inside exit staircase, or in the common area and within a protected shaft, immediately outside the door of the exit staircase.

Note: Where there are provisions of fire-fighting lobby or smoke-stop lobby within the building, the position of rising mains and landing valves shall first be located inside fire-fighting lobby.

- (c) Size of rising mains shall comply with BS 9990
- (d) Location and provision for landing valves shall comply with BS 9990.
- (i) Landing valve is not required to be provided at the 1st storey level to buildings under Purpose Group II if the breeching inlets are installed in accordance with clause 6.2.3(c).



(ii) Where all the exit staircases in a building under Purpose Groups III to VIII are installed with rising mains and standby fire hoses, and yet part of a floor space is beyond the 25m coverage of any landing valve, an additional standby fire hose shall be provided at the landing valve nearest to this floor space.

(e) Installation of rising main shall comply with BS 9990.

6.2.3 *Breeching inlets and Access ways*

(a) All buildings fitted with rising mains shall have access ways or fire engine access road (only applicable to buildings under Purpose Group II) for pumping appliances within 18m of the breeching inlet. The breeching inlets shall be visible from the access ways or fire engine access road.

(b) Requirements and provisions for breeching inlets for the rising main system shall be in accordance with the BS9990 Code of Practice for Fire Hydrant systems and Hose Reels. Connecting pipe between the inlets and the vertical run of the rising main, where applicable, shall be kept as short as possible.

6.2.4 *Wet Rising Main*

(a) Capacity of the water supply from the public mains and the storage capacity for a wet rising main system shall comply with the requirements in BS 9990, Code of Practice for Fire Hydrant systems and Hose Reels.

(b) Flow

Flow requirements for wet rising main system shall comply with those stipulated in BS 9990.

(c) Running Pressure

Running pressure at each discharging landing valve on the wet rising main system shall be maintained between the minimum and maximum values as stipulated in BS 9990.

(d) Static Pressure

Static pressure in any line of hose connected to a landing valve in a wet rising main system shall not exceed the specified value in BS 9990.

(e) The location of storage tank and capacity of break tank where required shall comply with the requirements in BS 9990.



- (f) Installation of fire pumps for wet rising main system shall comply with requirements of BS 9990. Wet riser pumps shall be installed within a fire compartmented fire pump room, whose fire rating shall be in accordance with Table 6.4A. The fire pump room floor level shall not be lower than the main floor level.

6.2.5 Standby Fire Hose For Rising Main

Standby fire hose shall be provided for every rising main. The following requirements shall be complied with:

(a) Type and Folding Method

- (i) The standby fire hose shall be of 65mm nominal internal diameter in order to ensure that the hose coupling will fit existing coupling tail pieces. The hose shall be rugged and capable of carrying water under substantive pressure in accordance with BS 6391. The fire hose shall be Type 3 as stipulated in the BS 6391.
- (ii) The fire hose couplings shall be manufactured to BS specification or equivalent and of light alloy or gunmetal. The coupling shall be of type 65mm and be of the instantaneous type with standard (double-pull) release mechanism. The couplings shall be tied in by binding with galvanized mild steel wire or any other acceptable means and applied over a hose guard of synthetic fibre. It shall be able to withstand a minimum working pressure of 15 bars.
- (iii) Each hose shall have a standard length of 25m and shall be kept stowed in a Dutch Rolled position and housed in a glass fronted cabinet. The Dutch Roll shall be rolled in the manner shown in Diagram 6.2.5 (a).

(b) Position

- (i) The fire hose shall be installed just next to, but not more than 2m from the landing valve as shown in Diagram 6.2.5(b).
- (ii) The entire fire hose and cabinet shall be out of direct sunlight.

(c) Mounting

The wall mounted fire hose and cabinet shall be as follows:

- (i) The cabinet shall be firmly mounted on the wall and rigid to take either one or two fire hose weight.
- (ii) The cabinet shall be constructed of non-combustible material and maintenance free.



- (iii) The cabinet lock, if provided, shall be one of the type that could be operated manually from the inside without the use of a key when the front plain glass/ plastic (minimum 300mm x 300mm) is broken by the fire-fighter.
 - (iv) The cabinet swing door shall be made openable such that it will not obstruct the retrieving of the fire hose by the fire-fighter.
 - (v) The depth of the cabinet shall not exceed 250mm for one fire hose or 350mm for two fire hoses.
 - (vi) The cabinet shall be painted in a contrasting colour such that it is conspicuous and easily identified.
 - (vii) The wording, "FIRE HOSE" with letter height of at least 50mm and shown in contrasting colour, shall be painted directly on the front panel as shown in Diagram 6.2.5(b).
 - (viii) In lieu of the cabinet, simple wall mounted cradle for the fire hose can be provided, but only in the riser main shaft. The cradle shall be constructed and position to facilitate the retrieving of fire hose by the fire-fighter.
 - (ix) The cradle (in lieu of the cabinet) shall be maintenance free. The fire hose installation height shall be limited as indicated in Diagram 6.2.5(b)
- (d) General
- (i) Only clean, dry and compact rolled (roll from female coupling) and hose shall be placed in the cabinet.
 - (ii) BS 6391 stipulates the technical requirements for quality acceptance standards of the fire hose. In addition, the abovementioned requirements shall be applicable for acceptance of the standby fire hose.

6.2.6 Building under construction

When a building in pursuance of Cl.6.2.1, is required to be equipped with rising mains, such rising mains shall be installed progressively as the building attains height during the course of construction. All outlets, landing valves and inlets, water tanks and pumps, and hydrants as may be required for the system, shall be properly installed as directed by the MFRS so as to be readily operational in case of fire. Please see Appendix (3) on fire safety requirements for buildings under construction.



6.2.7 *Foam inlets*

Where boiler room/s or storage room/s containing highly combustible materials are located in basement or not easily accessible for firefighting, foam inlets and pipe works shall be provided for the purpose of delivering foam solution to an area close to the room/s concerned. A 2-way breeching inlet shall be provided at ground level with pipe run of minimum 100mm bore terminating in landing valve just outside the high fire risk room/s. The provision of the breeching inlet shall comply with the relevant clauses of BS 9990.

In situations where such rooms have access openings along access way, provision of foam solution inlets and outlets is not required

6.2.8 *Hose Reels*

(a) Hydraulic hose reel conforming to the requirements in BS 9990. Code of Practice for Fire Hydrant Systems and Hose Reels shall be provided in every storey of every building regardless of building height, except the following:

- (i) Purpose Group I buildings;
 - (ii) Non-residential occupancy at the 1st storey of a residential building, and fulfilling the following conditions:
 - (1) Floor area of the shop or office unit does not exceed 150m²;
 - (2) Compartmented from the residential floors and other parts of the building;
 - (3) Not being used as an eating establishment, storage of flammable materials;
 - (4) Not being used as public entertainment outlet;
 - (5) Not belonging to Purpose Group VI & VIII.
 - (iii) Any other small stand-alone single-storey guardhouse, bin centre, electrical sub-station and open-sided shed not exceeding 200m² (excluding those in Purpose Group VI & VIII).
 - (iv) Subject to compliance with Cl.2.6.2, provision of hose reel on the mezzanine floor of factory unit is not required provided the coverage distance of the nearest hose reel at the main floor to the most remote point of the mezzanine floor shall not exceed 36m.
- (b) The hose shall be of 20mm or 25mm nominal diameter and conform to EN 694, not exceeding 30m in length and terminating in 'shut-off' branches with 4mm or 6mm nozzles

**(c) Water supply**

Water supply for hose reels in terms of flow rate and minimum running pressure shall comply with the requirements in BS 9990.

d) Siting & installation

Siting and details of installation for hose reels shall comply with the requirements in BS 9990.

- e) The use of copper or stainless steel piping is permissible for the connection of the hose reel to the CWA mains.

6.2.9 Graphical symbols to depict fire safety equipment are allowed for use in buildings provided the signs comply with BS ISO 3864. The Table below shows the different size of the graphical symbol with respect to the viewing distance.

Table 6.2.9A

Viewing Distance	0m to 6m	>6mto9m	>9mto12m	12 ormore
Z=100	min. 60mm	min. 90mm	min. 120mm	min. 150mm

Note: The luminous factor (Z) from BS 5266 is used to determine the size of the sign. It essentially dictates the size of the sign that varies with distance. The graphical symbol for fire-fighting equipment shall be sized such that the height and width are same. The size of symbol is not inclusive of borders

6.3 ELECTRICAL FIRE ALARM SYSTEM

6.3.1 General

- (a) Every building or part of a building, except that of Purpose Group I (residential floors), having a total floor area of more than that specified in Column B of Table 6.3A having regard to the purpose group of the building or part of the building, shall be installed with a fire alarm system, either of the automatic or manual type as indicated in Column C, which shall be an electrically supervised system complying with the requirements of the BS 5839, and shall be connected to a fire station through an approved alarm monitoring station if required under Cl.6.3.7

(b) Group II mixed occupancy

- (i) For a building of mixed commercial-cum-residential usage, the residential floors located on the upper storeys of the building shall be provided with manual alarm system at the common area.

If the habitable height of the building does not exceed 24m, only the alarm sounder of the fire alarm system need be extended to the common lobby area of each residential floor



Group II with lower car park floors

- (ii) For residential developments which are located over car parks (irrespective of whether the car parks are in the basement) where fire alarm system is required under Table 6.3A, the alarm bells of the fire alarm system shall be extended to the common lobby area of each residential floor, irrespective of the height of the building.
- (c) Notwithstanding (a) above, if the total floor area per storey of a 2 to 4 storey building of any of the Purpose Group III to VIII exceeds the sizes as stipulated in Column (2) of Table 3.2A, the building shall be provided with an automatic fire alarm system.
- (d) For dormitories, including workers' dormitories, electrical fire alarm system shall be provided as follows:
 - (i) dormitories not exceeding 4-storey, manual fire alarm system is to be provided to comply with BS 5839;
 - (ii) dormitories exceeding 4-storey, automatic fire alarm system shall be provided to comply with BS 5839.

6.3.2

Fire alarm panel

- (a) An electrical fire alarm system of the automatic or manual type shall be provided with a fire alarm panel to indicate the location of the alarm which has been actuated or operated. Such alarm panel of location shall be accurate to the maximum allowed alarm group area limitations specified in BS5839,
- (b) The associated control and supervisory equipment, indicating equipment, wiring and arrangement of power supplies for the fire alarm panel shall comply with the requirements in BS 5839.
- (c) All automatic systems which are activated via the general building alarm shall be connected directly to the fire alarm panel
- (d) The fire alarm panel should be located near the main entrance of the building, in the fire command centre, in the guardhouse or in the firefighting lobby, if provided, or as may be required by the MFRS.
- (e) Sub fire alarm panel, where provided, shall comply with the requirements in BS 5839, be located at the fire-fighting lobby, smoke-stop lobby, protected staircase in that order of priority or at the main point of entry into the area covered by the alarm zone.



6.3.3 *Manual Alarm Call Points*

- (a) In a manual alarm system, except as otherwise exempted in Cl.6.3.1, the manual call points shall be provided on every storey of the building or part of the building and shall be so located that no person need travel more than 30m from any position within the building to activate the alarm.
- (b) Manual call points should be located on exit routes preferably next to hose reels and in particular on the floor landings of exit staircases and at exits to the street. In the case where an automatic fire alarm system is provided, grouping for indication of location of the manual call points shall comply with the requirements in BS 5839.
- (c) Manual call points should be fixed at a height of 1.4m above the floor and shall be located at easily accessible and conspicuous positions free from obstructions. The installation of the sounding device shall be in accordance with BS5839.
- (d) Manual break-glass alarm call points can be omitted in car parks, irrespective whether the parking facility is stand-alone type or forms part of a building.
- (e) Subject to compliance with Cl.2.6.2, provision of manual call point on the mezzanine floor of factory unit is not required provided no person on the mezzanine floor need to travel more than 30m to activate the nearest manual call point located on the main floor.

6.3.4 *Automatic fire alarm*

Where an automatic fire alarm system is required by this Code, the type, location, spacing and installation of the detectors shall comply with the requirements in BS 5839.

6.3.5 *Alarm Device*

- (a) The alarm device, which should normally issue an audible signal unless specifically allowed or required otherwise by the MFRS, shall be actuated if the electrical fire alarm system is activated or operated. The type, number and location of the alarm device shall comply with the requirements in BS 5839.
- (b) The fire alarm sounder shall have a sound that is readily distinguishable from any other alarm system.
- (c) All sounders in the building should be actuated simultaneously in the event of an activation. However, in cases permitted or required by the MFRS where the operation of alarm sounders are grouped or activated in stages, the arrangement shall comply with the requirements in BS5839.



(d) Visual alarm signal

- (i) In discos, night clubs, other places of entertainment outlets or areas where audible alarms may be ineffective (background noise is excessive), visual alarm signals shall be provided. In general, visual signals shall not be used in place of audible alarms. The intensity of the light shall be sufficient to draw the attention of people in the vicinity, or
- (ii) The sound system in discos, night clubs and other places of entertainment shall be electrically interlocked with the fire alarm system to enable the sound to be automatically cut-off in the event that the fire alarm system is activated.

6.3.6 Alarm system for cinema

A theatre or cinema shall be provided with an electrical fire alarm system of the manual type complying with the following:

- (a) The manual alarm system shall be installed in the lobbies and other areas adjoining the hall and shall be connected to a fire station through an approved alarm monitoring station, and
- (b) Visual and audible alarm indicators shall be installed in the projection room and in another room where a responsible person is readily available to alert the audience in case of a fire, and
- (c) The provision of the fire protection system in cinema which forms part of the building shall be similar to that of the building.

6.3.7 Connection to fire station

The electrical fire alarm system required to be installed in a building or premises under this clause shall be connected to a fire station through an approved alarm monitoring station when the building or premises is

- (a) Health care occupancy, hotel or other such like occupancy,
- (b) An oil refinery, oil depot, general warehouse, chemical plant or other high hazard factory or premises,
- (c) A theatre, cinema or concert hall as specified in Cl.6.3.6, or
- (d) (i) A building required under the provisions of this code to be protected by an automatic fire alarm or fire extinguishing system.
(ii) Notwithstanding the provision in Cl.6.3.3(d) if a car park in a building is provided with both manual and automatic fire alarm system, then the manual fire alarm need not be connected to the fire station through an approved alarm monitoring company.



6.3.8 *Sprinkler protected building*

Where sprinkler system is required by this Code, provision of automatic thermal/smoke detectors in sprinkler protected premises will be exempted except where such detectors are required to activate or operate the sprinkler or other systems.

6.4 **SPRINKLER INSTALLATION**

6.4.1 General

The following shall be provided with an automatic sprinkler system:

- (a) Whenever compartmentation requirements under Chapter 3 of this Code cannot be complied with.
- (b) Every storey of a building, except that of Purpose Group I or II, the habitable height of which is more than 24m irrespective of whether or not the compartmentation requirements are complied with.
- (c) In the case of Purpose Group II occupancy forming the upper storeys of a building of mixed occupancy with habitable height exceeding 24m, every storey of the non-residential portion only, shall be provided with an automatic sprinkler system.
- (d) Basement
 - (i) All basement storeys, except for those used as Purpose Groups I or II, shall be provided with an automatic sprinkler system irrespective of compartment size. Where the upper storeys of the building is fully compartmented from the basement storey, the requirement for provision of an automatic sprinkler system for floors above the basement shall be considered separately and in accordance with sub. Cl.6.4.1(a), (b) and (c).
 - (ii) Where the basement storey is effectively cross-ventilated such as to avoid smoke logging conditions, the basement storey may be exempted from the requirements of provision of an automatic sprinkler system, at the discretion of the MFRS.
 - (iii) In the case of residential development located over basement car park, relaxation on the provision of these sprinkler system and smoke purging systems to the basement car park may be granted by the MFRS, if the following conditions are satisfactorily fulfilled:
 - (1) basement car parking shall consist of one level only;
 - (2) external openings shall be provided to achieve effective cross-ventilation by means of evenly distributed vertical openings along the perimeter walls and evenly distributed voids over the basement in such manner that:



- no point within the basement is more than 12m from any vertical opening or void for spaces that are in between two openings or voids;
 - no point shall be more than 6m from any opening or void for spaces that are ventilated by such opening or void on only one side; and
 - such vertical openings shall be at least 600mm in height;
- (e) total aggregate area of these voids and vertical openings shall be not less than 20% of the total basement floor area;
- (f) automatic fire alarm system shall be provided to the basement car parks with extension of alarm bells to the common/lobby areas of the upper storeys in accordance with Cl.6.3.1(a) and (b) (ii).
- (g) Exemption of sprinkler protection

With the exception of industrial buildings, such as factories (Purpose Group VI), warehouses and storage depots (Purpose Group VIII), the following areas are exempted from sprinkler protection in a sprinklered building

(i) Canopies/Car porches

- (1) Such areas are used solely for the purpose of passengers pick-up and drop-off point; and
- (2) There shall be no commercial activities or storage within these areas; and
- (3) Cut-off sprinklers and fire rated wall are not required to be provided to separate the sprinklered and non-sprinklered areas.

(ii) External corridor

External corridors not exceeding 4m in width, provided there is no commercial activities or storage within these areas.

(iii) Atrium ceilings

Atrium ceilings which exceed the height of 12m, measured from the finished floor level of the atrium floor to the ceilings of the atrium roof or to the level of half the vertical height of the ceilings of the atrium roof in the case of irregular roof profile. In lieu of the provision of sprinklers, approved effective detectors (e.g. smoke, infra-red, etc.) shall be installed in accordance with the approved standards and there shall be no commercial activities or storage within the floor spaces below the atrium roofs

(iv) External link way

External open-sided link ways not exceeding 5m in width, provided there is no commercial activities or storage within these areas.



6.4.2 *Installation*

Installation of the sprinkler system and its associated water supply, control and testing requirements shall comply with the BS EN 12845.

6.4.3 *Connection to fire station*

- (a) The sprinkler system shall be electrically monitored so that on the operation of any sprinkler head, the fire signal is automatically transmitted to a fire station through an approved alarm monitoring station.
- (b) Installation of fire pumps for sprinkler system shall comply with requirements of BS EN 12845. Sprinkler pumps shall be installed within a fire compartmented fire pump room, whose fire rating shall be in accordance with Table 6.4A. The sprinkler pump room floor level shall not be lower than the main floor level.

Sprinkler control valve(s) shall be located in the following order of priority:

- (i) facing external within close proximity to Fire Command Centre;
- (ii) within fire-fighting lobby/smoke-stop lobby; and
- (iii) within sprinkler pump room that has proper access; and
- (iv) within fire compartmented enclosure located near to fire-fighting stair and readily accessible from the common areas.

6.4.4 *Special Purpose Rooms*

- (a) Where a building is required to be provided with an automatic sprinkler system under this Code, parts of the building which are used for purposes stipulated in Table 6.4A shall be compartmented in accordance with columns 3(a) and 3(b) of the table. Exemptions of sprinkler provision for such rooms or spaces are indicated (Ex) in column 3(c) of the table.
- (b) Where a building is not required to be provided with an automatic sprinkler system under this Code, special purpose rooms stipulated in Table 6.4A shall be compartmented in accordance with columns 2(a) and 2(b).
- (c) Where automatic sprinklers are to be replaced by an automatic fire extinguishing system to protect special purpose rooms for the use as communication nerve centres, data process centres and process control rooms composing of high value computers or telecommunication equipment, the enclosure to the hazard or occupancy shall comply with the following:
 - (i) it shall be constructed to have minimum 1-hour fire resistance rating;
 - (ii) any door opening shall be protected with minimum 1-hour fire door;



- (iii) it shall not be provided with more than 2 exits;
- (iv) the direct travel distance to any exit door of the enclosure shall not exceed 15m; and
- (v) The fire extinguishing system using clean agent shall conform to Cl.6.5.2

6.4.5 *Water mist system*

Water mist system may be permitted as a substitute of automatic sprinklers in sprinkler protected buildings provided that the following requirements are complied with :

- (a) Water mist system shall be a propriety design that has been tested to meet the performance requirements of a standard acceptable to the MFRS;
- (b) Design and installation of water mist system shall conform to BS 8458
- (c) Components of water mist system shall be listed by a recognised testing laboratory.

6.4.6 In multi-storey buildings under Purpose groups II, III, IV, V, VI, VII & VIII not exceeding 24m in habitable height, where any car parking area above ground is provided with natural ventilation in accordance with Cl.3.2.8(c), the provision of automatic sprinkler to the car parking area is not required provided:

- (a) An automatic fire alarm system shall be provided to the car parking area under Purpose Groups III, IV, V & VII; and
- (b) Manual fire alarm system shall be provided to the car parking area under Purpose Group II subject to Table 6.3A.

6.4.7 The “Guidelines on Reduced Water Storage for Automatic Fire Sprinkler System in Buildings” are given in Appendix (9). It provides an acceptable design approach for the installation of sprinkler systems in both new and existing buildings under ordinary hazard category classification under BS EN 12845

6.5 **FIXED AUTOMATIC FIRE EXTINGUISHING SYSTEMS**

6.5.1 *Installation*

Installation of any fixed automatic fire extinguishing systems which are not deemed to be required by this Code shall not be accepted as substitute of any provision stipulated in this Code unless otherwise approved as such by the MFRS. Such systems will be considered as additional protection for property safety and their installation shall not adversely affect the performance of the stipulated systems.

6.5.2 Design and installation of such automatic fire extinguishing systems shall comply with corresponding Code of Practice acceptable by the MFRS.



6.6 LIFTS

A set of requirements using lifts for building evacuation during emergency is drawn up at Appendix 18 & Appendix 19. These requirements are applicable to all buildings except residential developments.

6.6.1 *Hoist way ventilation*

Lift hoist ways shall be vented in accordance with the BS EN 81-20.

6.6.2 *Emergency Power Supply*

- (a) Emergency power supply for lighting, ventilation and alarm systems for all passenger lifts shall comply with the requirements in BS EN 81-20
- (b) Buildings which require the provision of standby generating plant for special emergency operations.

Provision for special emergency operation for lifts shall comply with the requirements in BS EN 81-20, for the following:

- (i) Public buildings;
 - (ii) Buildings under Purpose Group II exceeding the habitable height of 60m;
 - (iii) Buildings under Purpose Group II where the passenger lifts serve the upper storey residential floors and the non-residential basement;
 - (iv) Mixed developments where the passenger lifts serve both the residential and non-residential floors;
 - (v) Industrial buildings under Purpose Group VI and VIII, which are multi-storey
 - (vi) All basement occupancies.
- (c) The power supply to the lift shall be connected to a sub main circuit exclusive to the lift and independent of any other main or sub main circuit. The power cables serving the lift installation shall be routed through an area of negligible fire risk.

6.6.3 *Fire Lift*

- (a) With the exception of Purpose Group I and II buildings, all other buildings shall be provided with at least two fire lifts if the habitable height exceeds 24m. See Appendix 19 on the design details

For Purpose Group II buildings, at least one fire lift shall be provided if the habitable height exceeds 24m.



All buildings shall also be provided with at least two fire lift if the depth of the basement exceeds 9m below the average ground level.

The fire lift(s) shall be contained within a separate protected shaft or a common protected shaft containing other lifts subject to such other lifts being served at each storey by the fire fighting lobby, which is required by the provisions of Cl.2.2.13(b) of this Code

- (b) A fire lift shall be adjacent and accessible to an exit staircase and be approached by a fire-fighting lobby at each storey. The fire lift shaft shall be continuous throughout the building and serve every storey
- (c) Fire lift shall be provided with an operational feature that would enable firemen to cancel first or earlier call which had been inadvertently made to the fire lift during an emergency. This operational feature could be built into the lift control system or alternatively a separate by-pass switch could be provided. If the operational feature is built into the lift control, it is not mandatory to provide a separate by-pass switch.
- (d) A lift mainly intended for the transport of goods shall not be designated as a fire lift.
- (e) The installation of the fire lift shall be in accordance with BS EN 81-20
- (f) The fire lift shall be located such that any part of every storey shall be accessible to fire-fighters from the fire lift.
- (g) Regardless of whether the building is installed with automatic sprinkler system, the number of fire lifts required shall be such that any part of a storey of the building is within 60m coverage from the fire lift door; subject to provisions of at least 2 fire lifts in accordance with sub-clause (a).

6.6.4

Homing of lifts

- (a) Homing of lifts for buildings which are required to be provided with fire alarm system. In a fire emergency when any one of the fire detection devices or fire alarm systems is activated, all the passenger lifts shall be brought to the designated floor (usually) 1st storey) and park there with the lift landing doors remaining opened.
- (b) Homing of lifts for buildings which are required to have standby generating plant.

In the event of power failure or power interruption in the building, the supply to the lifts shall be automatically switched over to the emergency power supply from the generating plant and the lifts shall be brought to the designated floor and park there with the lift landing doors remaining open until all the lifts have been brought down to the designated floor. Thereafter, one or more lifts may resume operation depending on the capacity of the emergency generating plant, in addition to the fire lift. Normal operation of the lift shall be automatically reset on the return of normal power supply.



- (c) Homing of lifts for buildings which are not required to have standby generating plant.

All passenger lifts, including hydraulic lifts, shall be provided with Automatic Rescue Device (ARD). The ARD shall permit the lifts to move and park at the nearest lift landing floor with the lift/landing doors in the opened position in the event of power failure. Homing any of the lifts to a basement storey is not permitted.

- (d) Homing of lifts for Mixed developments comprising residential and non-residential components

(i) All passenger lifts which serve the residential and non-residential floors shall be required to home to the designated or alternative designated floor in the event of power failure and/or fire. The lifts shall be provided with secondary power supplies from standby generating plant of sufficient capacity.

(ii) Where the passenger lifts serve only the residential floors and by-pass the non-residential floors in a protected shaft, the lifts shall be required to be installed with Automatic Rescue Device (ARD), provided the habitable height of the highest floor does not exceed 60m.

(iii) Where the passenger lifts serve the upper residential floors and the basement non-residential floor/s, including car parks, the lifts shall be provided with emergency power supply from standby generating plant for homing to the designated floor when there is a power failure in the building. In a fire emergency, the passenger lifts shall be brought to the designated floor when any of the fire alarm system in the basement non-residential floor/s is activated.

- (e) Alternative designated floor

(i) Where the lifts open directly into an occupancy area in a designated floor, for example, a shopping floor or an office floor, an alternative designated floor (e.g. 2nd storey) shall also be identified. The lifts shall be brought to the alternative floor in the event that there is a fire in the designated floor, in close vicinity of the lift landing door. The activation of any detector or sprinkler head covering the lift landing space at the designated floor would cause the lift to be re-directed to home to the alternative floor.

(ii) The alternative floor shall have minimum fire hazard and pre-selected for the homing of passenger lifts, and where people can escape to safety in an exit staircase or other exit from the lift landing door.



- (iii) In building under (e)(i) which are not provided with sprinkler or automatic fire alarm system, suitable sensors shall be provided at ceiling level to cover the lift landing space. The activation of any sensor would cause the lifts to be re-directed to home to the alternative floor.
- (iv) The above requirements on homing of lifts to an alternative floor need not be applied to standalone open-sided car park and residential buildings under Purpose Group I.



Diagram 6.2.5(a)

STEP 1

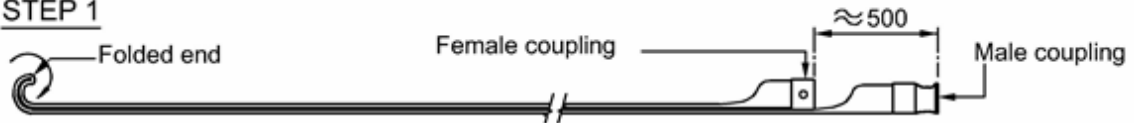

- a. Fold the fire hose into half with the male and female coupling around 500mm apart.
- b. Roll the fire hose at the "folded" end, not coupling end.

STEP 2



- c. Ensure the fire hose is rolled in a compacted manner

STEP 3

- d. A velcro strap is required to be secured on the Dutch Roll Fire Hose as indicated
- e. Place the fire hose into a cabinet as shown in figure 1

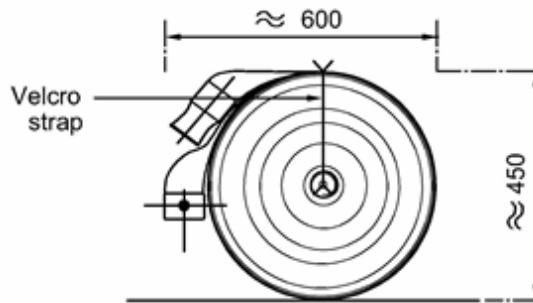

Dutch Roll Folding Method



Diagram 6.5.2 (b)

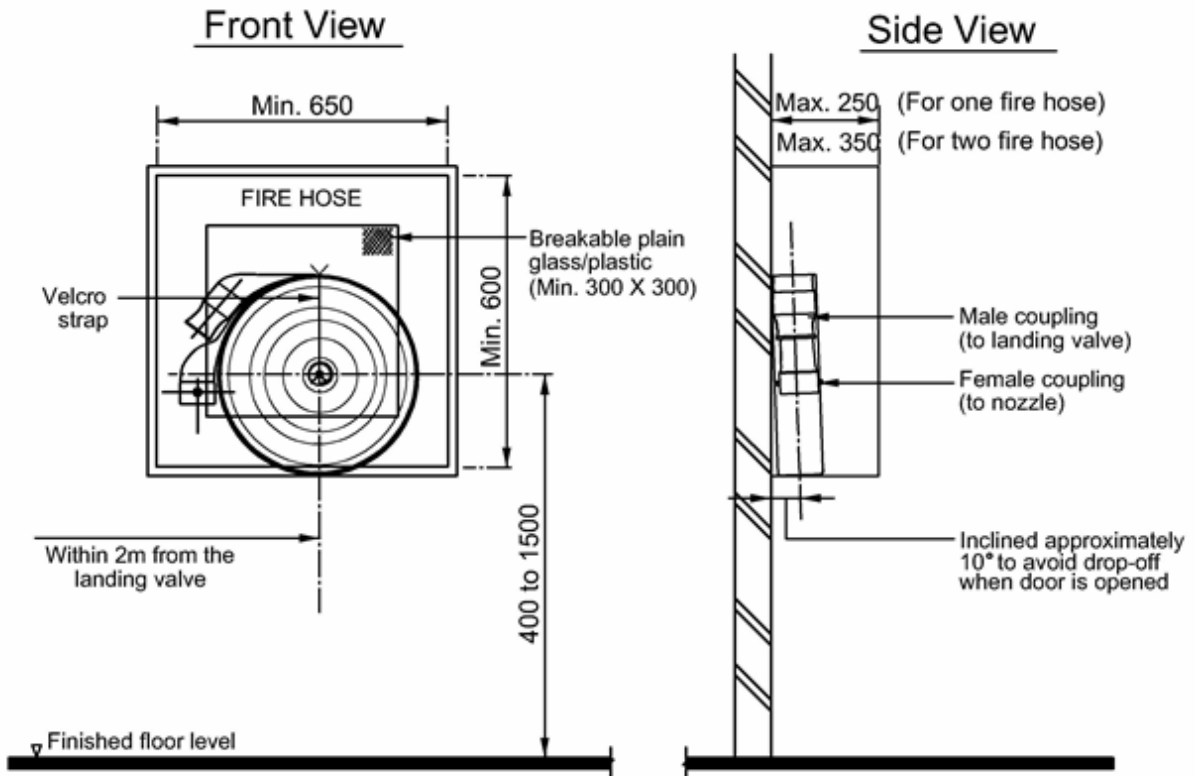

**Dutch Rolled Fire Hose With Cabinet
(surface mounted or recessed)**

(All dimensions in mm unless otherwise indicated)



**TABLE 6.3A - PROVISION OF FIRE ALARMS ACCORDING TO PURPOSE GROUP,
HEIGHT & SIZE OF THE BUILDING**

A	B	C
Purpose group & No of storeys of building	Total floor area (per storey in sq m) in excess of which alarm must be provided	Type of Alarm
III (Institutional)		
(i) Schools & others		
a - Single storey building	NL	-
b - Building of 2 to 4 storey	400‡	(m)+
c - Building of more than 4 storeys	400**	(a)
(ii) Health care occupancy with stay-infacilities		
a - Single storey building	NR	(m)
b - Building of 2 to 4 storeys	NR	(a)
c - Building of more than 4 storeys	NR	(a)
(iii) Health care occupancy without stay-infacilities		
a - Single storey building	NL	-
b - Building of 2 to 4 storeys	200‡	(m)
c - Building of more than 4 storeys	NR	(a)
(iv) Dormitories		
a - Single storey building	NR	(m)
b - Building of 2 to 4 storey	NR	(m)
c - Building of more than 4 storeys	NR	(a)
IV (Office)		
a - Single storey building	400*	(m)
b - Building of 2 to 4 storey	200‡	(m)
c - Building of more than 4 storeys	NR	(a)
V (Shop)		
a - Single storey building	400*	(m)
b - Building of 2 to 4 storey	200‡	(m)
c - Building of more than 4 storeys	NR	(a)
VI (Factory)		
a - Single storey building	400*	(m)
b - Building of 2 to 4 storey	200‡	(m)
c - Building of more than 4 storeys	NR	(a)
VII (Place of Public Resort)		
(i) With stay-in facilities i.e.hotels,boarding houses, serviced apartments,hostels, backpackers hotel		
a - Single storey building	NR	(m)
b - Building of 2 to 4 storey	NR	(m)
c - Building of more than 4 storeys	NR	(a)
(ii) Without stay-infacilities		
a - Single storey building	400*	(m)
b - Building of 2 to 4 storey	200‡	(m)
c - Building of more than 4 storeys	NR	(a)
VIII (Storage)		
a - Single storey building	2000*	(m)
b - Building of 2 to 4 storey	1000‡	(m)
c - Building of more than 4 storeys	NR	(a)

Single storey building with area less than indicated is not required to be provided with alarm system unless otherwise specified by the MFRS.

** Building of more than 4 storeys but area less than 400sqm, only manual alarm system is required.

+ Where used for sleeping accommodation, automatic alarm system may be required by the MFRS.

‡ The total floor area per storey shall not exceed that as stated in Cl.6.3.1(c).

NL =no limit (m) = manual type

NR =not relevant (a) = automatic + manual type

Remarks: (1) When there are 2 or more purpose groups in a building, the strictest requirement for any one of the purpose groups shall be applicable to the whole building.

(2) Where purpose group II forms part of a mixed use building, Cl.6.3.1(b)(i) shall be followed.

**Table 6.4A - Compartmentation requirements for special purpose rooms in buildings**

Usage (1)	Non-sprinkler protected building (2)		Sprinkler protected building (3)		
	Compartment (2a)	Door rating (2b)	Compartment (2a)	Door Rating (3b)	Sprinkler (3c)
Store room ¹	1 hr	1 hr	N	N	S
AHU room ³	N	N	N	N	S
Kitchen ²	1 hr	1/2 hr	1 hr	1/2 hr	S
Boiler room (oil fired)	2 hr	2 hr	1 hr	1 hr	S
Low voltage Switch room	B	B	B	B	Ex
High voltage Switch room	B	B	B	B	Ex
Transformer room (oil type)	B	B	B	B	Ex
Oil Tank room	2 hr	2 hr	1 hr	1 hr	S
Generator room	2 hr	2 hr	1 hr	1 hr	S
A/C Plant room	2 hr	2 hr	1 hr	1 hr	S
Electric Lift motor room	2 hr	2 hr	2 hr	2 hr	Ex
Hydraulic Lift motor room	2 hr	2 hr	1 hr	1 hr	S
Essential Fan room	2 hr	2 hr	1 hr	1 hr	S
Electrical room	2 hr	2 hr	2 hr	2 hr	Ex
Battery room	2 hr	2 hr	2 hr	2 hr	Ex
Sprinkler/Wet Riser Tank room	B	B	B	B	S
Fire Pump room	B	B	B	B	S
Fire Command centre	2 hr	2 hr	2 hr	2 hr	S
MDF room	N	N	B	B	Ex
			N	N	S
PABX room	N	N	B	B	Ex
			N	N	S

Compartmentation and door rating in this table are specified in one of the following ways:

- N = no specific requirement on compartmentation
 B = compartmentation and door rating of the special purpose room shall not be less than the fire resistance of the elements of structure of the building where the room is located

The fire resistance rating stipulated in this table shall be the minimum.

Requirement for sprinkler in the special purpose rooms is specified in one of the following ways:

- S = Sprinkler system has to be extended into such rooms
 Ex = Sprinkler system is exempted from the corresponding area provided the area is fitted with an automatic fire alarm system installed according to BS5839-1

- Requirements stated herein apply to store room which is required to be compartmentalized
- Requirements stated herein apply to kitchens in hotel, restaurant, coffee house or other similar places where the preparation of food is required. However, special considerations will be given to the followings
 - kitchens where 'open flame' cooking appliances are NOT used, or
 - kitchens where all the cooking facilities are fitted with approved extinguishing systems.
- Where AHU rooms are vertically stacked, each AHU room shall be separated by a compartment floor at every level. In the case of AHU serving more than one compartment, fire dampers shall be provided in air ducts at penetration through the compartment wall and floors, see Cl.7.1.2.