



CHAPTER 2

2.1 GENERAL

2.1.1 MEANS OF ESCAPE

The provisions of this chapter of the Code shall serve to express the intentions for determining the design, construction, protection, location, arrangement and maintenance of exit facilities to provide safe means of escape for occupants from all buildings hereafter erected, altered or changed in occupancy. Areas which are designated as means of escape, such as exit staircase, firefighting lobby, smoke stop lobby, exit passageway, escape corridors shall not be turned into other usage.

EXPLANATIONS & ILLUSTRATIONS

Areas which are designated as means of escape, such as exit staircase, firefighting lobby, smoke stop lobby, exit passageway, escape corridors shall not be turned into other usage. The general statement is intended to remind Qualified Person, building owner, Fire Safety Manager on the sole use of the designated lobby as there were cases of designated lobby being converted to commercial areas.

The above exemption, however, does not mean that the QPs (Architects) need not comply with the relevant fire safety requirements in the Fire Code. The QPs are to self-regulate and to ensure that:

- (i) the buildings are designed with proper means of escape;*
- (ii) walls, floors are constructed of non-combustible materials;*
- (iii) the separating walls between units are properly constructed to prevent fire spread etc.*

Similarly, owners when carrying out internal renovation to their houses should also observe and comply with fire safety requirements in the Fire Code, for example, avoid introducing combustible partitions.

**EXPLANATIONS & ILLUSTRATIONS****2.1.1**

The provision of fire escape in buildings under Purpose Groups II to VIII comprises 3 distinct parts;

- (a) The part within the functional room spaces to the exit staircase/area of refuge;*
- (b) The exit staircase; and*
- (c) The exit discharge.*

*(a) **The part within the functional room spaces to the exit staircase/area of refuge.***

It is critical that occupants from their respective areas of occupancy are able to get out within a prescribed distance, should a fire break out. The prescribed distances (given in Table 2.2A) shall be measured from the most remote point in that room space to its entrance (on first storey), or to the nearest exit staircase door, serving that storey or to door of area of refuge.

Occupants in room spaces, provided with two or more exit doors, should ensure that all these doors are readily opened for escape in emergency situations.

*(b) **The exit staircase***

Once the occupants have entered the exit staircase, they shall be protected (from exposure to fire risk and obstacle) throughout their descent down the staircase to the final exit at ground level.

*(c) **The exit discharge***

Occupants exiting from the exit staircases shall be able to discharge into the open external space at the ground level. From this point on they should no longer be in any danger from the fire or smoke in the building.

Where an exit opens or discharges into an internal courtyard, a safe passageway must be readily available to lead the occupants out from this internal courtyard to safety at the building exterior.

Examples on the detailed workings in deriving the total number of and widths of exit doorways and staircases, applying the above steps are furnished herewith as Attachment 1 which can be found at the end of the chapter.

*(d) **The part outside the unit***

In the case of Purpose Group II building, there is another critical consideration and that is the part “outside the residential unit”.

Staircase Identification

Every staircase must be given a means of identifying it, irrespective of the height of the building.

Staircase identification is to facilitate firefighting operation. It also enables the user of the staircase to orientate his location or whereabouts. This would help to alleviate any fear of disorientation by a person using the staircase during a fire emergency.

EXPLANATIONS & ILLUSTRATIONS

2.1.1

A fire escape plan is for use by the public and occupants in case of a fire as well as for the fire fighters. A good fire escape plan should therefore be clearly visible, with legible lettering and the fire escape route made clear to the readers. It should clearly show the layout of the floor in the correct building orientation and highlight the escape routes (in relation to viewer's location), escape corridors and exit staircases using appropriate colours, directional signs and words. Other information required on the plan is for fire-fighting purposes and these include the following;

- (1) Firemen's lift
- (2) Hose reels
- (3) Extinguishers
- (4) Dry and wet risers
- (5) Fire indicator board
- (6) Manual alarm call points

These plans should be placed at common area locations in such buildings where the public and occupants of the building are most likely to frequent or use. Such locations can include the common corridors, lobbies/lift lobbies (if available) and staircases. These plans should be placed at locations such that the general public can locate them immediately when moving through these common areas.

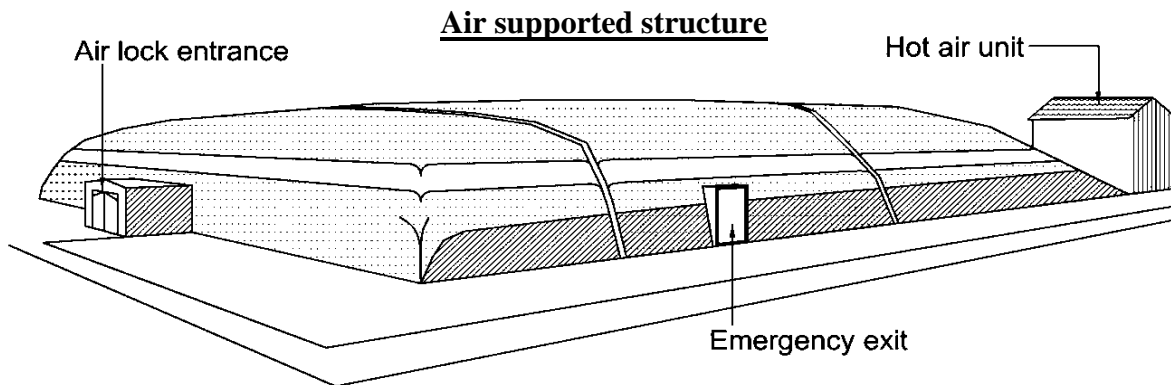

Diagram 2.1.1

- (a) There are various types of air supported or pneumatic building. Air supported structures are used for commercial and industrial applications, such as dining area, warehousing and manufacturing processes, for the agricultural and horticultural industries etc.
- (b) The membranes used for the air supported structures are usually nylon, plastic, PVC or polythene sheet material, which are combustible in a fire.
- (c) The main concerns are:
 - (i) the likelihood of the collapse of the roof owing to lack of pressure inside the structure or during times of emergency;
 - (ii) the combustibility of the structure itself; and
 - (iii) the collapse of the roof may cause panic and difficulties to occupants escaping during times of emergency.
- (d) In view of the above, proposal for air supported structure shall be evaluated separately and the MFRS's consent shall be obtained before making building plan submission.



CHAPTER 2

2.2 DETERMINATION OF EXIT REQUIREMENTS

2.2.1 General

The determination of exit requirements for a building shall be based upon the type of use or occupancy of the building, the occupant load, the floor area, the travel distance to an exit and the capacity of exits as provided in Table 2.2A and herein. Every storey of a building shall be provided with exit facilities for its occupant load. Vertical exits provided from any storey above ground level may serve simultaneously all storeys above the ground level and vertical exits provided from any storey below ground level may serve all storeys below ground level, subject to the provisions of Cl.2.3.5 which prohibit basement staircases being continuous with exit staircases serving the upper storeys, unless otherwise allowed by the MFRS.

EXPLANATIONS & ILLUSTRATIONS

According to Table 2.2A, detached, semi-detached, terraced houses and linked-houses such as townhouses not exceeding 3 storeys, including basement or attic, need not comply with requirements relating to travel distances, exit capacity. However, the width of the staircase that would be used for escape in times of emergency shall not be less than 900mm; all corridors that link the staircase shall not be less than 1200mm.

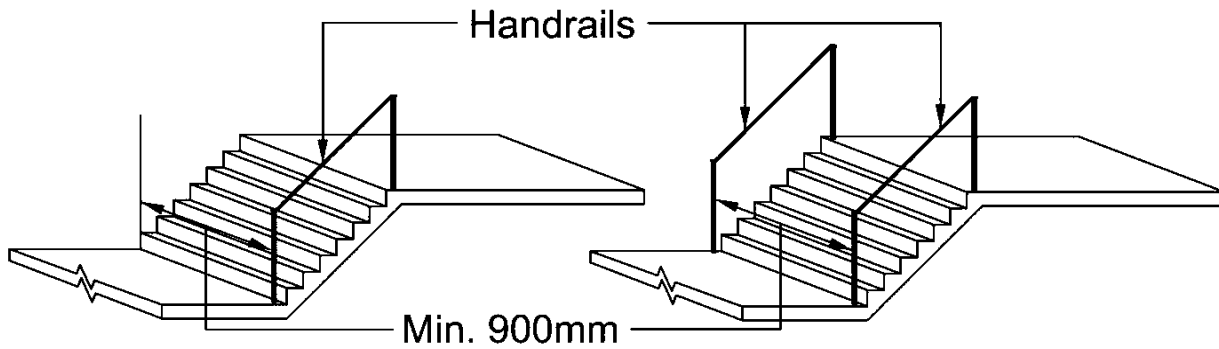

Diagram 2.2.1

The projection of handrail on each side of a staircase shall not exceed 80mm

**EXPLANATIONS & ILLUSTRATIONS****2.2.1**

The process on how to determine the number of and adequacy of exit facilities from a given space or a storey of a building will be explained herewith. Schedules 2 to 8 in Chapter 1 and Table 2.2A as given in the Fire Code will be referred to.

The Cl.2.3.5 referred here covers requirements pertaining to the non-continuity, or separation, of exit staircases serving upper storeys from that serving the basement storeys of a building. Its details and the conditions for exemptions, if any, will be illustrated under the Cl.2.3.5.

Determining number and adequacy of exit facilities

It is very essential that the building designers establish the number, sizes and capacity of exit facilities, especially that of exit doorways and exit staircases, to ensure their adequacy in facilitating the evacuation of all the occupants from that building during an emergency,

To determine the number and adequacy of exit doorways and staircases from a building or storey of a building, the following 3 steps must be taken:

- (1) Determine the occupant load, OL, on each storey of the building. This means computing the total number of persons that could be 'accommodated' in all spaces on a storey of the building. This is done on a storey by storey basis.*
- (2) Determine the number of 'unit of width' of exit required facilitating escape for the above OL from each storey of that building. Clause 2.2.5 shall be referred for the explanation and application of the 'unit of width' for exit computation.*
- (3) Determine the number of and the minimum widths of the exit doors and exit staircases required facilitating escape for that OL on each storey of that building.*



CHAPTER 2

2.2 DETERMINATION OF EXIT REQUIREMENTS

2.2.2 Mixed Occupancy

Where different parts of a building or storey of a building are designed for different types of occupancies or used for different purposes at the same time, the exit requirements of the entire building or storey of the building shall be determined on the basis of that type of occupancy or usage having the strictest exit requirements or the exit requirements for each building section shall be determined separately.

EXPLANATIONS & ILLUSTRATIONS

1) Travel distance requirement:-

For a storey of mixed occupancy building consisting of offices, factories and warehouses, the exit capacity of staircases may be based on the total of the occupancies computed separately for each usage type as per schedules 4, 6 and 8. However the position of the exit staircases shall be so located that the maximum permissible travel distance from any remote point to the staircase shall be based on that of the factory, having the stricter requirements in Table 2.2A. That is, equal to 30m for two-way non-sprinkler protected buildings and 60m for two-way sprinkler protected buildings, and not the 45m and 75m distances allowable for office developments. Hence:

Travel distance (in diagram 2.2.2-1) to the nearest exit staircase shall not exceed 30m or 60m (if sprinkler protected).

The Direct distance to the nearest exit staircase, if there are no predetermined walls, shall not exceed 20m ($\frac{2}{3} \times 30m$) or 40m ($\frac{2}{3} \times 60m$, if sprinkler protected).

Example of a mixed development with factory, office and storage

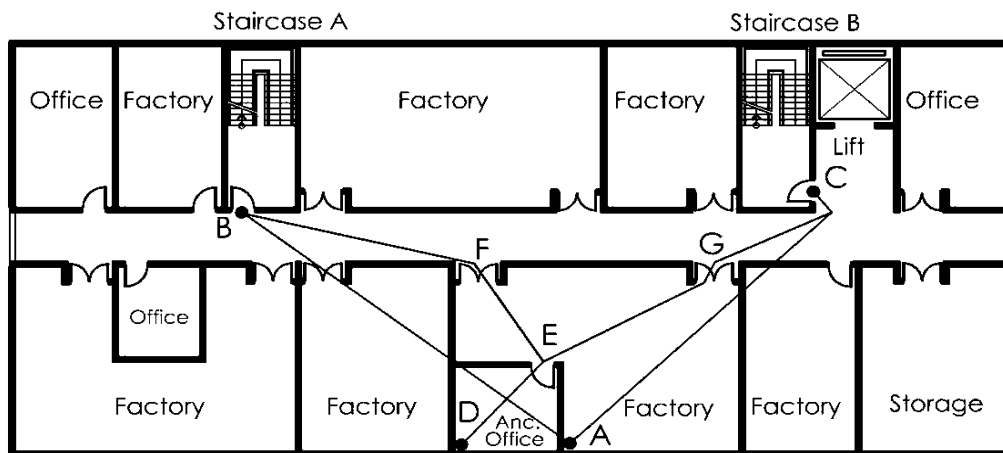

AB and AC are Direct Distance measurements annotated by
DEFB and DEGC are Travel Distance measurement paths annotated by

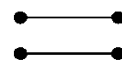

Diagram 2.2.2-1

EXPLANATIONS & ILLUSTRATIONS

2.2.2

The exit provisions in a mixed development may be assessed and provided separately if the differing purpose types are clearly defined and compartmentalized. For example, the escape distances for the offices' area which is clearly located in one part of the building as shown in diagram 2.2.2 – 2 may be based on the office configurations given in Table 2.2A. The remaining part of the building with the industrial usage is then based on the factory configurations.

EXAMPLE OF SEPARATE TRAVEL DISTANCE APPLICATION

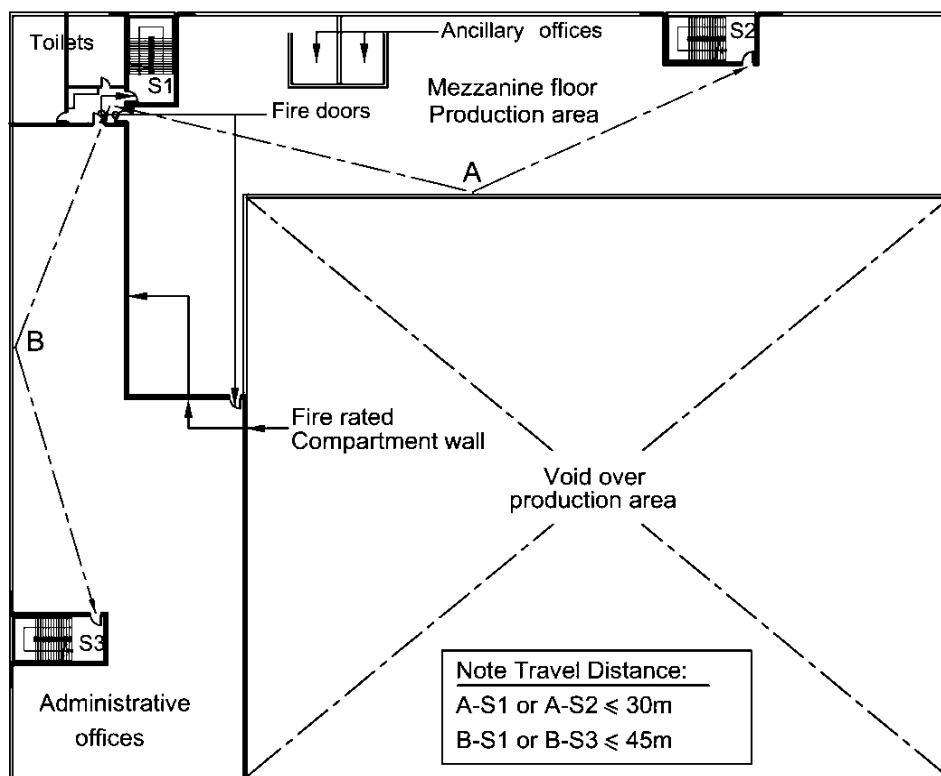

Diagram 2.2.2-2

SECOND STOREY / MEZZANINE FLOOR PLAN

(2) Exit requirement:-

Buildings with mixed occupancies the exit capacity of its exit staircases shall be based on the type of occupancy or usage having the strictest exit requirements given in Table 2.2A.

For example;

A storey of a building comprises dormitory, production and offices separated by usage with compartment walls, but shares common facilities like the staircases.

Then the exit capacity of its staircases shall be based on:

Dormitory occupancy

With regard to exit capacity, the number of persons per unit of exit width (500mm) of staircase shall be 45 persons.

EXPLANATIONS & ILLUSTRATIONS

2.2.2

Instead of:

Factory / Office / Warehouse occupancies

Number of persons per unit of exit width (500mm) of staircase = 60 persons.

**Mixed Factory Development with Office and Dormitory Blocks
Sharing Common Exit Staircases**

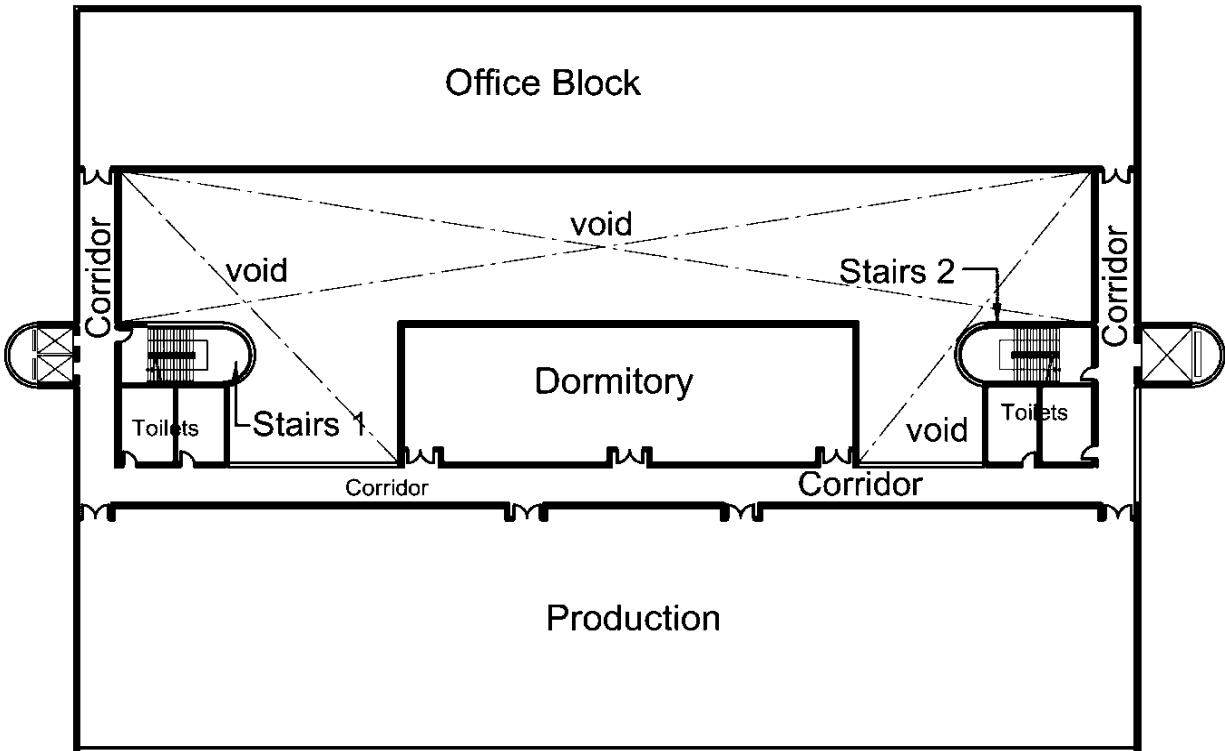

Diagram 2.2.2-3

The maximum permissible occupant load (OL) for the entire storey of the building in diagram 2.2.2-3, for example, shall be based on the capacity of the two exit staircases of 2m width each, assumed serving a dormitory building.

i.e.:

OL = 4 units x 45 persons x 2 staircases = 360 persons (maximum per storey)

EXPLANATIONS & ILLUSTRATIONS

2.2.2

Two situations where the exit capacities of entire staircase on all storeys are accounted similarly

Building with Mixed Occupancy

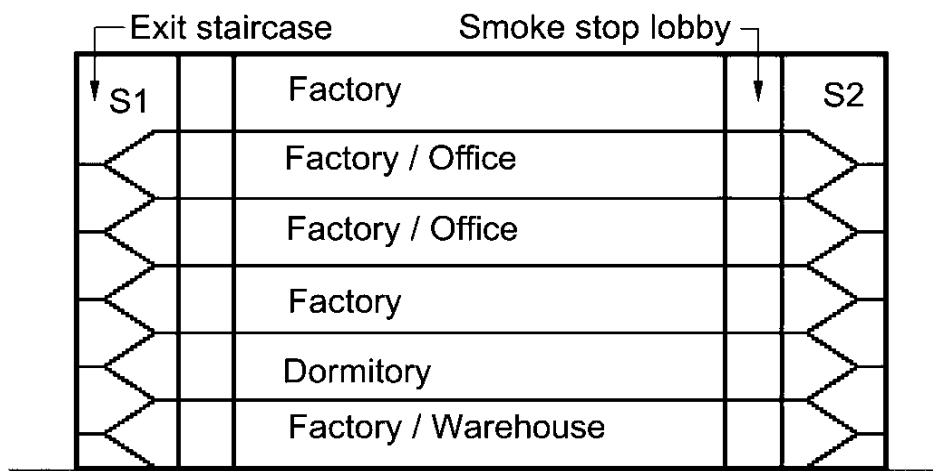

Diagram 2.2.2-4

Building with Mixed Occupancy

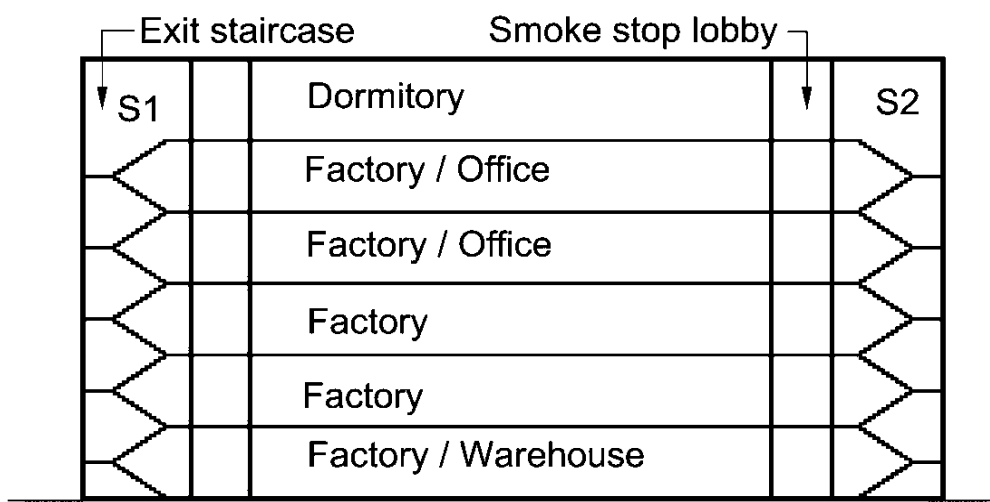

Diagram 2.2.2-5

This capacity of staircase exit width shall be applicable for all levels or storeys of the building with such shared staircase arrangement. This is regardless of the dormitory being located on the second storey or the top most storey of a multi-storey building. The only exemption is when the space with the more stringent requirement per unit of exit width, e.g. the dormitory, is located on only the ground level storey with direct escape to the external space.

EXPLANATIONS & ILLUSTRATIONS

2.2.2

(1) Travel distance requirement:-

For a storey of mixed occupancy building consisting of offices, shops and place of public resort, the exit capacity of staircases may be based on the total of the occupancies computed separately for each usage type as per schedules 4, 5 and 7. However the position of the exit staircases shall be so located that the maximum permissible travel distance from any remote point to the staircase shall be based on that of the shop, having the stricter requirements in Table 2.2A. That is, maximum 45m two-way escape travel distance for non-sprinkler protected buildings and 60m two-way escape travel distance for sprinkler protected buildings shall be applicable and not the 45m and 75m distances allowable for office developments. Hence:

Travel distance (in diagram 2.2.2-1) to the nearest exit staircase shall not exceed 30m or 60m (if sprinkler protected).

The Direct distance to the nearest exit staircase, if there are no predetermined walls, shall not exceed 30m ($\frac{2}{3} \times 45m$) or 40m ($\frac{2}{3} \times 60m$, if sprinkler protected).

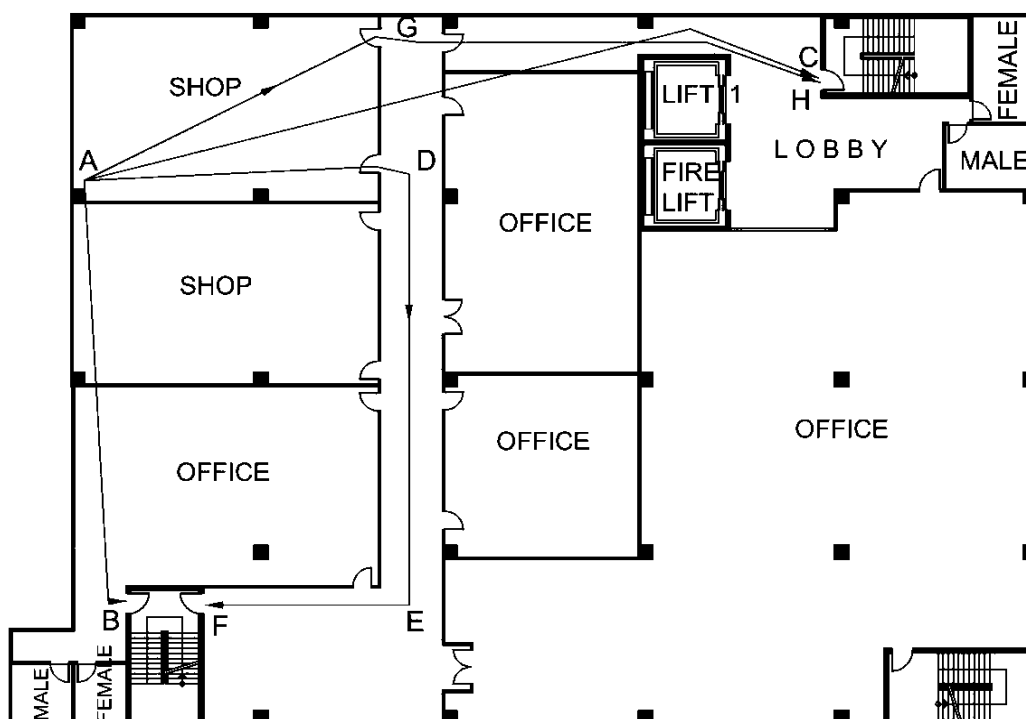

AB and AC are Direct Distance measurement paths annotated by \longleftrightarrow
ADEF and AGH are Travel Distance measurement paths annotated by \dashleftarrow *Diagram 2.2.2-6*

The exit provisions in a mixed development may be assessed and provided separately if the differing purpose types are clearly defined and compartmentalized.

For example, the escape distances for the offices' area, which is clearly located in one part of the building as shown in diagram 2.2.2- 6, may be based on the office configurations given in Table 2.2A. The remaining part of the building with the shopping usage is then based on the shop configurations.

EXPLANATIONS & ILLUSTRATIONS

2.2.2

EXAMPLE OF SEPARATE TRAVEL DISTANCE APPLICATION

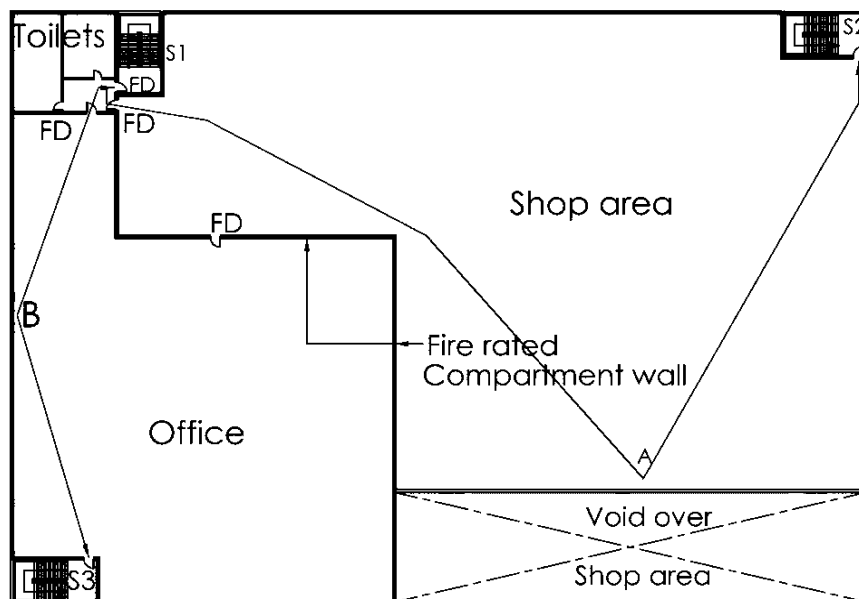

Note Direct Distance:
 A-S1 or A-S2 < 2/3x45m or 2/3x60m (sprinklered)
 B-S1 or B-S3 < 2/3x45m or 2/3x75m (sprinklered)

Diagram 2.2.2 – 7

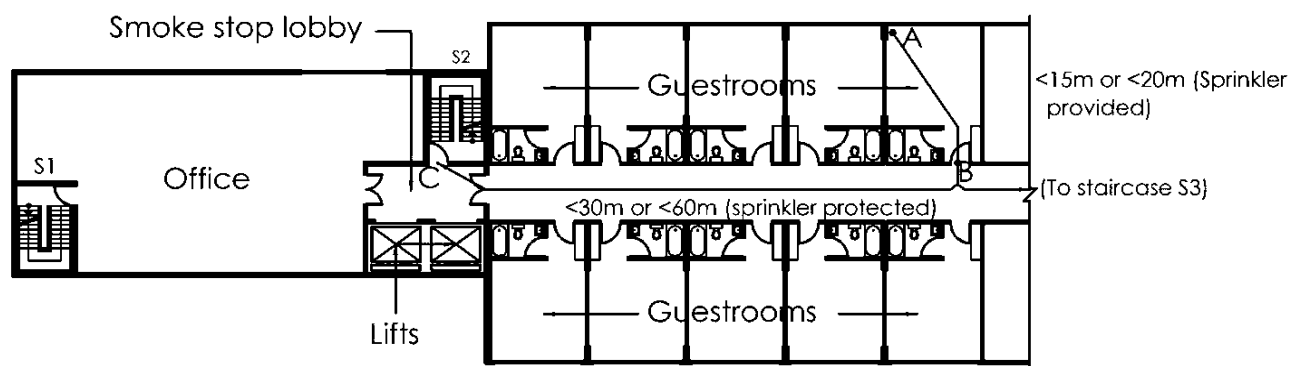

Diagram 2.2.2 – 8

(2) Exit requirement:-

Buildings with mixed occupancies the exit capacity of its exit staircases shall be based on the type of occupancy or usage having the strictest exit requirements given in Table 2.2A.

For example, see diagram 2.2.2-3

EXPLANATIONS & ILLUSTRATIONS

2.2.2

A storey of a building comprises office and hotel residential occupancy separated by compartment walls, but shares common facilities like the staircases and lifts.

Then the exit capacity of its shared staircase (staircase S2) shall be based on the most stringent type of mixed occupancies, i.e. hotel residential floors.

OFFICE OCCUPANCY (STAIRCASE S1)

Number of persons per unit of exit width (500mm) of staircase = 60 persons.

HOTEL RESIDENTIAL OCCUPANCY (STAIRCASE S2 & S3)

Number of persons per unit of exit width (500mm) of staircase = 45 persons.

Mixed Development with Office/Shop And Restaurant Sharing Common Exit Staircases

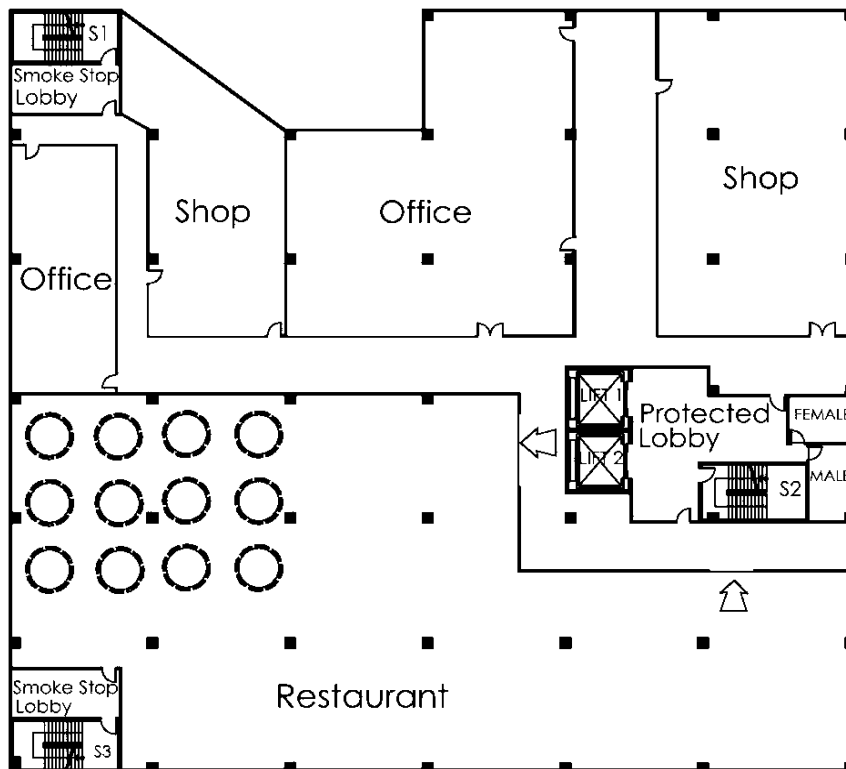

Diagram 2.2.2- 9

The above diagram illustrates a mixed occupancy of office, shop and restaurant sharing common exit staircases (S1 & S2).



EXPLANATIONS & ILLUSTRATIONS

2.2.2

In the case of restaurant, the maximum permissible occupant load can be based on the capacity of the three staircases. As Staircase S3 is for the exclusive use of restaurant, owing to its location, this staircase is inaccessible to occupants from offices and shops. Therefore, Staircase S3 shall not be computed as a common exit staircase rather computed as exit staircase for restaurant only.

i.e.:

$$\begin{aligned}
 \text{Exit capacity of common staircases} &= 4 \text{ units} \times 60 \text{ persons} \times 2 \\
 \text{(Staircases S1 \& S2 of 2m width)} &\quad \text{staircases} \\
 \text{each)} &= 480 \text{ persons}
 \end{aligned}$$

Hence, each common exit staircase can accommodate 240 persons (1/2 of 480 persons)

It is acceptable to allow 1/2 the occupant load of restaurant to use Staircase S3 and the other 1/2 to use the common exit staircases S1 & S2. Therefore, the maximum permissible occupant load for shops and offices shall include 1/2 the occupant load of restaurant, subject to not exceeding a total of 480 persons.

Situation where the exit capacities of entire staircase on all storeys are accounted similarly

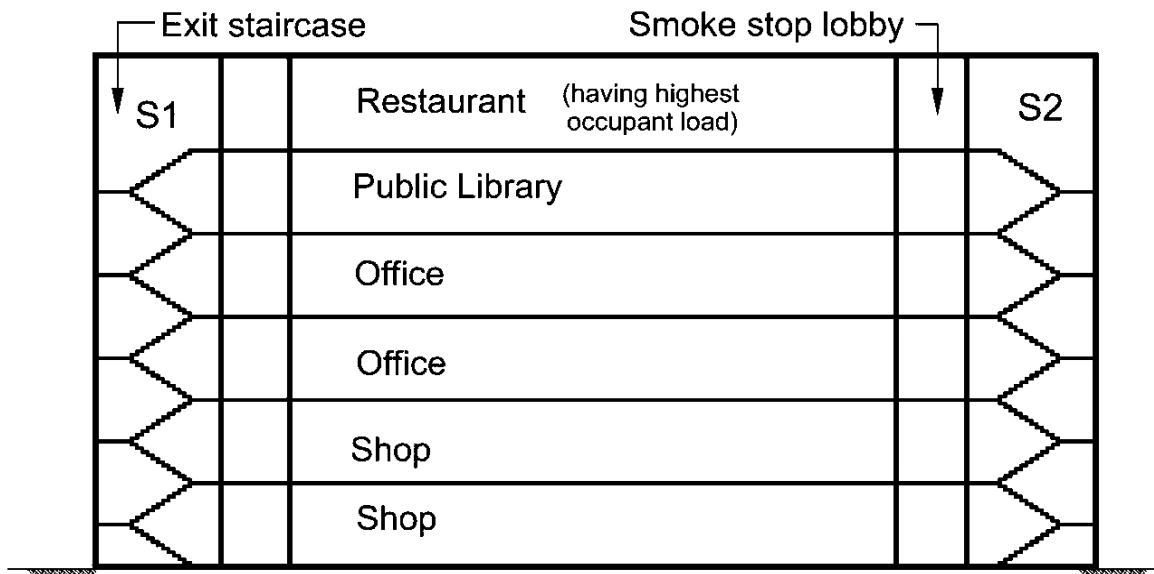

Diagram 2.2.2-10

The strictest capacity of staircase exit width (applicable to restaurant) shall be applicable to all levels or storeys of the building with such shared staircase arrangement. This is regardless of the restaurant being located on the second storey or the top most storey of a multi-storey building.



EXPLANATIONS & ILLUSTRATIONS

2.2.2

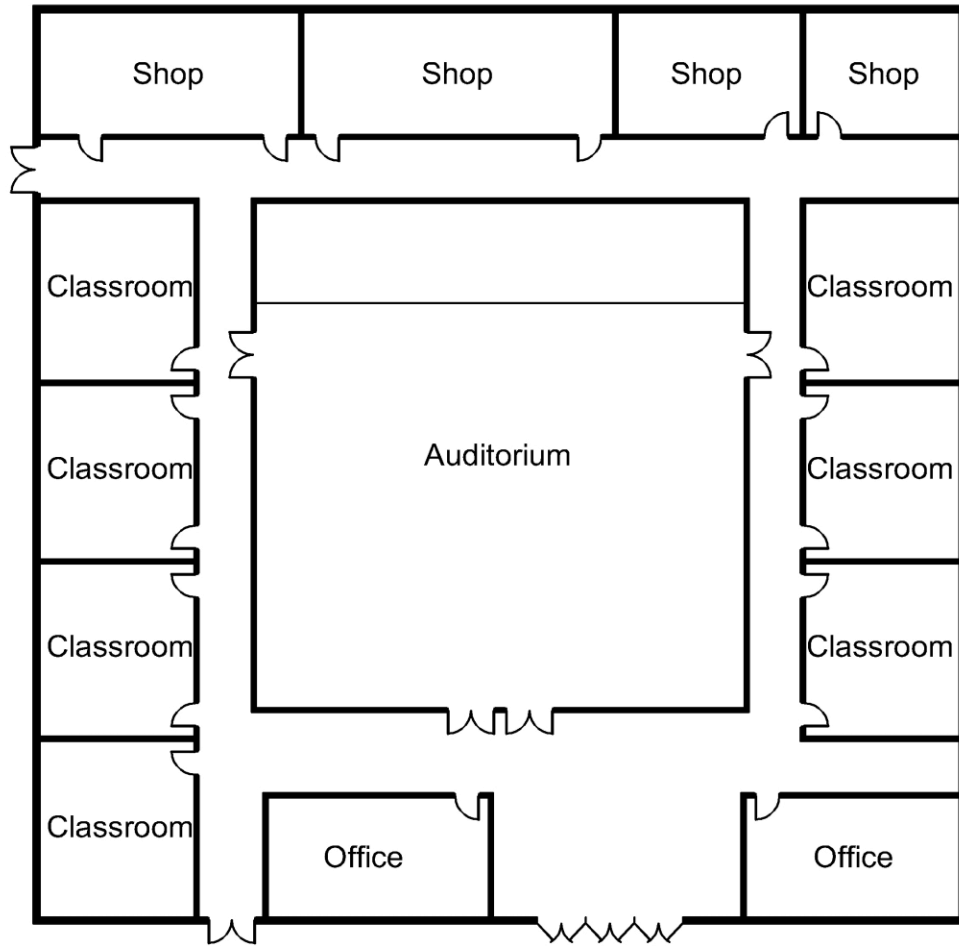

Diagram 2.2.2-11

Mixed occupancy building

Auditorium space shares the internal corridor as the classrooms. Such space cannot be qualified as non-simultaneous occupancy within the same storey.



CHAPTER 2

2.2 DETERMINATION OF EXIT REQUIREMENTS

2.2.3 Multiple occupancy or use

Where a building or storey of a building or a part of a building is used for multiple purposes involving different activities at different times, that purpose or use involving the greatest number of occupants shall form the basis for determining the exit requirements.

EXPLANATIONS & ILLUSTRATIONS

A Multi-purpose Hall is an example of a space with multiple occupancy or use. It may have the various uses as listed below. Its exit provisions shall be based on the usage with the greatest occupant load. In this case it should cater to that of the dance hall, being the most stringent basing on an area of 1m² per person.

Examples of usage of multipurpose hall:-

- Sports gym
- Dinner / buffet functions
- Exhibitions / seminars
- Church assembly
- Lecture hall / classroom
- Dance hall

Example of building with a multiple usage storey

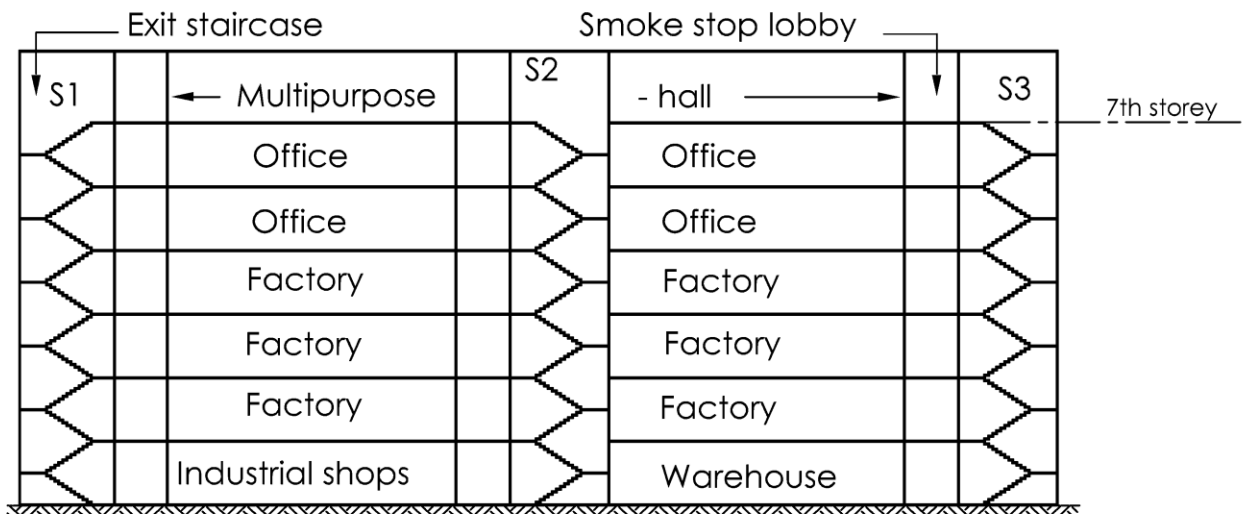

Diagram 2.2.3-1



EXPLANATIONS & ILLUSTRATIONS

2.2.3

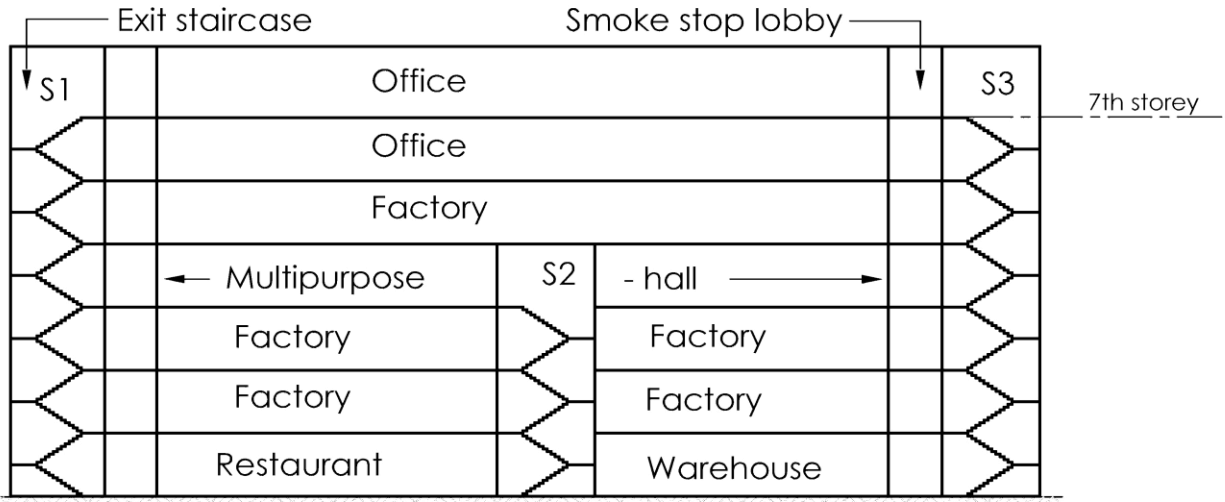

Diagram 2.2.3-2

In diagram 2.2.3-1, the multi-purpose hall located on the 7th storey would have the highest occupant load. Hence, adequate number of exit staircases required to accommodate the evacuation of its occupant load shall be provided to the building. The total exit capacity of its exit staircases shall be determined based on its usage with the highest density of people. The exit staircases shall be carried right down to the ground level without any reduction in its width, regardless of the lower storeys having lesser number of occupants.

On the other hand, if the multi-purpose hall is located on an intermediate storey, then the exit requirements or provisions from that storey shall only be applicable to all the storeys below it. As for those storeys above that storey with the multipurpose hall, their exit capacities need only cater to what is the strictest above each respective storey.



CHAPTER 2

2.2 DETERMINATION OF EXIT REQUIREMENTS

2.2.4 Non-simultaneous occupancy

The floor areas of toilets, locker rooms, storage rooms, lobbies, corridors and similar rooms and spaces that serve other rooms and spaces on the same storey but are not occupied at the same time as such other rooms or spaces, may be omitted from the occupant load calculations of that storey of the building on which they are located.

EXPLANATIONS & ILLUSTRATIONS

Communal roof deck which is accessible to all residents shall be treated separately for the calculation of occupant load. For buildings under purpose group II, the occupancy load calculation is based on gross floor area of 15 sq. m per person, calculated on habitable areas. Spaces outside the residential units, such as lobbies, corridors would be excluded from calculation. Similarly, within the residential units, areas, such as toilets, store room, kitchen and household shelter would be excluded from calculation. Living room, balconies and bedroom should be treated as habitable areas.

Examples of Non-simultaneous areas

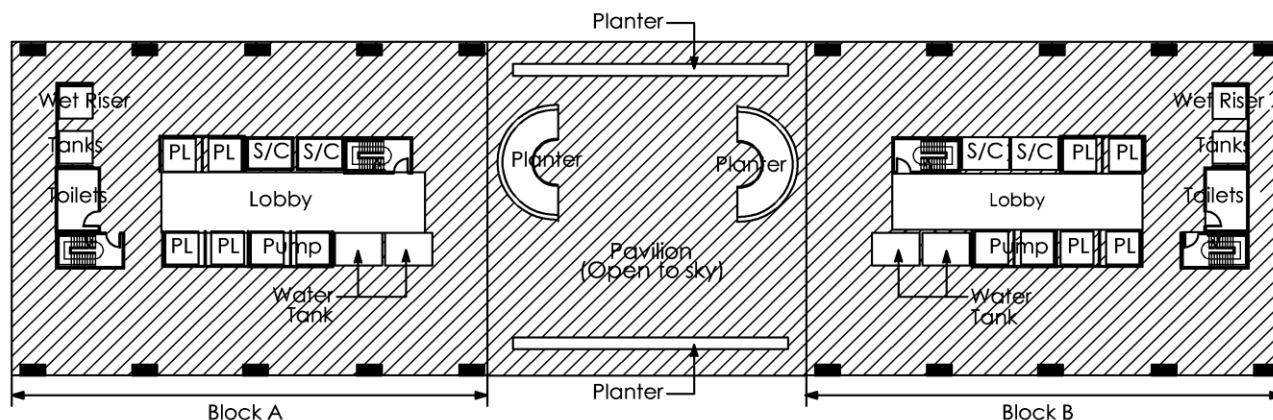

20th storey



The communal floor space intended for non-residential use shall be subjected to occupant load calculation.

Diagram 2.2.4

EXPLANATIONS & ILLUSTRATIONS

2.2.4

It is to be noted here that the staff canteens, though inadvertently included in this clause, is to be treated as simultaneous occupancies as reflected in the schedules. This is due to the nature of its usage, whereby public or staff from other levels of the building would be patronising it through its operating hours. Pantries on the other hand, provided in the various levels of offices or production areas, catering to specific group of staff, may be treated as non-simultaneous areas. Hence, in applying the above clause, building owners has to be certain such rooms or spaces are not accessible to the public.

Examples of Non-simultaneous areas (exaggerated)

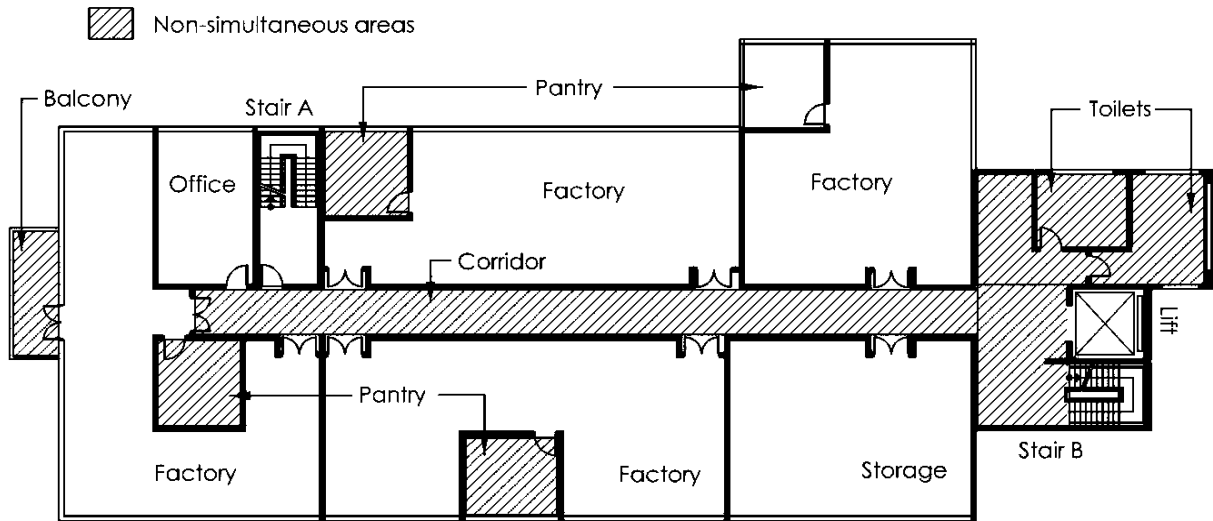
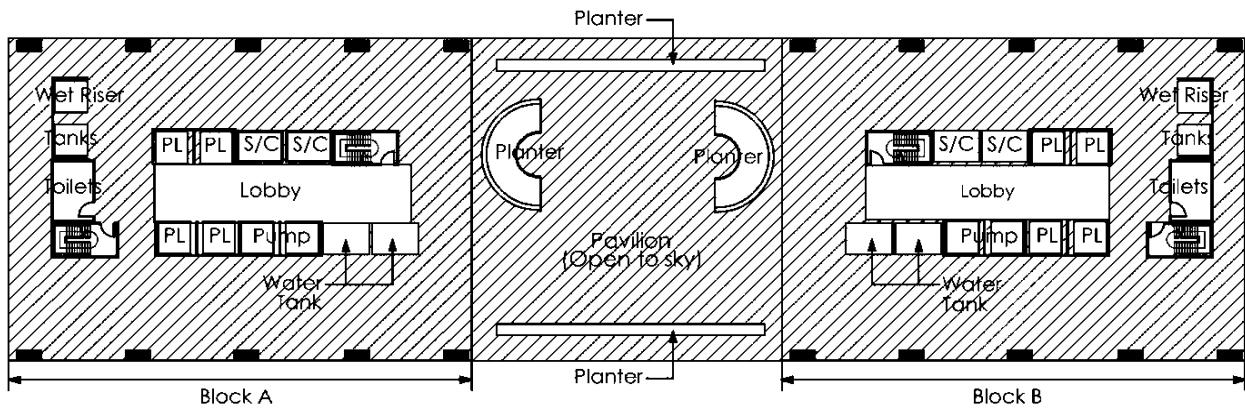

Diagram 2.2.4-1

Examples of Non-simultaneous areas



20th storey

The communal floor space intended for non-residential use shall be subjected to occupant load calculation.

Diagram 2.2.4-2

Diagram 2.2.4-1&2 shows examples of areas that can be treated as non-simultaneous areas and be exempted from computation of the occupant load for that storey of the building.



CHAPTER 2

2.2 DETERMINATION OF EXIT REQUIREMENTS

2.2.5 Capacity of exits and exit facilities

The capacity of exits, exit staircases, exit passageways, corridors, exit doors and other exit facilities shall be measured in units of width of half of a metre. The number of persons per unit of width shall be determined by the type of occupancy and type of exit as listed under Table 2.2A. In the determination of each exit width, fractions of a unit width less than 250mm shall not be credited. Where 250mm or more are added to one or more full units, half of a unit of width shall be credited.

Where a room or space is required to be provided with two exits, each exit shall be of sufficient width to accommodate not less than half the total occupant load.

EXPLANATIONS & ILLUSTRATIONS

To prevent overcrowding one has to ensure that the corridor and the exit staircases serving a storey of a building are adequate in size to receive all the occupants on that floor at the time of evacuation.

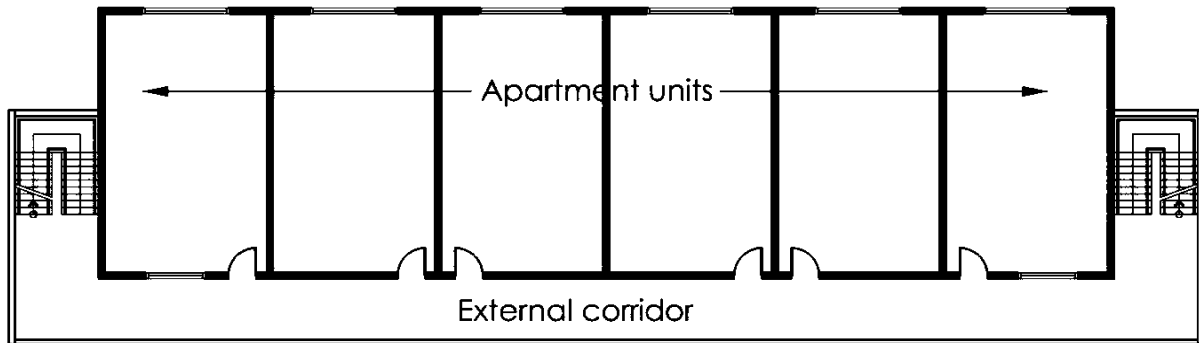

Plan — Typical floor plan of standard slab design

Diagram 2.2.5-1



EXPLANATIONS & ILLUSTRATIONS

2.2.5

The capacity of exit doors to the industrial units, corridor, exit doors to staircases and exit staircases are measured in units of width of one half of a metre i.e.:

<i>Clear width of exit door/corridor/staircase</i>	<i>Number of unit widths</i>
<i>1m</i>	<i>2</i>
<i>1.5m</i>	<i>3</i>
<i>2m</i>	<i>4</i>

Where a fraction of 250mm or more are added to one or more full units, half of a unit of width shall be credited, for example:

<i>Clear width of exit door/corridor/staircase</i>	<i>Number of unit widths</i>
<i>1000 to 1249</i>	<i>2</i>
<i>1250 to 1499</i>	<i>2.5</i>
<i>1500 to 1749</i>	<i>3</i>
<i>1750 to 1999</i>	<i>3.5</i>
<i>2000 (maximum)</i>	<i>4 (maximum number per exit)</i>

The number of persons per unit of width shall be determined by the type of occupancy and type of exit as listed under Table 2.2A of the current Fire Code.

Example 1;

High hazard building:

1 unit width = 500mm = 30 and 40 persons per unit width through staircase and doorway respectively.

Therefore:

1m doorway facilitates escape for 80 occupants from a high hazard factory, while 1m of its stairway permits escape for only 60 of its occupants.

The high hazard building has very much more stringent requirements than other buildings. It is due to the nature of its contents. In an emergency situation, because of the highly volatile or explosive nature of the contents, its occupants have very little reaction time to evacuate to a safer area. Hence, exits must be designed such that they are more readily available for escape purposes.

Where a room or space is required to be provided with two exits, each exit shall be of sufficient width to accommodate not less than one half the total occupant load.

EXPLANATIONS & ILLUSTRATIONS

2.2.5

Acceptable distribution of Exit capacity

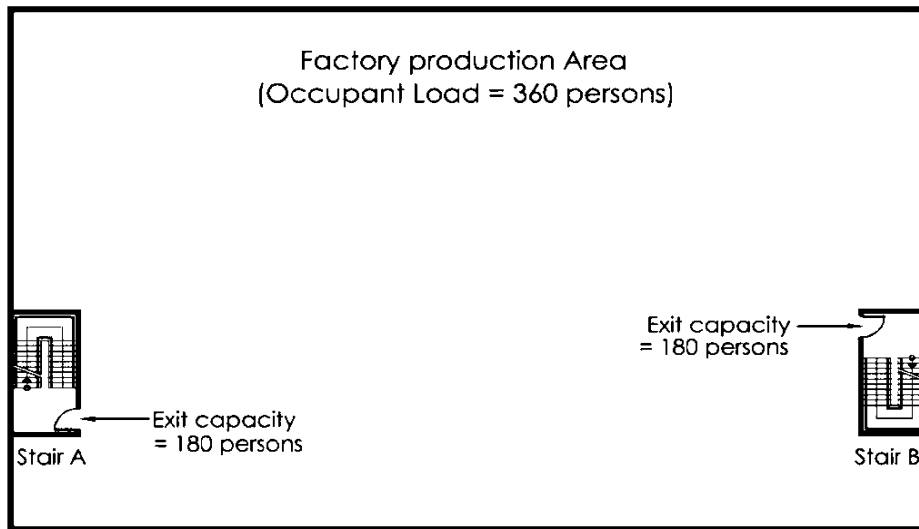

Not Acceptable distribution of Exit capacity

Diagram 2.2.5-2

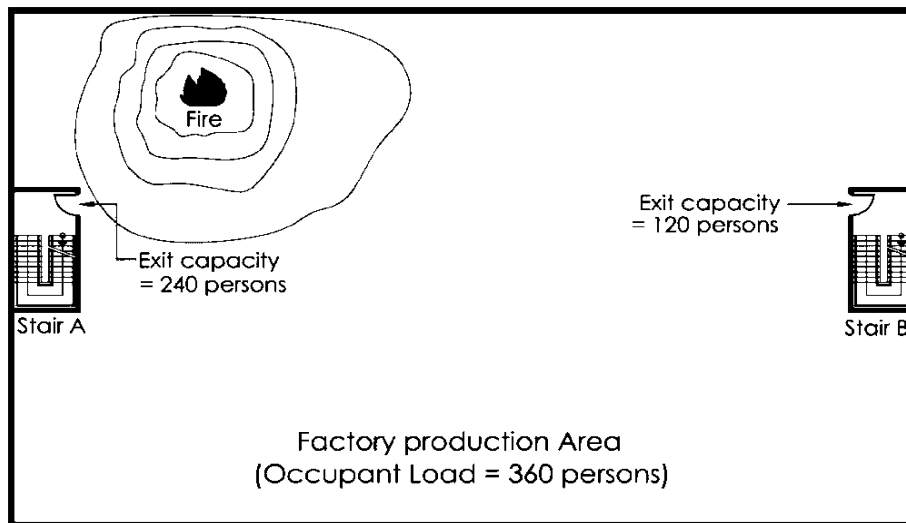

Diagram 2.2.5-3

The above sub-clause is to address the problem, which may arise if staircases are not proportionately sized and distributed. For example, a fire near Stair A in diagram 2.2.5 –3, which is designed to facilitate escape for 240 persons, can render it inaccessible. This would mean that, the other exit, stair B, which is only designed for 120 persons’ escape, would hence need to facilitate escape for the full OL of 360 persons from that storey.

This scenario would render stair B to be drastically inadequate to facilitate all the occupants’ timely escape, before the fire and smoke engulf the entire floor space. This is because it would require three times as long to evacuate the occupants from that storey using only stair B.

Imagine the consequences, for a scenario where the entire staircase A with the larger exit capacity is totally damaged or not useable in a high-rise building fire.

CHAPTER 2

2.2 DETERMINATION OF EXTI REQUIREMENTS

2.2.6 Determination of travel distance

The maximum travel distance for the respective types of occupancies shall be not greater than as laid down in Table 2.2A read in conjunction with the following:

- (a) In the case of a floor area designed with minimum two exits, the maximum travel distance as given in Table 2.2A shall be applicable. The maximum travel distance starting from the most remote point in any occupied space to the nearest exit, shall not exceed the limits specified in Table 2.2A, and

EXPLANATIONS & ILLUSTRATIONS

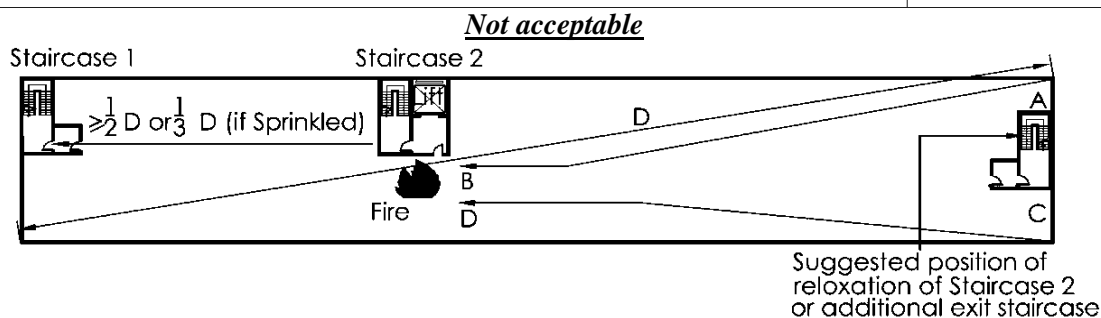

Diagram 2.2.6(a)-1

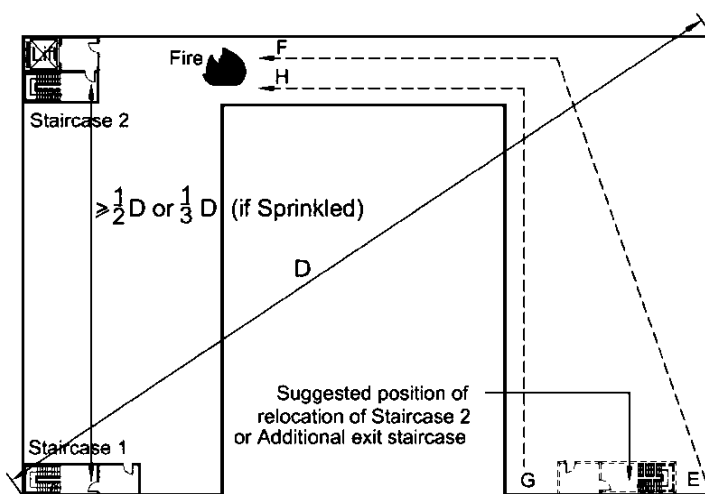

Diagram 2.2.6(a)-2

In the above diagrams, the exit staircases are not remotely located from each other to reduce the possibility that more than one staircase can be blocked off by fire or other emergency condition. The escape routes AB, CD, EF, and GH are all considered as one-way direct travel as there is no alternative escape route. Occupants escaping in a fire emergency are unable to reach the nearest staircase as the escape routes are blocked by fire. The distribution of the staircases does not meet the intents of CL.1.2.60 of current Fire Code, which require that “such exits shall be remotely located from each other and shall be arranged and constructed to minimise the possibility that more than one can be blocked by any fire or other emergency condition”.

In the above diagrams, direct travel distances, which are highlighted, will be considered as one-way direct travel instead of two-way direct distance travel. To overcome the problems of one-way direct travel, relocation or addition of an exit staircase would be necessary, subject to meeting the direct travel distance requirements.

(b) In a large floor area sub-divided into rooms, corridors and so forth, the travel distance requirements of the foregoing paragraphs of this clause shall be deemed to be satisfied if the 'direct distance' does not exceed two-third of the maximum travel distance permitted under Table 2.2A, and

EXPLANATIONS & ILLUSTRATIONS

2.2.6

Similarly, if the details of the internal layout are furnished on the building plan submissions, hence the actual travel distances permissible under the Table 2.2A would be taken into account.

However, in most situations during the planning and building plan submission stages of a building, its designer is unable to confirm the layout of the storey spaces. It is therefore recommended that the direct distance measurements, which are two thirds of the allowable travel distances, be strictly applied to such 'open' plans.

Example

Typical single tenancy single office storey

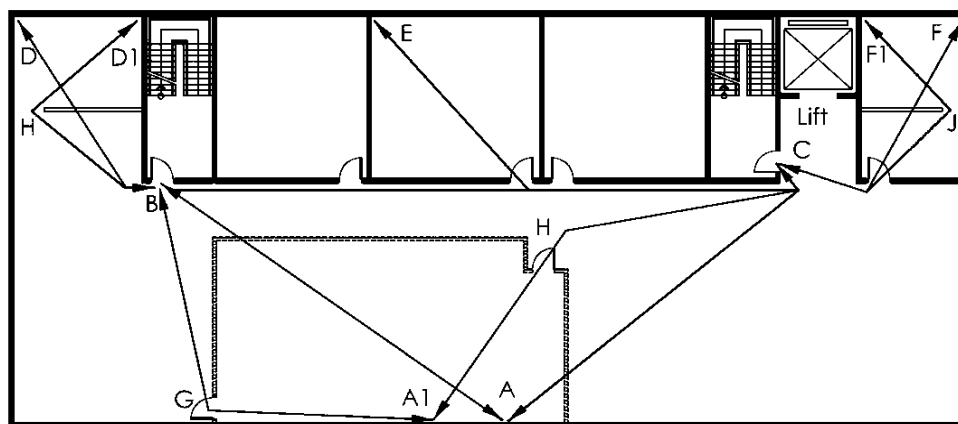

AB and AC are Two-way Direct Distance measurement paths annotated by \longleftrightarrow

DB and FC are One-way Direct Distance measurement path annotated by \longleftrightarrow

Undetermined future partitioning probability -----

Diagram 2.2.6(b)-1

The dotted walls in diagram 2.2.6(b)-1, for example, may not be shown on plan and/or may be of differing configurations. In such indefinite situation, a straight line drawn from the most remote point A to B or C shall be taken as the two-way direct distance. If the maximum permissible two-way travel distance given in Table 2.2A for such usage is 60m (sprinklered), then the direct distances (straight lines AB or AC) shall not exceed 40m, i.e. $\frac{2}{3} \times 60\text{m}$. This shall also apply to the one-way distances BD and CF, as the actual one-way distances could possibly be DIHB and FIJC.

This application of the direct distance measurements, besides facilitating flexibility for future inclusions and changes in layout, ensures that escape distances for the occupants would not subsequently be excessive and life threatening in a fire emergency.



EXPLANATIONS & ILLUSTRATIONS

2.2.6(b)

(Note: "travel distance" is to be taken as direct Distance).

Maximum escape distance design parameters

	<u>SPRINKLERED</u>			<u>NON -SPRINKLERED</u>		
	<i>Shops</i>	<i>Offices</i>	<i>Places of public resort</i>	<i>Shops</i>	<i>Offices</i>	<i>Places of public resort</i>
<i>One-way Travel Distance (m)</i>	25	30	25	15	15	15
<i>One-way Direct Distance (m)</i>	16.6	20	16.6	10	10	10
<i>Two-way Travel Distance (m)</i>	60	75	60	45	45	45
<i>Two-way Direct Distance (m)</i>	40	50	40	30	30	30

Typical Storey Plan of Office Building

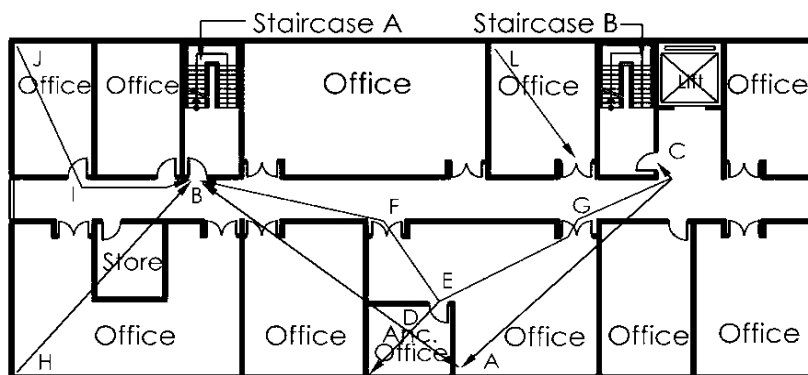

- ←→ AB and AC are Two-way Direct Distance measurement paths annotated by
- ←→ DEFB and DEGC are Two-way Travel Distance
- HB is One-way Direct Distance
- Measurement path annotated by JIB is One-way Travel Distance
- Measurement path annotated by L is one-way Direct Distance [$\frac{2}{3}$ t.d] (internal partitioning of office space is expected)

Diagram 2.2.6(a) & (b)-1

EXPLANATIONS & ILLUSTRATIONS

2.2.6

DIRECT DISTANCE = 2/3 TRAVEL DISTANCE

The actual path that an occupant needs to take from any part of a storey space to the nearest exit door to the external space or exit staircase, will be measured for escape travel distance compliance. This distance takes into account the internal partitions within that floor space and it shall comply with the relevant travel distances stipulated in Table 2.2A.

Thus, where details of the internal layout are furnished in the building plan submissions, for example Diagram 2.2.6 (a) & (b) –1, the full travel distances permissible under the Table 2.2A would be applied.

However, in most situations during the planning and building plan submission stages of a building, the designer is unable to confirm the internal layout of the storey spaces. It is recommended that the direct distance measurement, which is two thirds of the allowable travel distances, should be applied to such ‘open’ layout plans.

Example

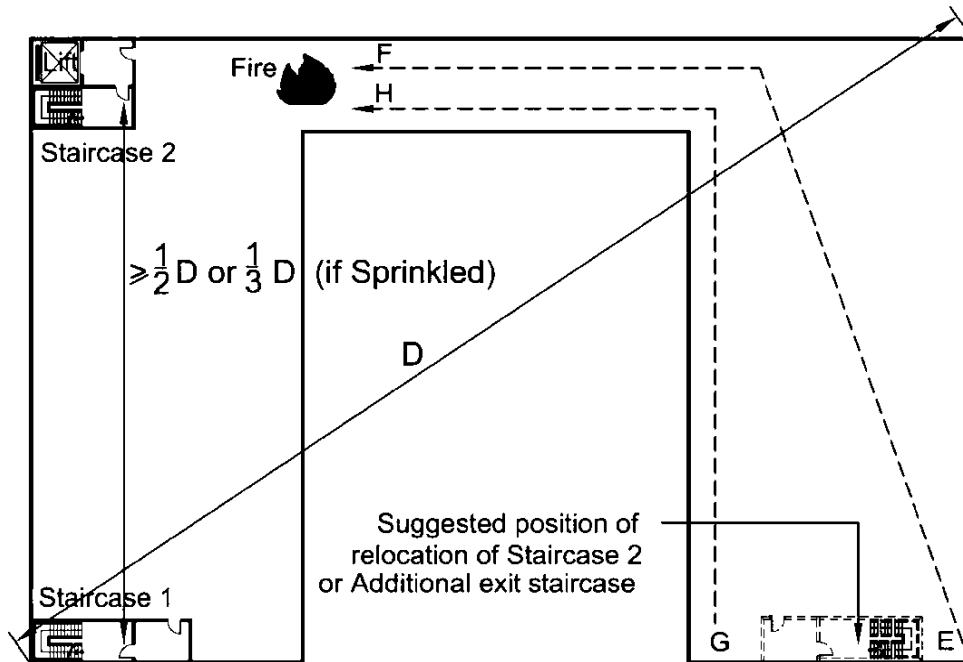

Diagram 2.2.6(a)&(b)-2

EXPLANATIONS & ILLUSTRATIONS

2.2.6

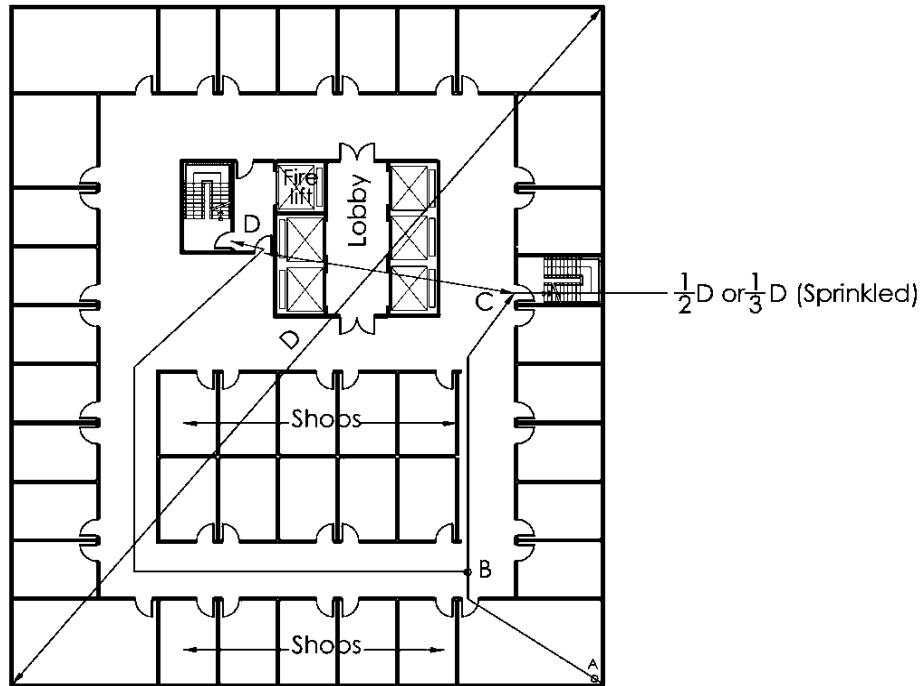

Diagram 2.2.6(a) & (b)-3

A to B is considered as one-way travel distance and it shall be not more than 25m (sprinklered). In computing two-way travel distance, the escape route from point A, B, C shall not exceed 60m (sprinklered).

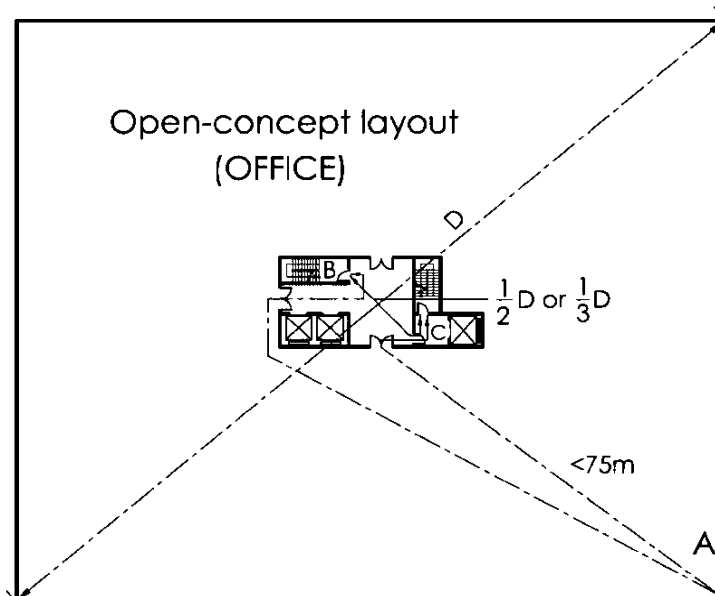

Diagram 2.2.6(a) & (b)-4

Point A to C and Point A to B are considered two-way travel distance if the separation distance between exit doors of the two staircases is equal to or more than $\frac{1}{2}D$ or $\frac{1}{3}D$ (sprinklered). If the storey space is to be subdivided for occupation by more than one occupier, a common corridor around the service core shall be created to meet the travel distance requirements.



EXPLANATIONS & ILLUSTRATIONS

2.2.6

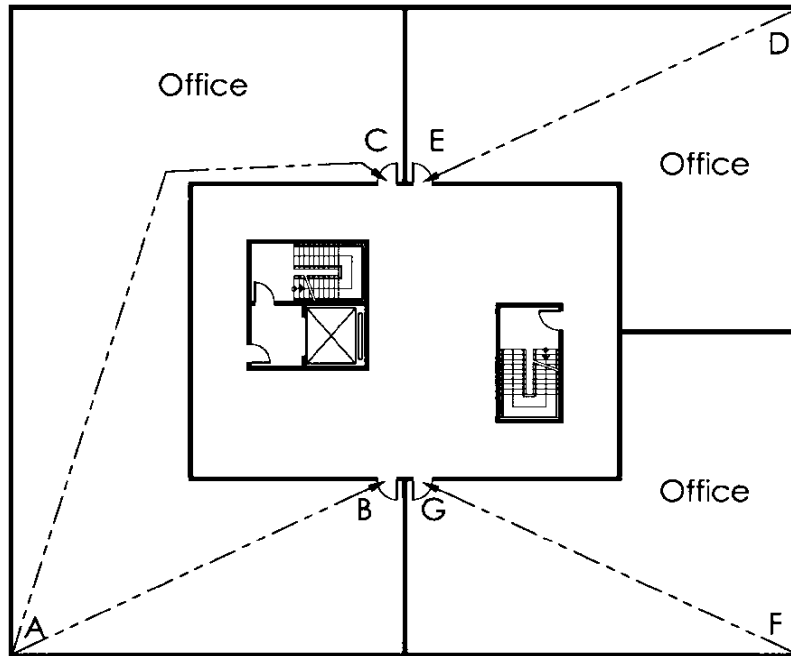

Diagram 2.2.6(a) & (b)-5

Escape routes AB, AC are considered two-way direct travel. Escape routes DE, FG are considered one-way direct travel distances.

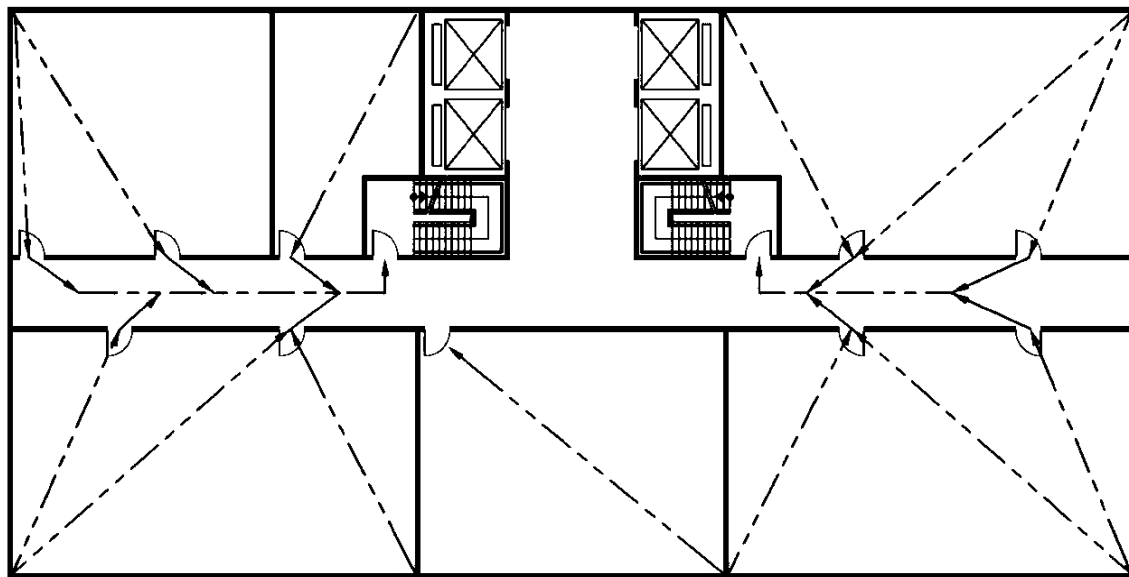

Diagram 2.2.6(a) & (b)-6

The numerous one-way direct travel distances are illustrated by dashed lines.

The provision of fixed corridors and rooms in an open floor space would create numerous “common paths” from the rooms to the exit staircases as shown in the above diagram. Common paths of travel are one-direction travel only without the choice of travelling in another separate direction toward an exit.

EXPLANATIONS & ILLUSTRATIONS

2.2.6

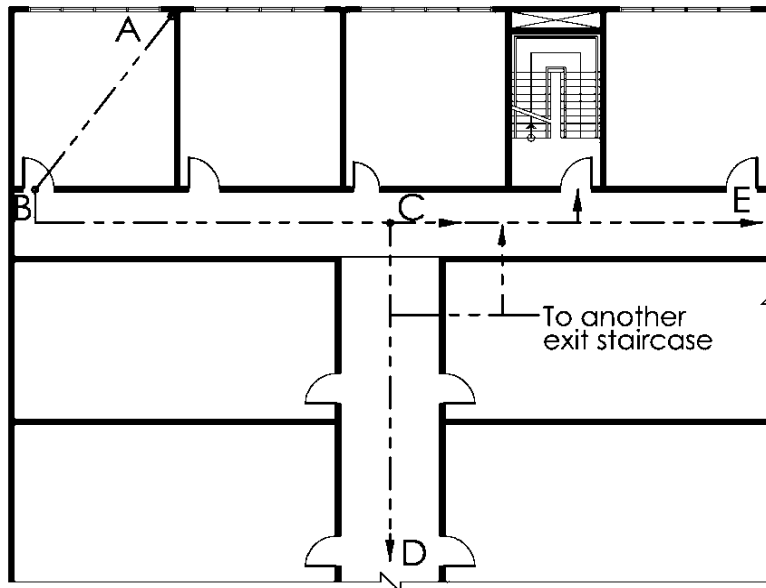

- A - B : One-way travel distance
- B - C : One-way travel distance
- C - E : Two-way travel distance
- C - D : Two-way travel distance

Diagram 2.2.6(a) & (b)-7

In determining the types of travel distance, Point A, B or C is considered one-way travel distance or “common path”. At point C, where an occupant has the choice of more than one escape direction, would be considered as the starting point for 2-way travel distance. Hence, escape routes C E and C D are considered two-way travel distance.

EXPLANATIONS & ILLUSTRATIONS

2.2.6

Some examples of one-way direct and travel distances from subdivision of storey spaces

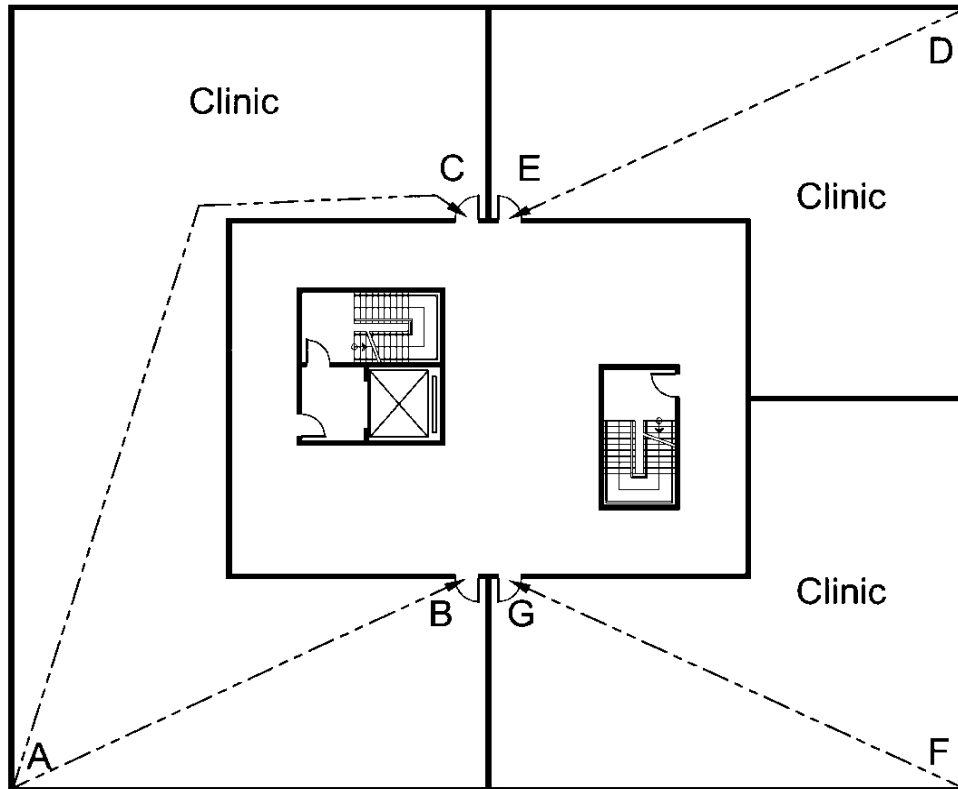

Diagram 2.2.6(a) & (b)-8

Escape routes AB, AC are considered two-way direct travel. Escape routes DE, FG are considered one-way direct travel distances.



(c) For the purpose of this clause, the most remote point from which the travel distance is measured shall be taken as being 400mm from the enclosure walls of the room or space, and

EXPLANATIONS & ILLUSTRATIONS

2.2.6

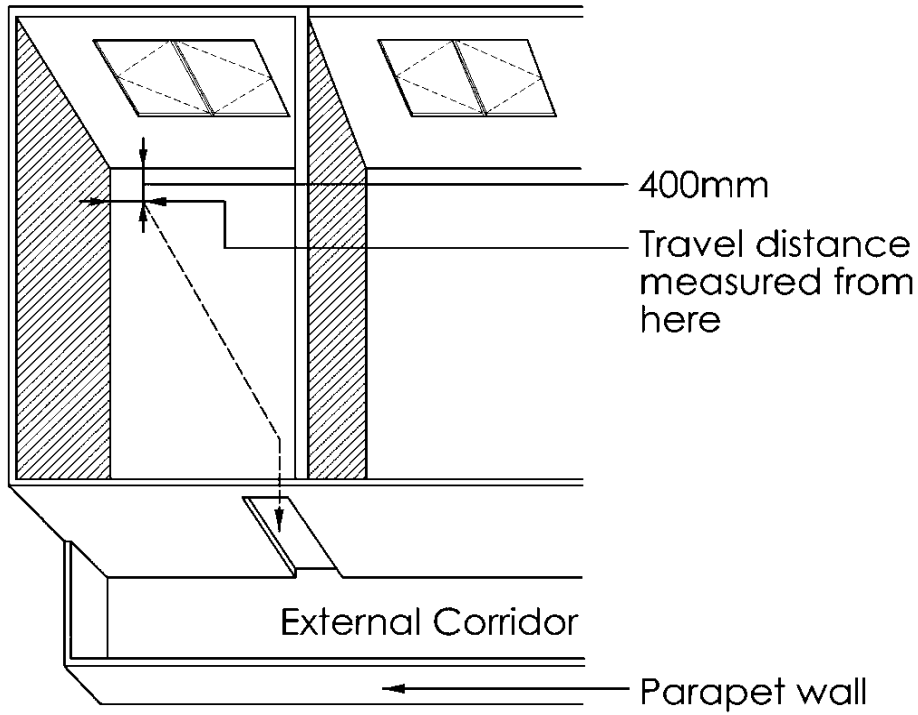

Diagram 2.2.6(c)



(d) In the case of a hotel bedroom, travel distance shall be determined based on the provisions under Cl.2.7.3 for Exit Requirements for Hotels, and

EXPLANATIONS & ILLUSTRATIONS

2.2.6

(No illustration)Please refer to clause 2.7.4



(e) In the case of a residential apartment or maisonette, the travel distance shall be determined based on the provisions under Cl.2.4.7 for Exit Requirements for Residential Occupancy, and

EXPLANATIONS & ILLUSTRATIONS

2.2.6

No illustration.

(f) Where Area of Refuge is provided in lieu of required exits, travel distance shall be measured to the exit door at the corridor leading to the Area of Refuge, and

EXPLANATIONS & ILLUSTRATIONS

2.2.6

Where an area is designated as 'area of refuge' (Building B in diagrams 2.2.6 (f), it must have adequate provision of exit facility and shall be adequate in size to hold the occupant load it receives from the floor area (Building A) it serves, allowing at least 0.3m² per person. Area of refuge acts as a temporary holding area allowing the occupants more time for evacuation. Hence, it shall be protected from the fire and smoke risk from building A via the provision of cross-ventilated bridges or protected external passageways.

Reference shall also be made to Cl.1.2.4 and Cl.2.2.15 for more explanations and details on the area of refuge.

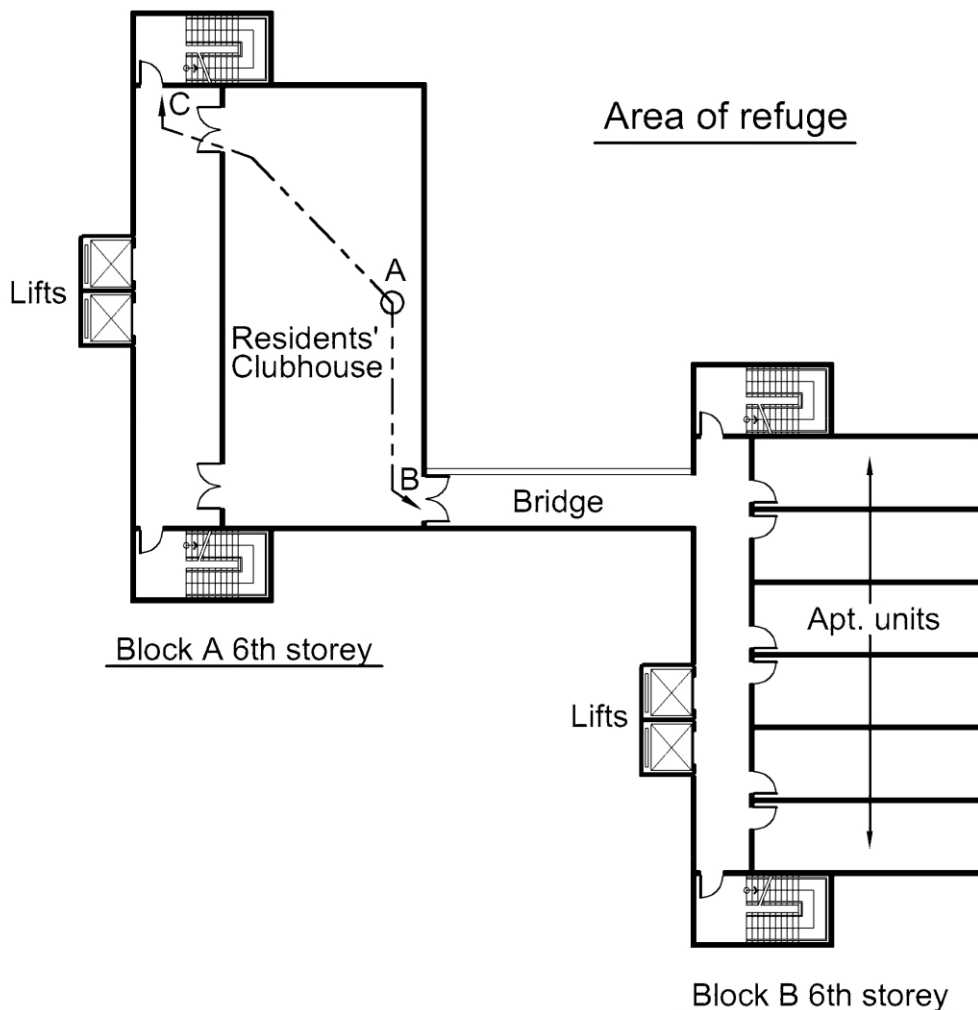

Diagram 2.2.6 (f)-1

EXPLANATIONS & ILLUSTRATIONS

2.2.6(f)

Where an area is designated as 'area of refuge' (Building B in diagrams 2.2.6 (f) – 1 & 2), it must have adequate provision of exit staircases to evacuate its own occupant load and half that of that area (Building A) which it serves as area of refuge. Area of refuge acts as a temporary holding area allowing the occupants more time for evacuation. Hence, it shall be protected from the fire and smoke risk from building A via the provision of cross-ventilated bridges or protected external passageways.

While some conditions for the area of refuge is given below, reference shall also be made to Cl.1.2.4 and Cl.2.2.15 for more explanations and details on the area of refuge.

Area of refuge

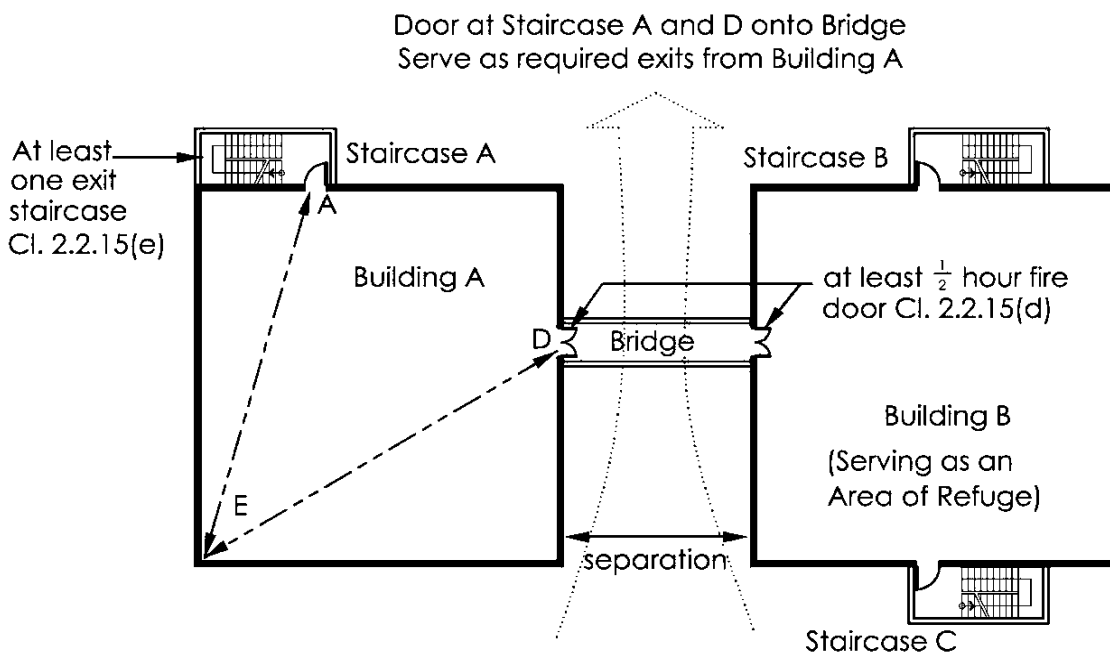

Diagram 2.2.6(f)-2

Lines EA and ED are taken as two-way Direct Distance Measurements.

General conditions for Area of Refuge

- * Occupant Load for Area of Refuge to be based on $0.3m^2$ per person.
- * Each connecting area shall have at least one protected staircase or exit facility of adequate width discharging at ground level.
- * Access door to area of refuge shall be kept accessible at all times
- * Door No 1, {in diagram 2.2.6 (f) – 2} leading to area of refuge can also be treated as a required exit from the area served by it, and hence travel distance can also be measured to this door.

EXPLANATIONS & ILLUSTRATIONS

2.2.6(f)

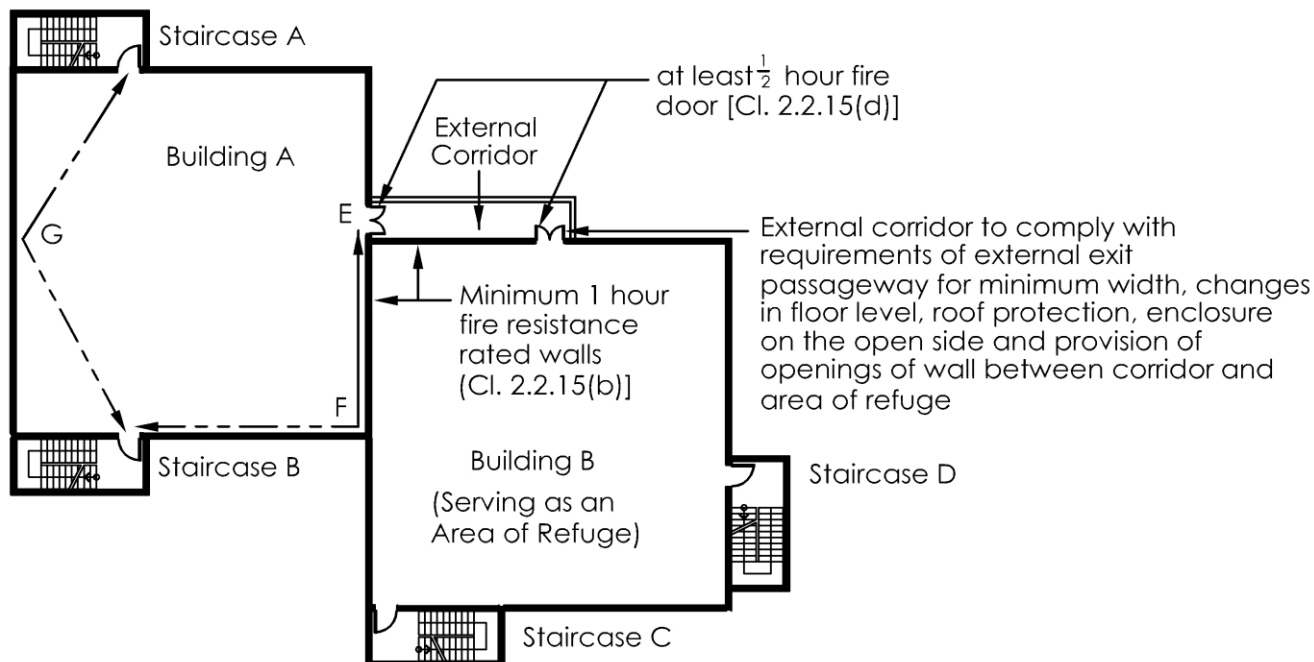

Diagram 2.2.6(f)-3

General conditions for Area of Refuge

- Area of Refuge shall be adequate in size to hold the occupant load it receives from Building A, in addition to its own occupant load calculated on the basis $0.3m^2$ per person.
- Each connecting area or floor served by an Area of Refuge shall have at least one protected staircase or exit facility of adequate width discharging at ground level.
- Access door to area of refuge shall be kept accessible at all times
- Door D & E, {in diagrams 2.2.6 (f) –2&3 respectively} leading to area of refuge can also be treated as a required exit from the area served by it, and hence travel distance can also be measured to these doors.



- (g) Where permitted under Cl.2.3.3 for exit staircases to be entered without the provision of an exit door, the travel distance shall be measured to a position where the exit door would be installed if otherwise required.

EXPLANATIONS & ILLUSTRATIONS

2.2.6

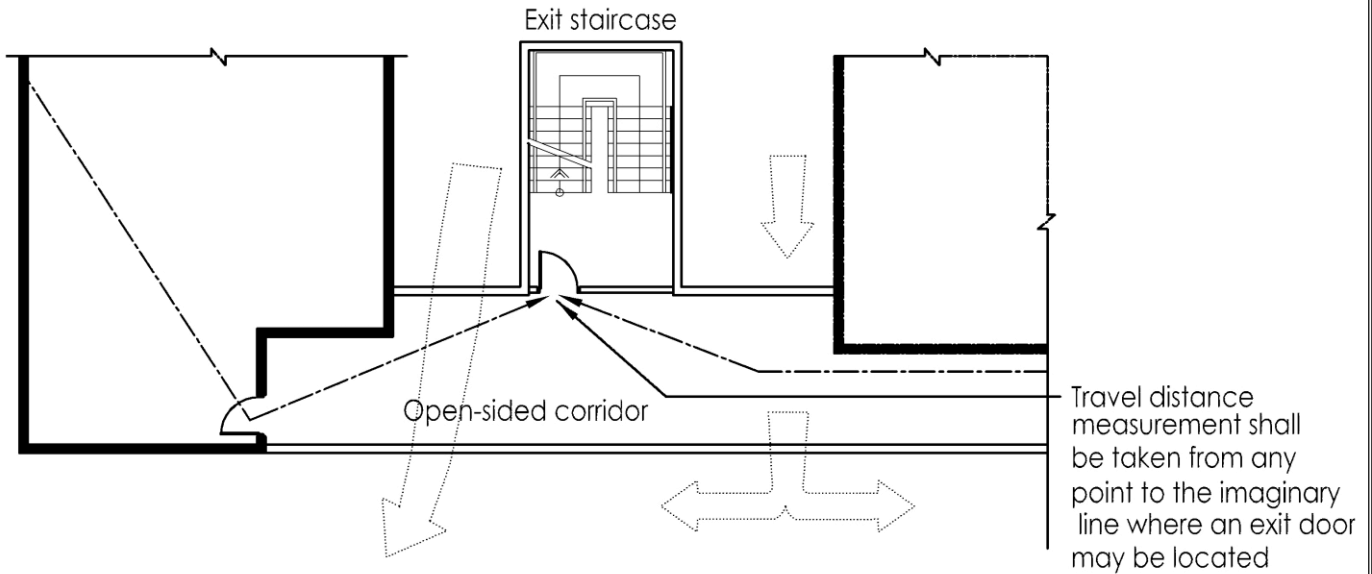

Diagram 2.2.6(g)

- (h) Where an ancillary office is housed within a space belong to other purpose groups, the travel distance requirement for the ancillary office is allowed to be based on Purpose Group IV, provided:
- (i) the ancillary office is fire compartmented from spaces belonging to the other purpose groups; and
 - (ii) the ancillary office occupants shall have access to exit(s) within the ancillary office compartment leading to direct discharge at ground level into a safe exterior open space, into a protected exit staircase or internal/external exit passageway.

EXPLANATIONS & ILLUSTRATIONS

2.2.6

EXAMPLE OF SEPARATE TRAVEL DISTANCE APPLICATION

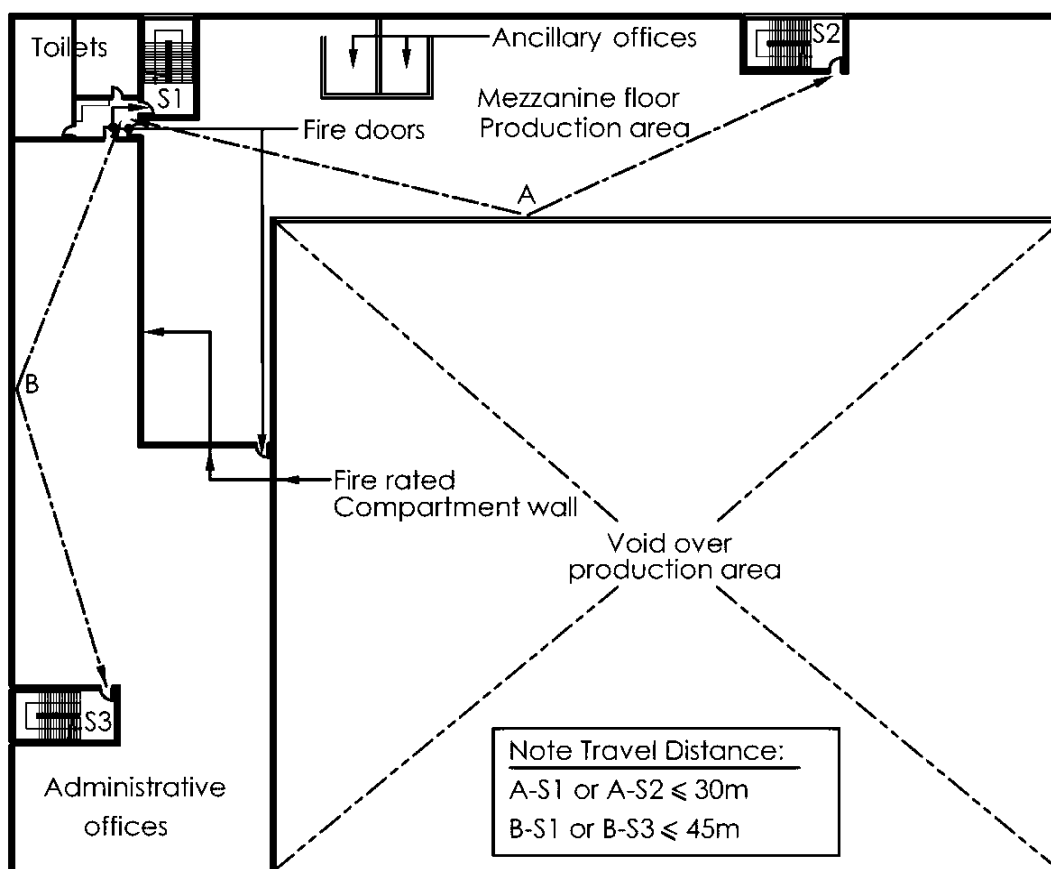

Diagram 2.2.6(h)

The fire risk in office space is lower than factory space. If there is fire separation between office and factory spaces as shown above, the travel distance requirement for the ancillary office is allowed to be based on office use under Purpose Group IV.



CHAPTER 2

2.2 DETERMINATION OF EXIT REQUIREMENTS

2.2.7 Minimum width

(a) No exit, exit staircase or other exit facilities shall be narrower than the minimum width requirement as specified under Table 2.2A. The minimum clear width of an exit door opening shall be not less than 850mm.

EXPLANATIONS & ILLUSTRATIONS

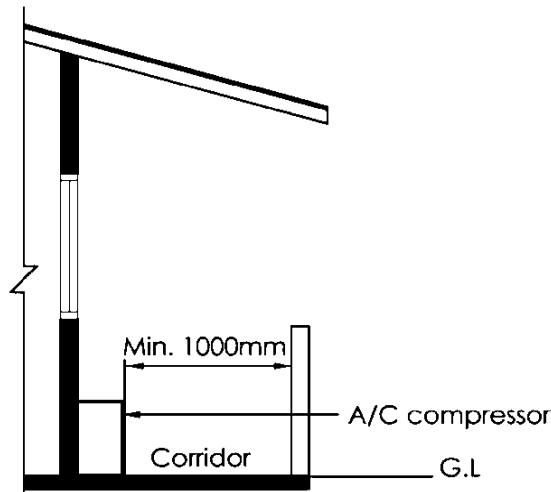

Sectional Elevation

Diagram 2.2.7-1

Other exit facilities refer to passageways, defined corridors, etc.

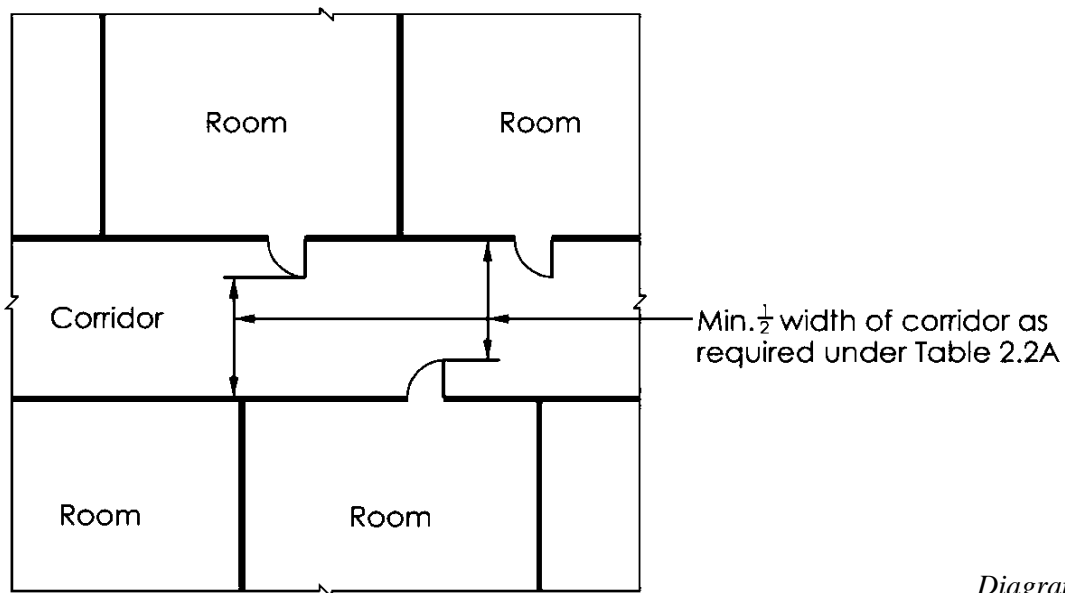

Diagram 2.2.7-2

EXPLANATIONS & ILLUSTRATIONS

2.2.7

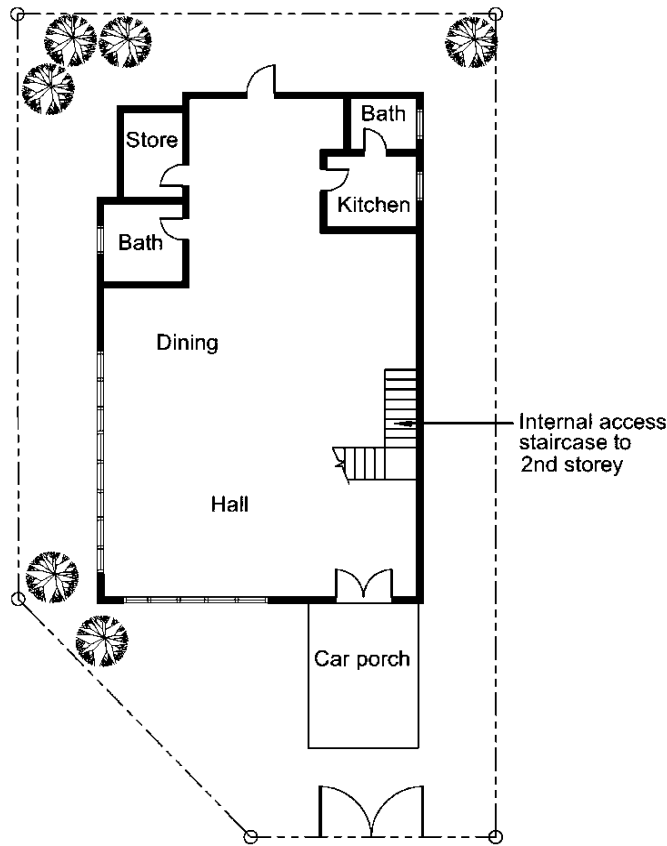

Diagram 2.2.7-3

In the case of Purpose Group I dwelling unit, the minimum width of corridor and access staircase is 900mm. This relaxation is not applicable to all other purpose group buildings.

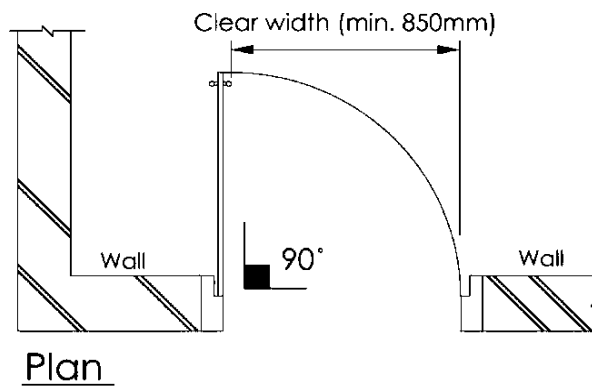

Diagram 2.2.7-4

Clear width of exit door opening shall not be less than 850mm. It shall be measured clear of any protrusion except doorknob or lockset, subject to complying with exit requirements. 850mm is equivalent to 1½ units of width only, for the purpose of determining the exit capacity.



EXPLANATIONS & ILLUSTRATIONS

2.2.7

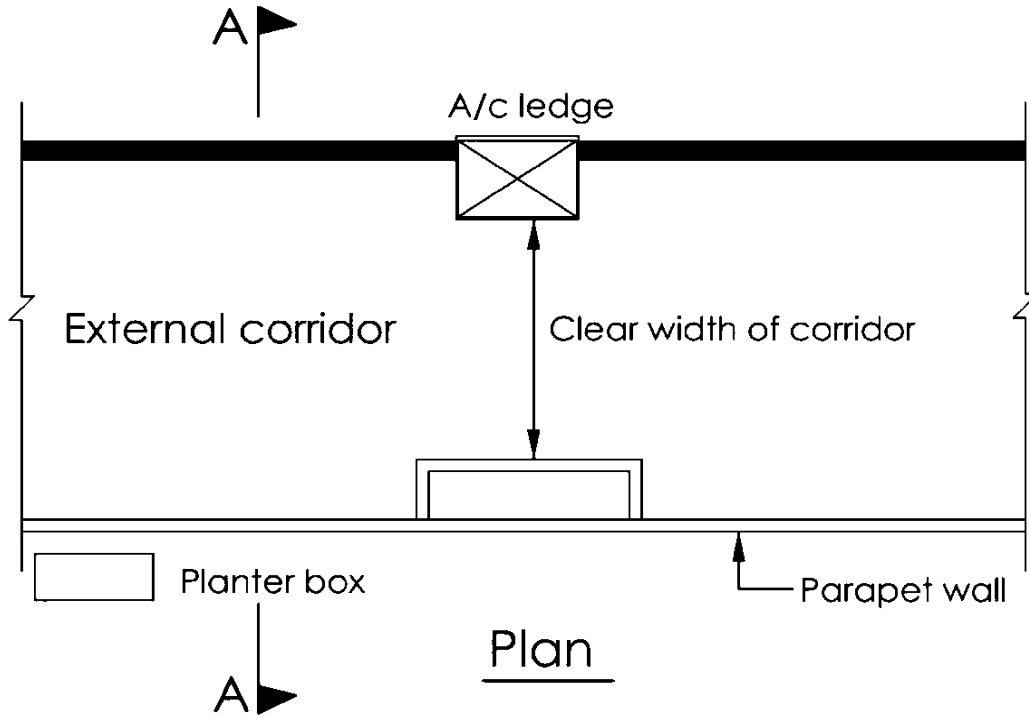

Diagram 2.2.7-5

Clear width of corridor leading to an exit shall not be less than 1200m

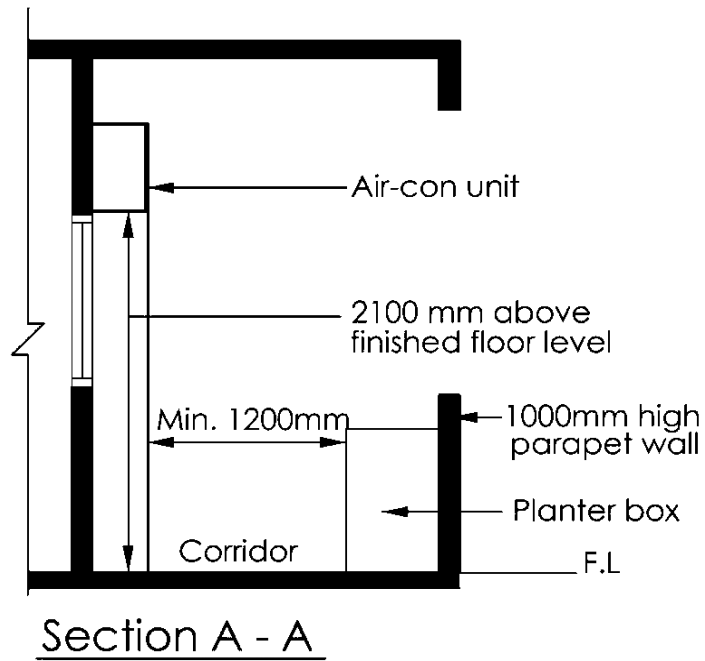

Diagram 2.2.7-6

EXPLANATIONS & ILLUSTRATIONS

2.2.7

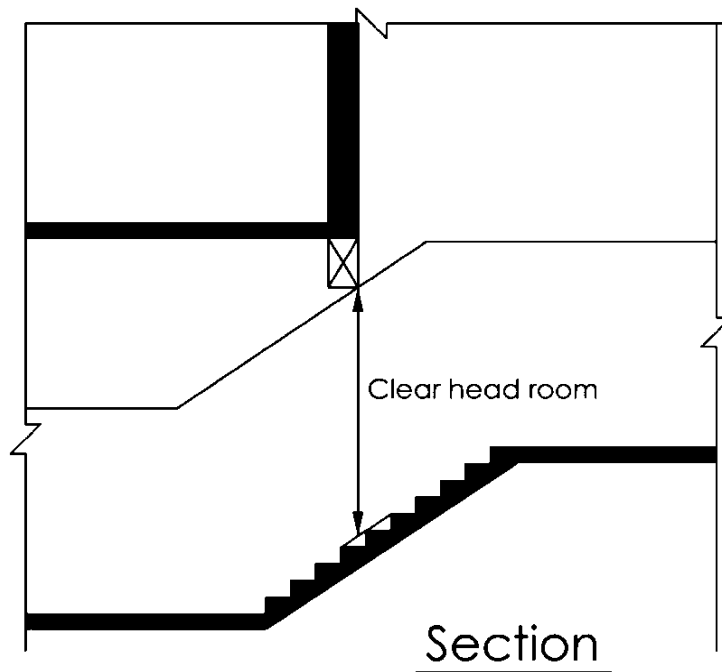

Diagram 2.2.7-7

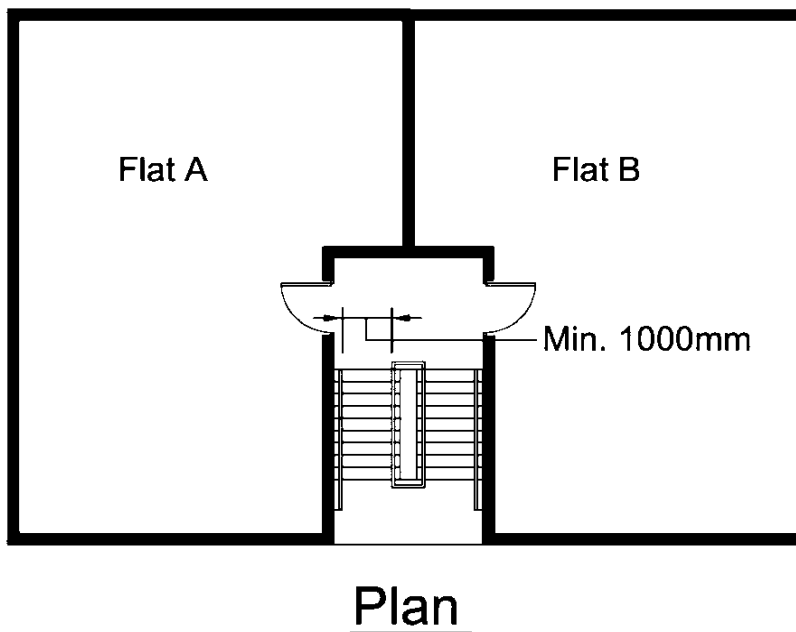

Diagram 2.2.7-8

Clear width of exit staircase shall not be less than 1000mm. Please refer to Cl.2.2.9 (a) for details on measuring of width

EXPLANATIONS & ILLUSTRATIONS

2.2.7

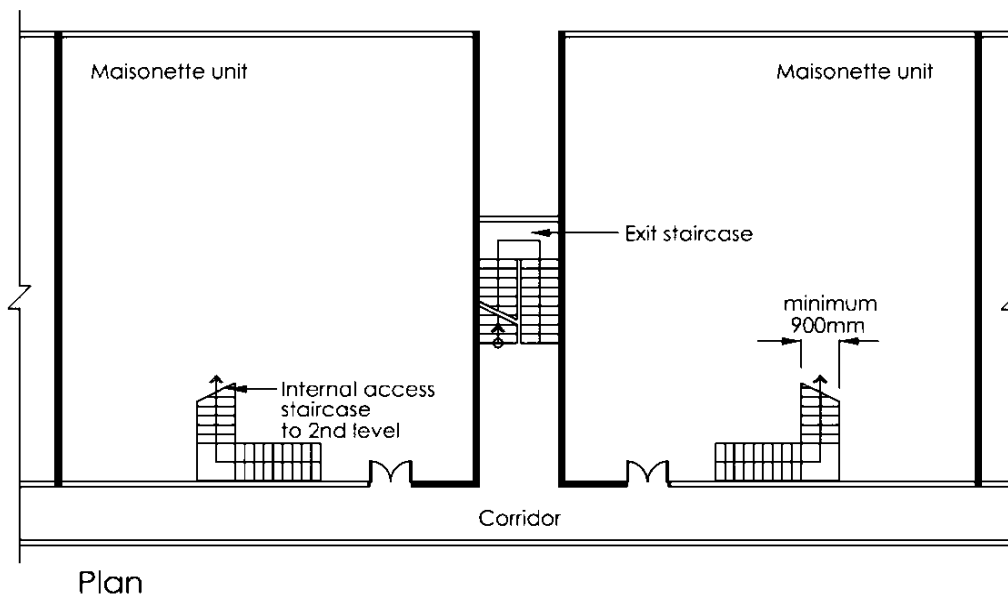

Diagram 2.2.7-9

Clear width of internal access staircase in maisonette unit can be less than 1m but not less than 900mm. This relaxation is only permitted for Purpose Group I residential building.

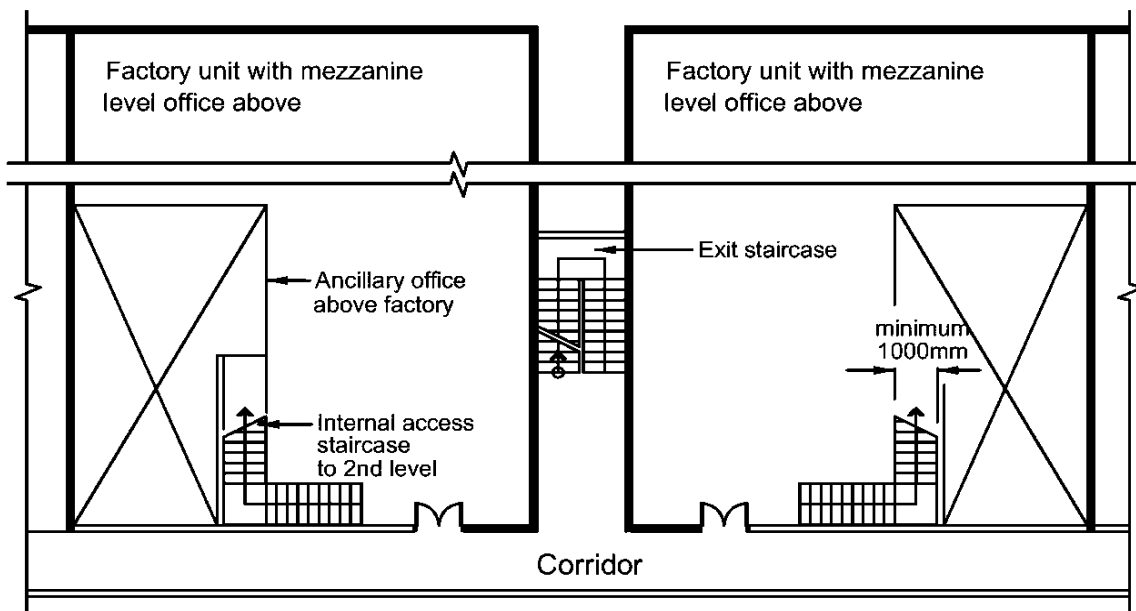

Diagram 2.2.7-10

Clear width of internal access staircase in factory unit with mezzanine level office shall not be less than 1000mm. The One-way travel distance from the most remote point of the ancillary office on mezzanine level to the exit door on the main storey level of factory shall not exceed the permissible limits of Table 2.2A.



(b) Exit access doors serving a room with an occupant load of not more than 2 persons shall not be less than 610mm in clear width.

EXPLANATIONS & ILLUSTRATIONS

2.2.7

Such door width is only applicable to small room i.e office with occupant load of not more than 2 persons.



(c) A single leaf swing door along the means of egress shall not exceed 1250mm in clear width.

EXPLANATIONS & ILLUSTRATIONS

2.2.7

The purpose of controlling the single leaf door not exceeding 1200mm in width is intended to discourage the use of bigger, heavier leaf doors. This is because there is risk of door sagging and thus require more effort to open the door. To overcome it, double-leaf doors should be used in larger openings instead of single leaf swing door.

CHAPTER 2

2.2 DETERMINATION OF EXIT REQUIREMENTS

2.2.8 Maximum width

The maximum width of exit staircases shall be not more than 2000mm. Where staircases exceed 2000mm in width, handrails shall be used to divide the staircase into sections of not less than 1000mm of width or more than 2000mm of width.

For the purpose of determining the exit capacity of a staircase that is wider than 2000mm that forms part of the required means of escape from any storey of the building, that part of its width in excess of 2000mm shall not be taken into account.

EXPLANATIONS & ILLUSTRATIONS

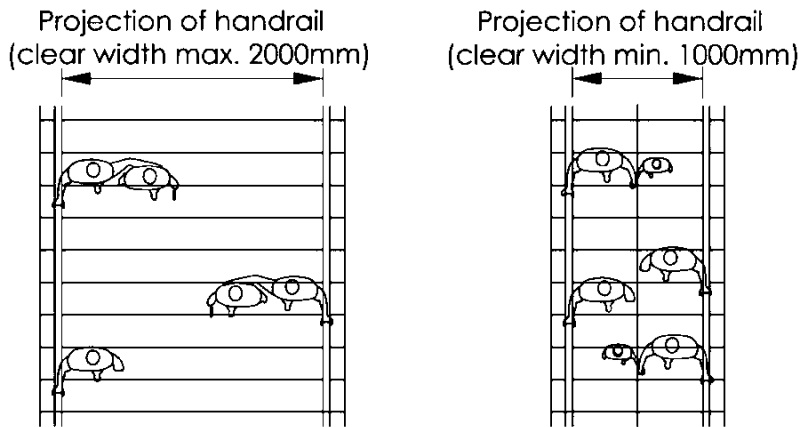

Diagram 2.2.8-1

The above sub clause does not preclude the design of staircases wider than 2000mm. It is intended to limit the number of occupants to be allocated to a single exit staircase, and thereby, prevent the concentration of the occupant's escape at any one point of exit. The consequences, if higher capacity is to be permitted through an exit without capping would be disastrous, if that staircase is to be rendered unusable, in an emergency situation.

Hence, where a staircase is designed with a width greater than 2000mm, its total exit capacity shall be based on the capacity of only 4 units of exit width when determining the adequacy of exit provisions from that storey of building served by that staircase.

This staircase is also required to be sub-divided equally into 2 or more sections with handrails such that the spacing between the handrails are not less than 1000mm and not more than 2000mm.

EXPLANATIONS & ILLUSTRATIONS

2.2.8

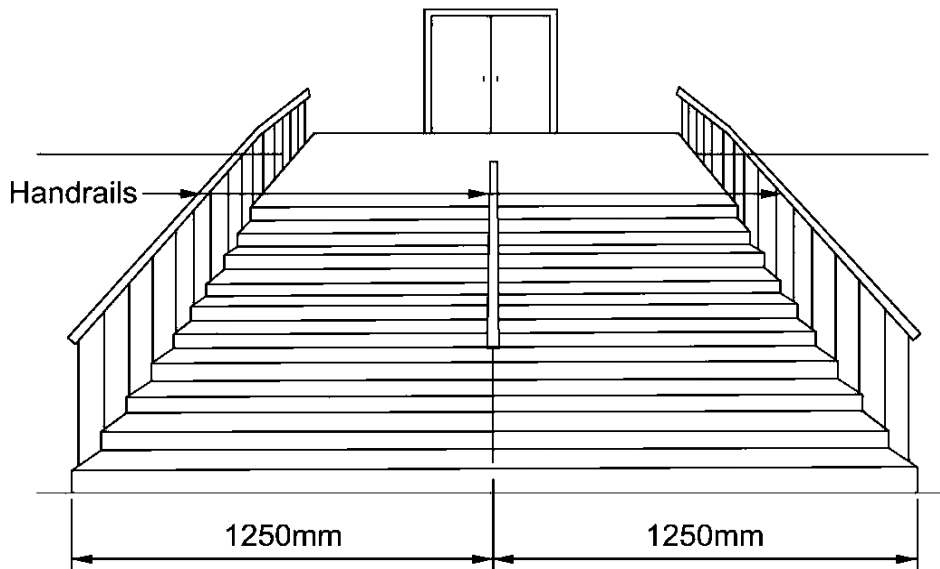

Diagram 2.2.8-2

Assumed natural path of travel

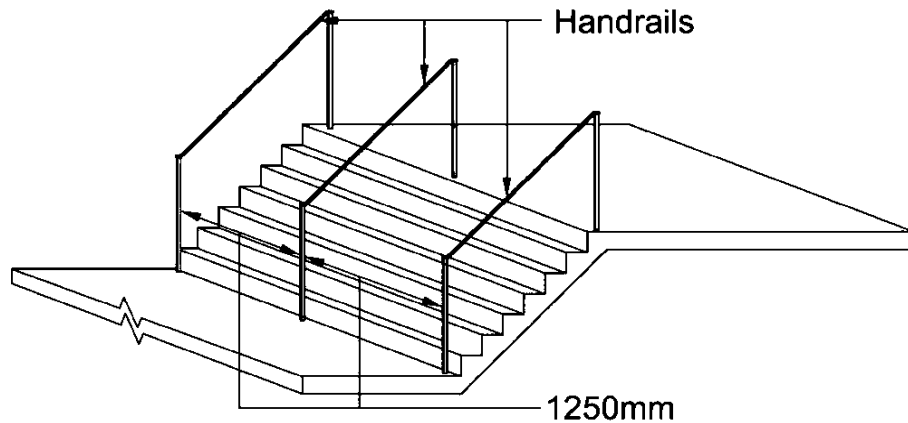

Diagram 2.2.8-3

The width of staircase of 2500mm is being divided into 2 sections of 1250mm each by the introduction of an intermediate handrail. Although the staircase is 2500mm clear, it is still computed as 2000mm only. Dividing staircase wider than 2000mm enables better crowd control and orderly evacuation in times of emergency.

CHAPTER 2

2.2 DETERMINATION OF EXIT REQUIREMENTS

2.2.9 Measurement of width

The measurement of width referred to under Clauses 2.2.7 and 2.2.8 shall be the clear width, including the width of plinth to balustrade or parapet wall:

(a) In the case of an exit staircase, between –

(i) the finished surfaces of the walls, if the staircase is enclosed on both sides by walls only, or

EXPLANATIONS & ILLUSTRATIONS

Diagram 2.2.9(a)(i)



- (ii) the finished surface of the wall and the inner side of the balustrade, if the staircase has a wall on one side and a balustrade on the other side, or

EXPLANATIONS & ILLUSTRATIONS

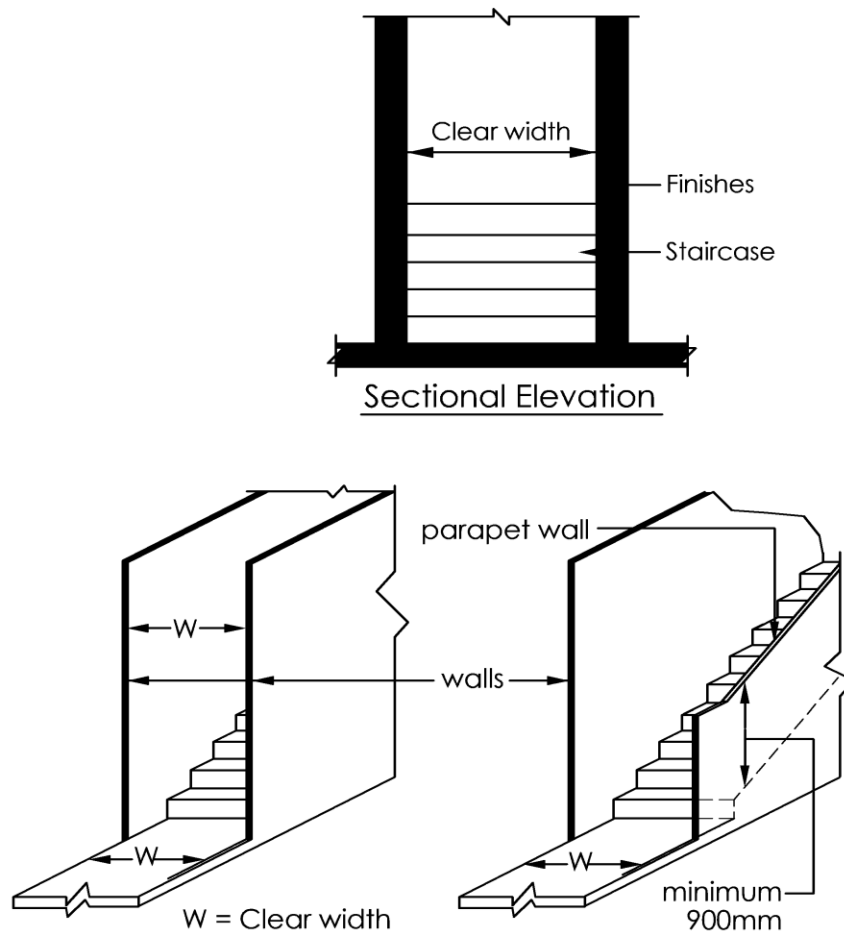
2.2.9(a)

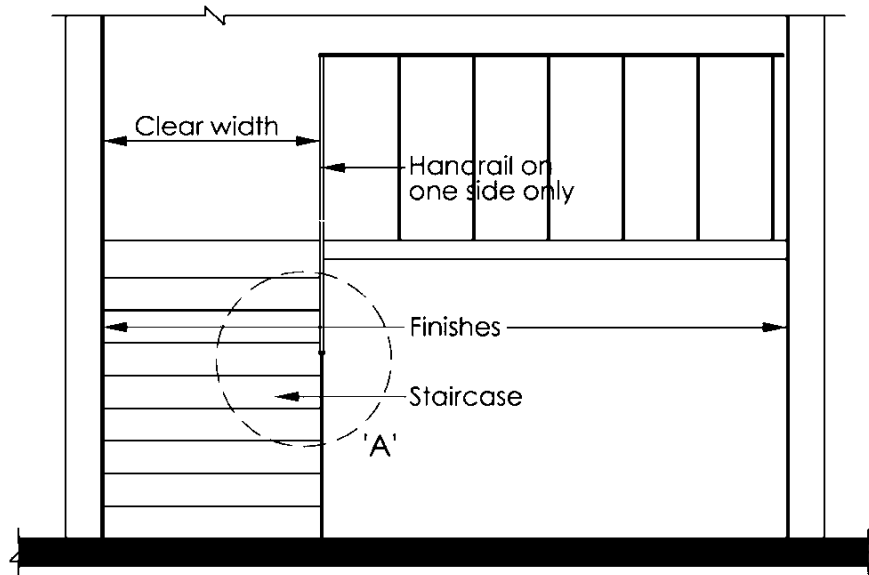

Diagram 2.2.9(a)(ii)-1

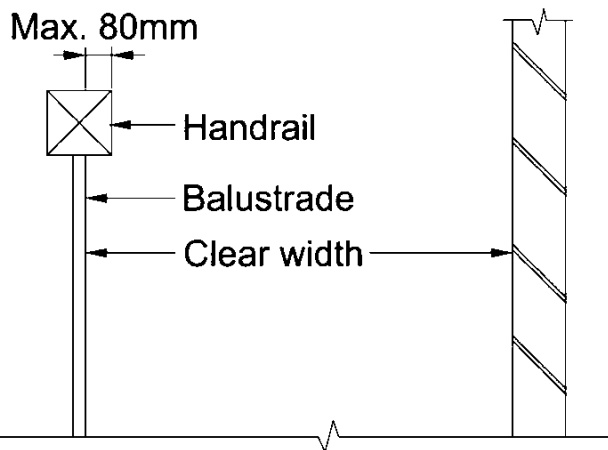

Diagram 2.2.9(a)(ii)-2



(iii) the inner sides of the balustrades if the staircase has balustrades on both sides, and the projection of handrail into the clear width of a staircase shall not exceed 80mm on each side of the staircase. If the projection exceeds 80mm, the clear width of the staircase shall be measured from the inner sides of the handrails.

EXPLANATIONS & ILLUSTRATIONS

2.2.9(a)

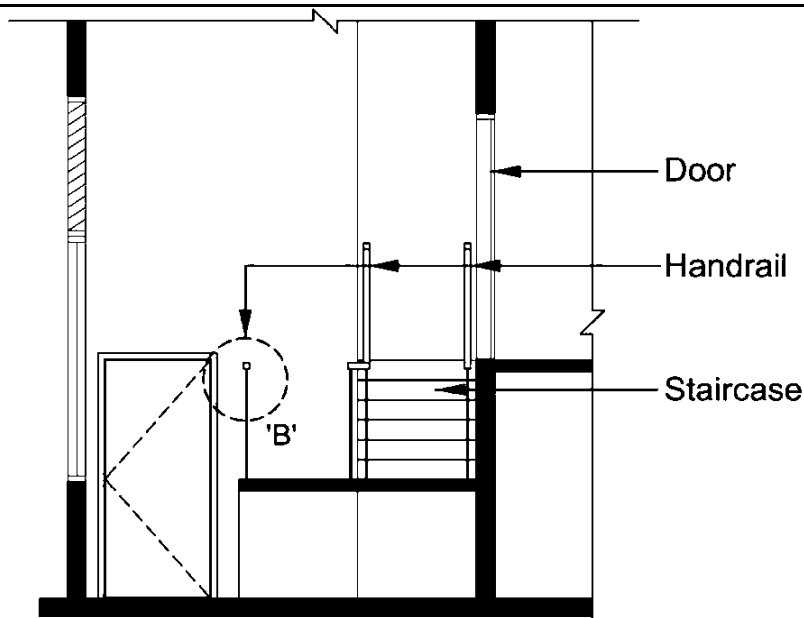

Sectional Elevation

Diagram 2.2.9(a)(iii)-1

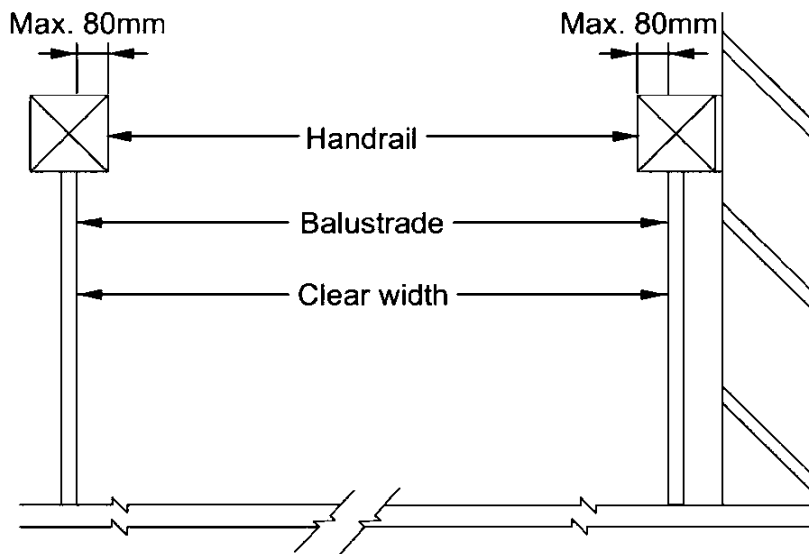

Detail B

Diagram 2.2.9(a)(iii)-2



EXPLANATIONS & ILLUSTRATIONS

2.2.9(a)(iii)

Example of handrail protection >80mm

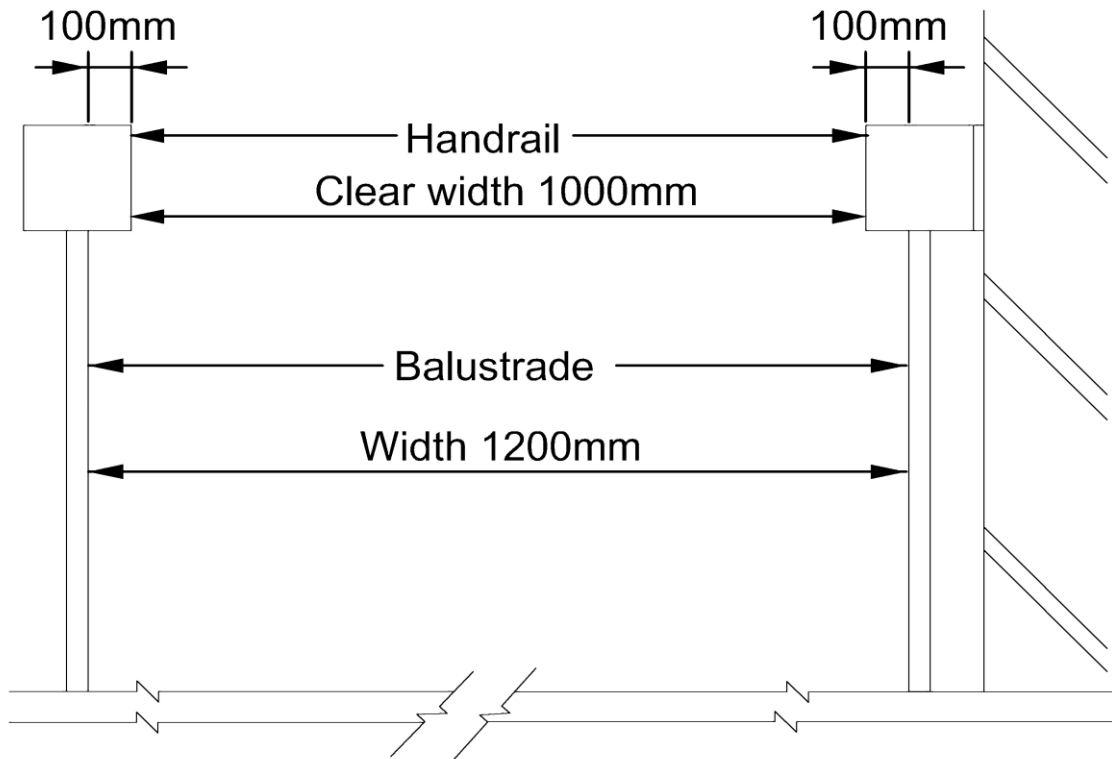

Detail B

Diagram 2.2.9(a) (iii)-3

If the projection of handrail exceeds 80mm, the clear width shall be measured between the inner sides of the handrails.



- (b) (i) In the case of an exit door having a single leaf door, the opening shall be measured between the edge of the door jamb and the surface of the door when opened at an angle of 90 degrees (See diagram 2.2.9(b)); and
- (ii) In the case of an exit door having 2-leaf and fitted with an approved automatic flush bolt, the clear openings shall be measured between the surface of one leaf to the other door leaf when opened at an angle of 90 degrees; an
- (iii) If one of the door leaves is bolted to the door frame and/or floor by a manually operated bolt, this door leaf shall not be considered for the purpose of determining the exit capacity of the door. The opening of the other door leaf shall have a clear width of not less than 850mm, measured between the edge of the bolted door leaf and the surface of the other door leaf, when opened at an angle of 90 degrees;
- (iv) Door hardware and handrails which do not protrude more than 80mm into the clear width of exit opening can be ignored.

EXPLANATIONS & ILLUSTRATIONS

2.2.9

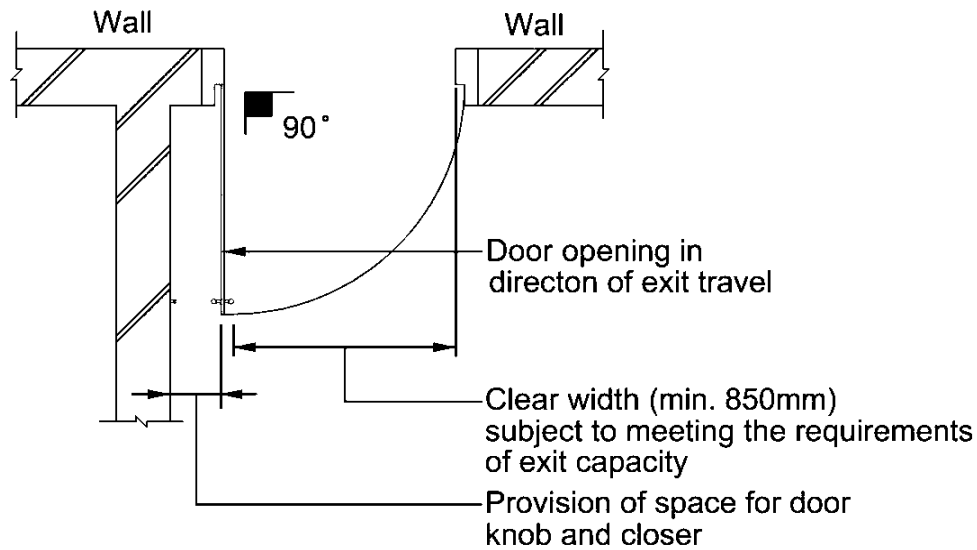

Plan - Single Leaf Door

Diagram 2.2.9(b)-1



EXPLANATIONS & ILLUSTRATIONS

2.2.9(b)

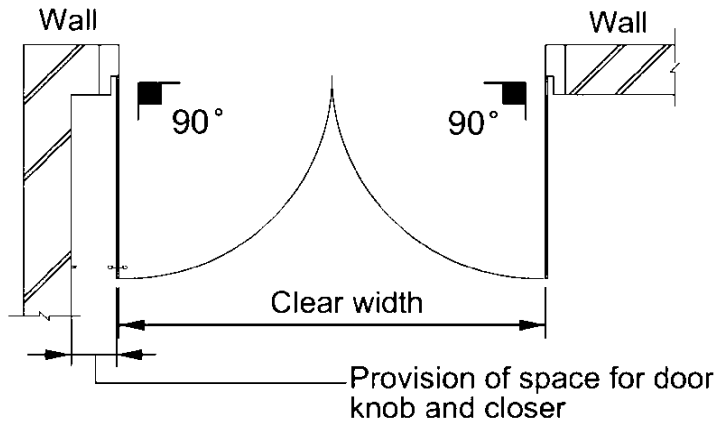

Plan - Double Leaf Door

The terminology “2-leaf” is generally known as “multi-leaf-door” a common term in the building industry. It may comprise of leaf door panels of different sizes. The smaller leaf door may be bolted onto the floor and opened only to facilitate shifting of bulky items. The smaller leaf door if intended to be kept in closed position and not use as escape, it need not be provided with door closer.

Diagram 2.2.9(b)-2

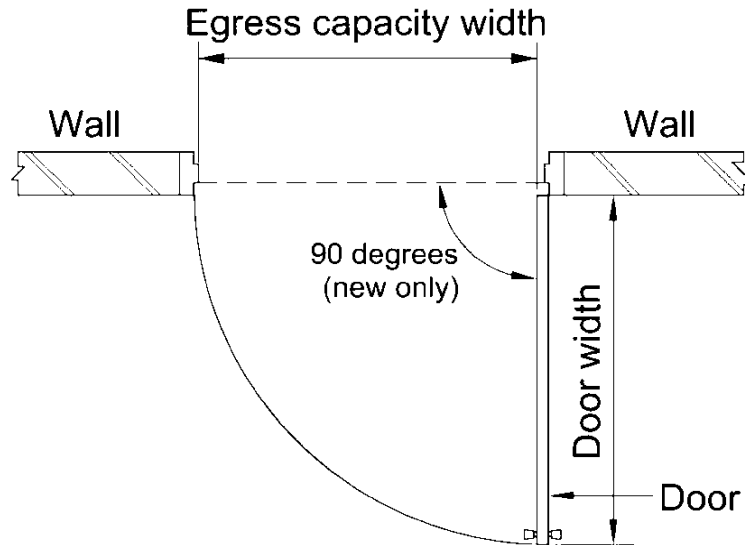

Minimum clear width

Diagram 2.2.9(b)-3

Determining the egress width of swinging doors for purposes of calculating capacity, only the clear width of the doorway when the door is open 90 degrees shall be measured. In determining the egress width for other types of doors for purposes of calculating capacity, only the clear width of the doorway when the door is in the full open position shall be measured. Clear width of doorways shall be measured between the face of the door and door frame



CHAPTER 2

2.2 DETERMINATION OF EXIT REQUIREMENTS

2.2.10 Number of exits from rooms and spaces

There shall be at least two door openings remote from each other and leading to exits from every room or enclosed space in which the total occupant load exceeds the maximum permissible occupant load for one door as listed in the table below:

Type of Occupancy	Maximum Occupant Load with One Door
High Hazard	25
Patient accommodation area	50
Classrooms	50
Godowns, stores, and factories not being of high hazard type	50
Assembly	50

Rooms and spaces with occupancy of more than 50 persons shall comply with the requirements for 'Number and Width of Exits' under Cl.2.8.2 for Assembly Occupancy.

Note:

- i. For residential occupancy, see cl.2.4.
- ii. For health care occupancy, see cl.2.5.
- iii. For office/shop/factory/warehouse occupancy, see cl.2.6
- iv. For hotels, see cl.2.7.
- v. For assembly occupancy, see cl.2.8.

EXPLANATIONS & ILLUSTRATIONS

No illustration.

The table to clause 2.8.2 is reproduced for easy reference.

<i>No of Occupants</i>	<i>Min No of Doors</i>	<i>Min. Width of Corridors</i>
<i>51- 200</i>	<i>2</i>	<i>1200 mm</i>
<i>201 - 500</i>	<i>2</i>	<i>1250 mm</i>
<i>501 - 1000</i>	<i>3</i>	<i>1250 mm</i>
<i>exceeding 1000</i>	<i>4</i>	<i>1250 mm</i>



CHAPTER 2

2.2 DETERMINATION OF EXIT REQUIREMENTS

2.2.11 Number of exit staircases or exits per storey

There shall be at least two independent exit staircases or other exits from every storey of a building, unless otherwise permitted under other subsequent provisions of the code.

EXPLANATIONS & ILLUSTRATIONS

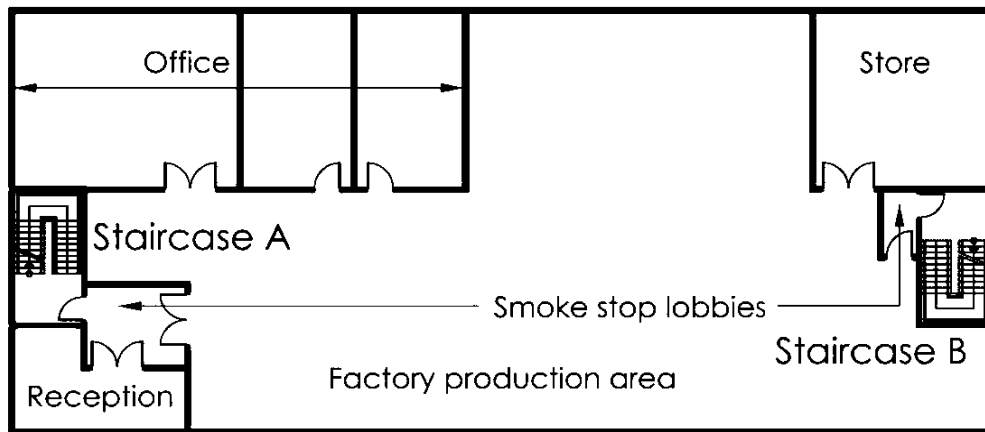

Diagram 2.2.11

Minimum requirement – 2 Exit Staircases per storey

Single exit is permissible if the storey of the building can satisfy the conditions stipulated in clauses 2.2.10 and 2.6.

Single staircase provision is permitted for residential building under Cl. 2.4.4, Cl. 2.4.5 & Cl. 2.6.1.



CHAPTER 2

2.2 DETERMINATION OF EXTI REQUIREMENTS

2.2.12 Location of exits & access to exits

All exits and access facilities shall be required to comply with the following:

- (a) Exits and access facilities shall be clearly visible or their locations shall be clearly indicated and shall be kept readily accessible and unobstructed at all times, and

EXPLANATIONS & ILLUSTRATIONS

No illustration.

Please refer to Chapter 8 for more details.

(b) Every occupant or tenant within a building or storey of a building shall have direct access to the required exit or exits without the need to pass through the spaces or rooms occupied by other occupants or tenants.

EXPLANATIONS & ILLUSTRATIONS

2.2.12

Where any storey of a building is occupied by more than one tenant, it is imperative that each occupant from any of the tenancies shall have direct accessibility to alternate exit staircases without having to enter other tenancies. This could be facilitated via common or neutral spaces like corridors or lobbies that are accessible to all occupants on that storey.

Examples of correct method of determining access travel routes to the required exits:

Multiple Tenancy - each with access to the two exit staircases

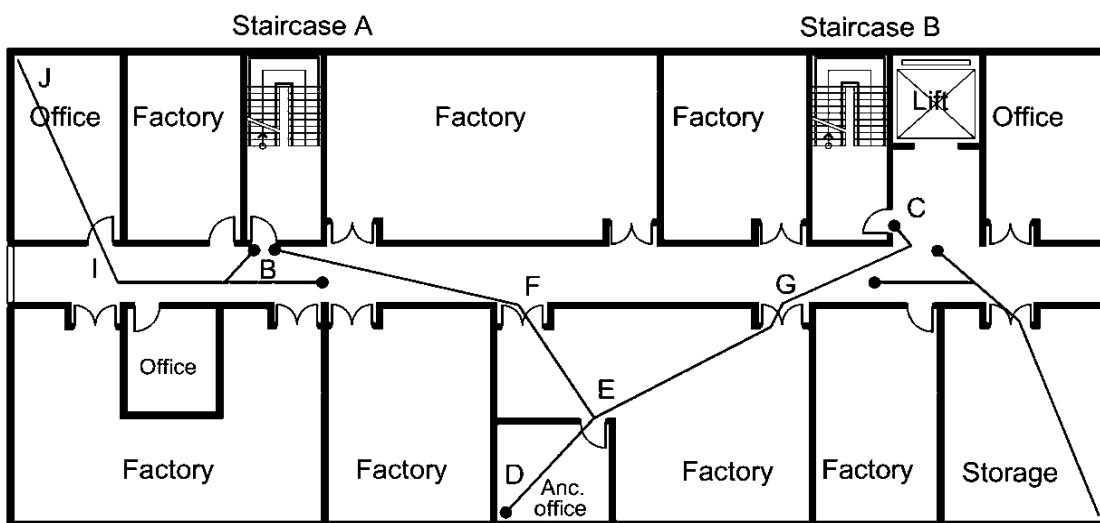

Diagram 2.2.12(b)-1

Two tenancies, both with access to two smoke-stop lobbies

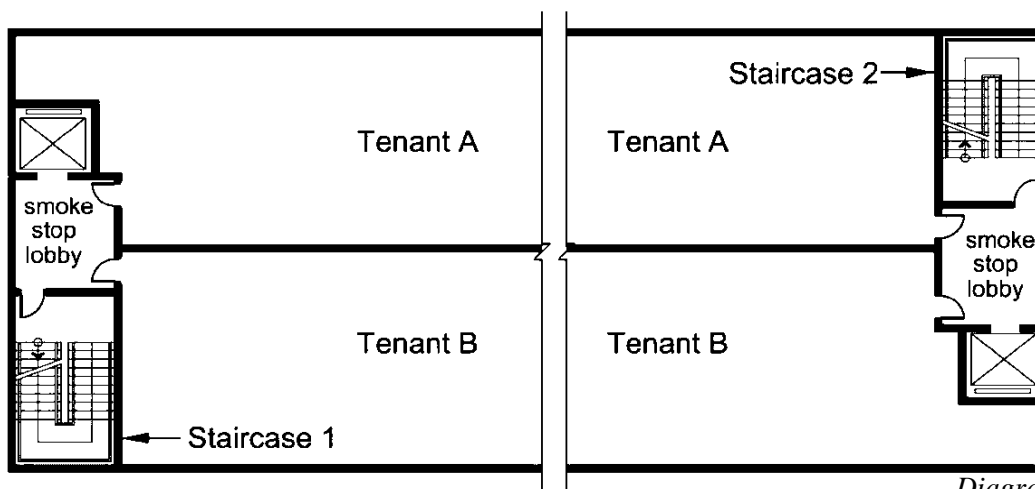

Diagram 2.2.12(b)- 2



EXPLANATIONS & ILLUSTRATIONS

2.2.12(b)

Example of 'incorrect' method of locating exits

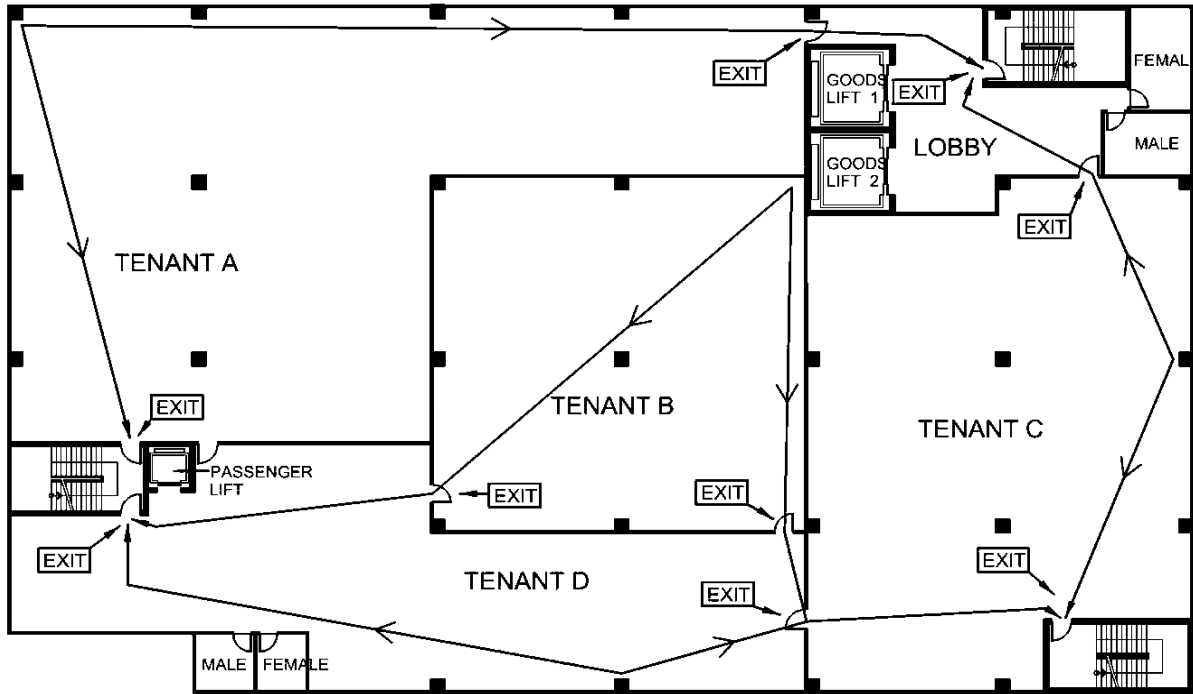

Diagram 2.2.12(b)-3

Diagram 2.2.12 (b) – 3 shows an incorrect method of determining access travel routes as the paths have to traverse through other tenancies. Though tenants A and C may have adequate exits, tenants B and D will not be able to meet required exit provisions and hence it would not be allowed.

Another example of a layout that is NOT Acceptable

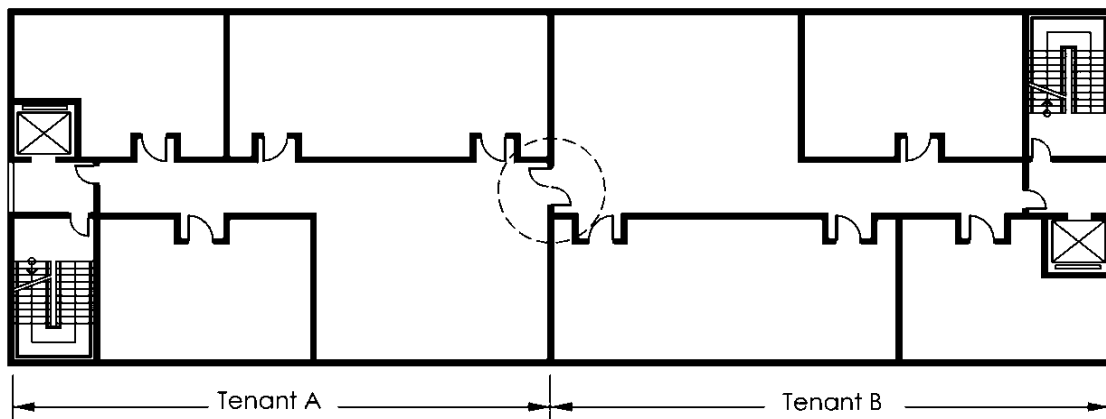

Diagram 2.2.12(b)-4

This arrangement of exits for the separate tenancies is not acceptable because the central door, circled in diagram 2.2.12 (b) – 4, would be kept locked for security reasons and to prevent or avoid any intrusion from one another. This would render the occupants from that storey with insufficient number of exits for escape in an emergency.

(c) When more than one exit is required from any room or space or a storey of a building, each exit shall be placed as remote as possible from the other as permitted under Cl.1.2.60(a), (b) or (c).

EXPLANATIONS & ILLUSTRATIONS

2.2.12

Acceptable

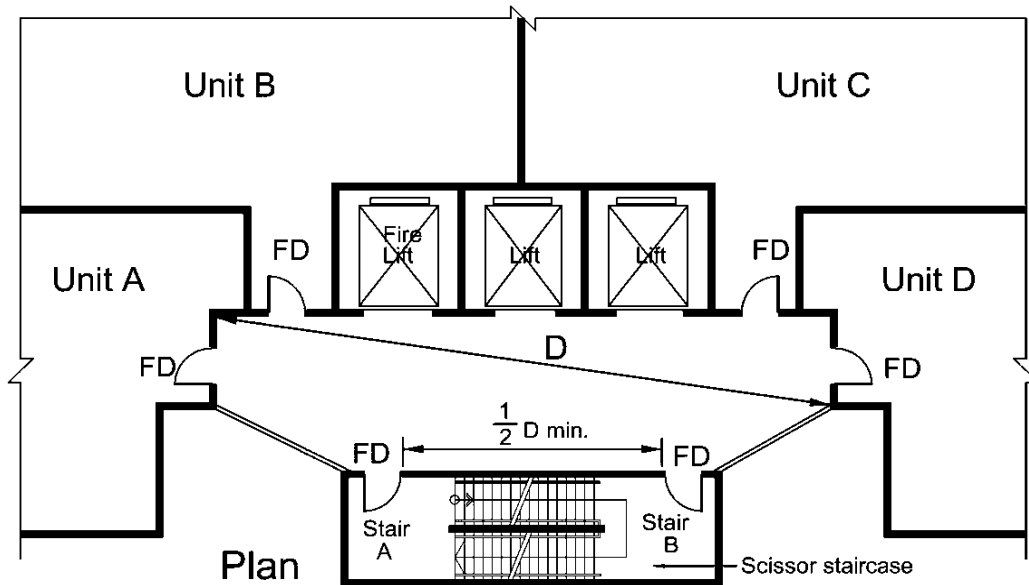

D : Diagonal
FD : Fire door

Diagram 2.2.12(c)-1

The distance between the sides of the two exit doors to the scissor staircases A and B shall be equal to or more than one half the length of the maximum overall diagonal dimension (D) of the lobby, or 7m, whichever is greater. Please refer to CL.2.3.4 as these are conditions for compliance of scissor staircase.

Permanently fixed ventilation openings in the external walls to the lobby shall not be less than 15% of the lobby floor area and located not more than 9m from any part of the lobby (see CL.2.12.13(c) (i)).



EXPLANATIONS & ILLUSTRATIONS

2.2.12(c)

Acceptable

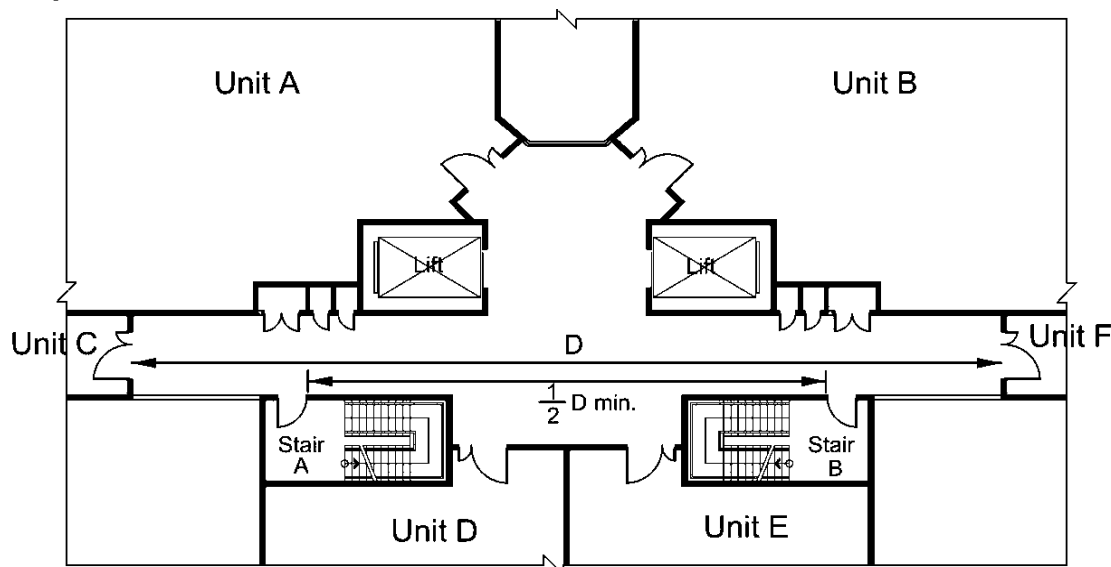

Plan

Diagram 2.2.12(c)-2

This method of measurement for unit exit door is only applicable to residential buildings.

Not Acceptable

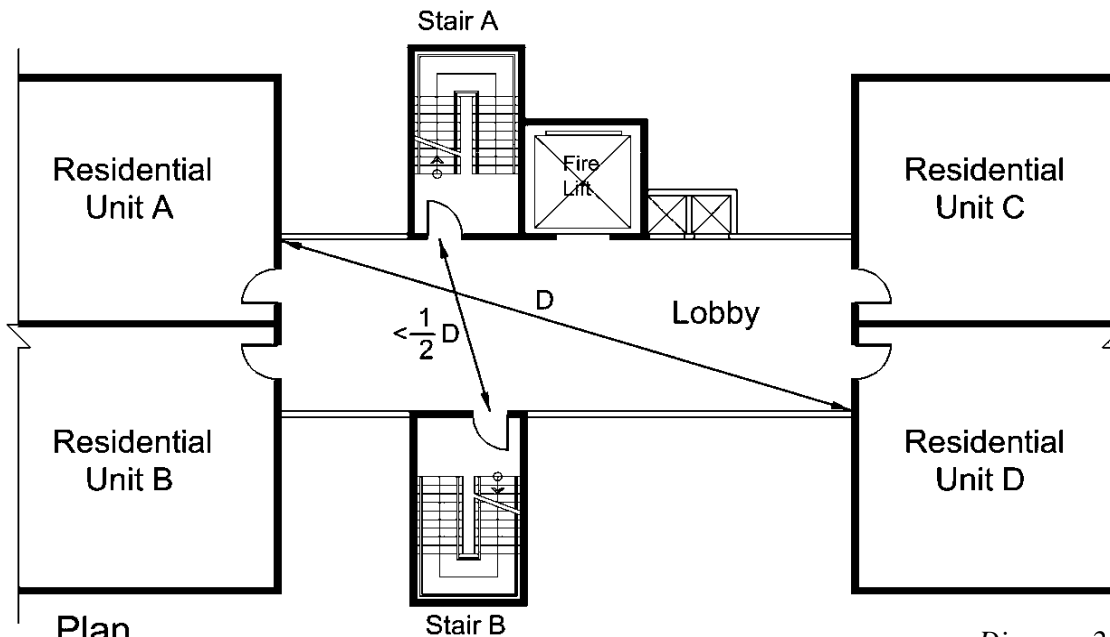

Plan

Diagram 2.2.12(c)

The distance between the sides of two exit doors to the staircases A and B is less than one half the length of the maximum overall diagonal dimension (D) of the lobby.

EXPLANATIONS & ILLUSTRATIONS

2.2.12(c)

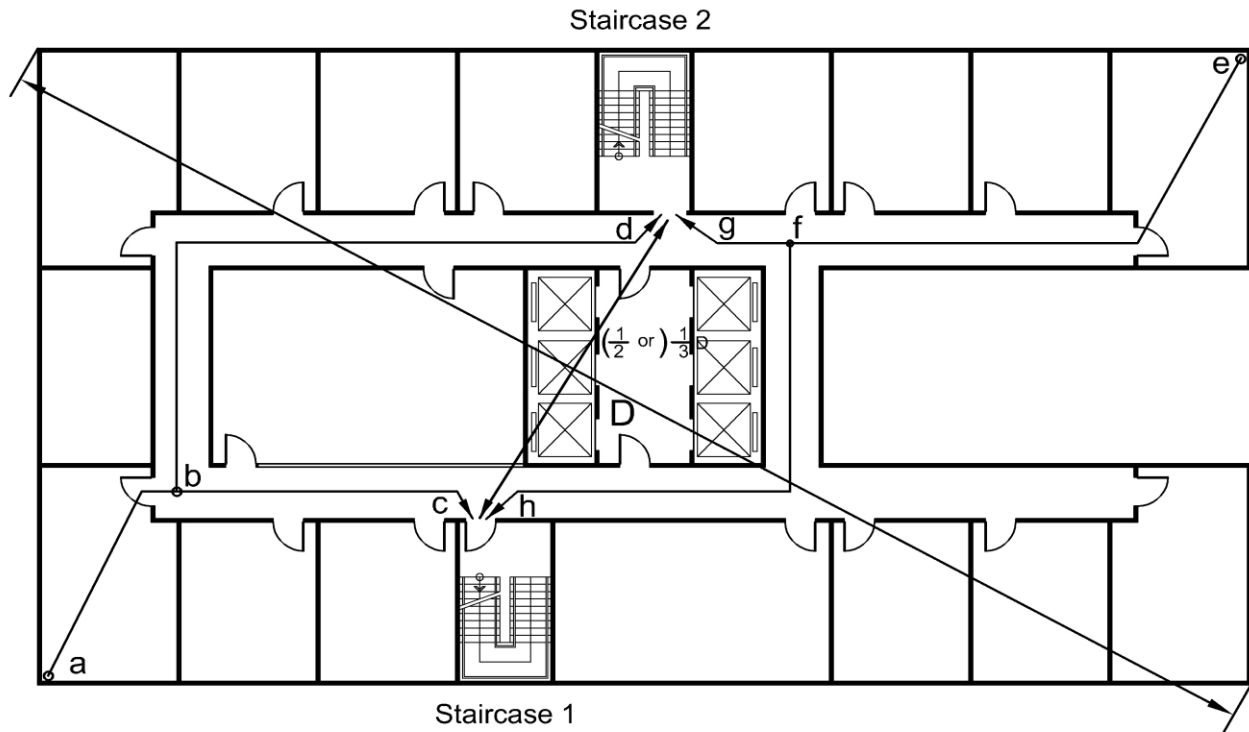

Diagram 2.2.12(c)-4

Distance between exit door to staircase 1 & 2 shall be at least $\frac{1}{2}$ (or $\frac{1}{3}$, if sprinkler protected) the longest diagonal of the building indicated as (D) in the above diagram.

One-way travel distance exists where a space is arranged so that occupants within that space are able to travel in only one direction to reach any of the exits or to reach the point at which the occupants have the choice of two-way travel to remote exits.

For example, the portions of the escape routes from points a to b and e to f are one-way travel, which shall not exceed 15m or 25m (sprinklered). The option to travel in another escape route occurs at points b and f, which provide two-way travel distances to the exit staircases 1 & 2 respectively. One-way travel distances are indicated by the dashed lines. See further illustrations under Cl.1.2.60 (a), (b) or (c).



CHAPTER 2

2.2 DETERMINATION OF EXIT REQUIREMENTS

2.2.13 Smoke free approach to exit staircase

Entry at every storey level (including 1st storey) to an exit staircase of any building or part of a building of more than four storeys above ground level shall be through:

- (a) An external exit passageway or external corridor. The openings for natural lighting and ventilation to the corridor shall be so located that they face and open to:
 - (i) The external space; or
 - (ii) A street, service road or other public space which is open to the sky; or
 - (iii) an air-well which opens vertically to the sky and having a min. width of 6m and a superficial plan area of not less than 93m², except that for residential occupancy, the external corridors for smoke free approach shall comply with the requirements of Cl.2.4.8 and 2.4.9, and in the case of workers' dormitories and hotel bedrooms being served by external corridors, such corridors shall comply with Cl.2.9.4 and Cl.2.7.2 respectively;

EXPLANATIONS & ILLUSTRATIONS

Diagram 2.2.13(a)

Note: A smoke free approach (i.e. smoke-stop lobby) is to be provided for entry into the exit staircases, even at 1st storey.

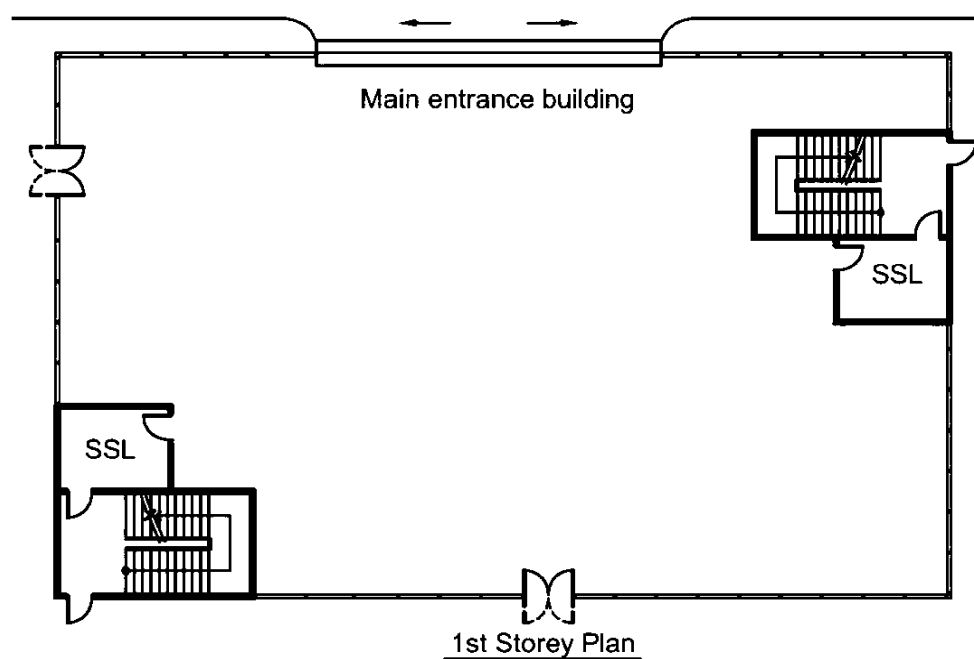

EXPLANATIONS & ILLUSTRATIONS

2.2.13(a) (iii)

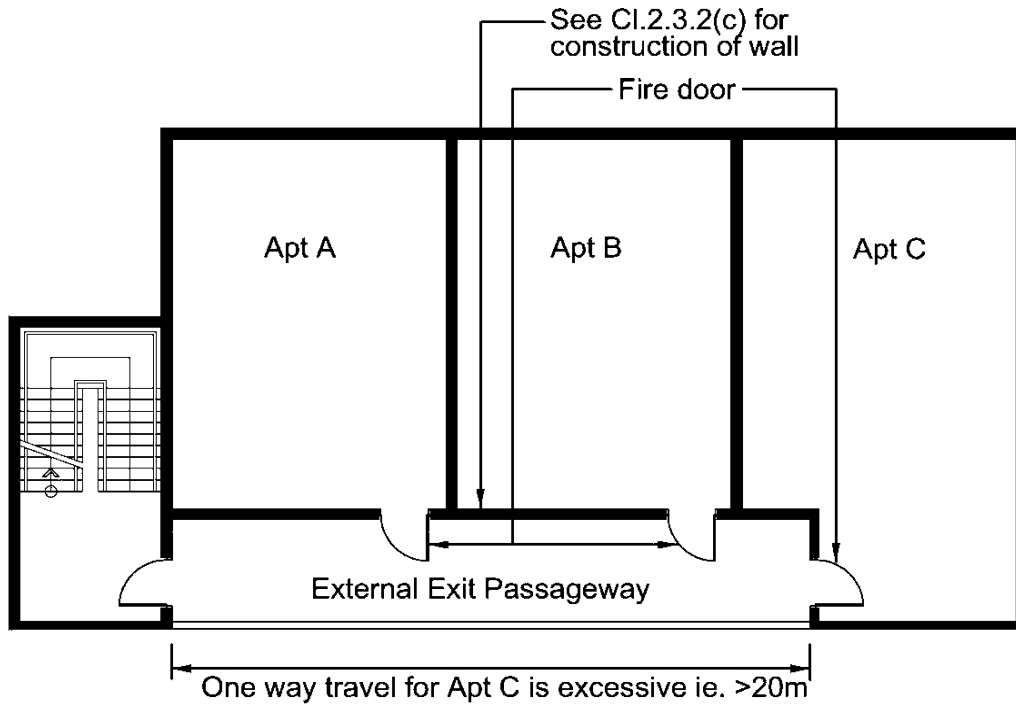

Plan

Diagram 2.2.13(a)(iii)-1

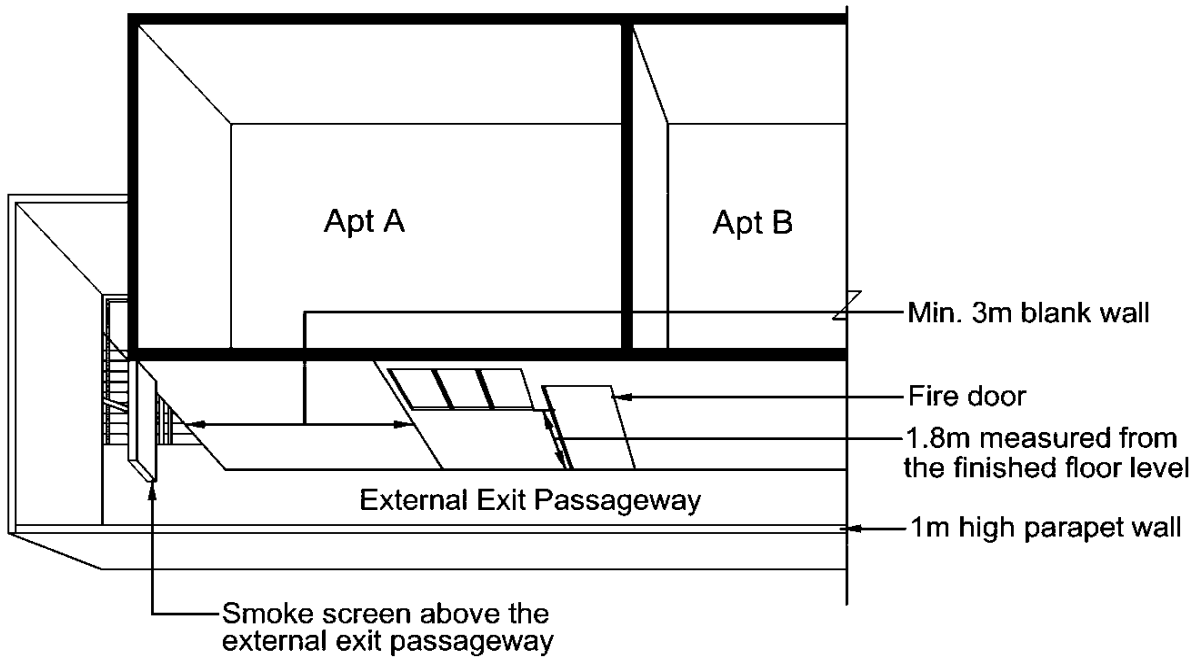
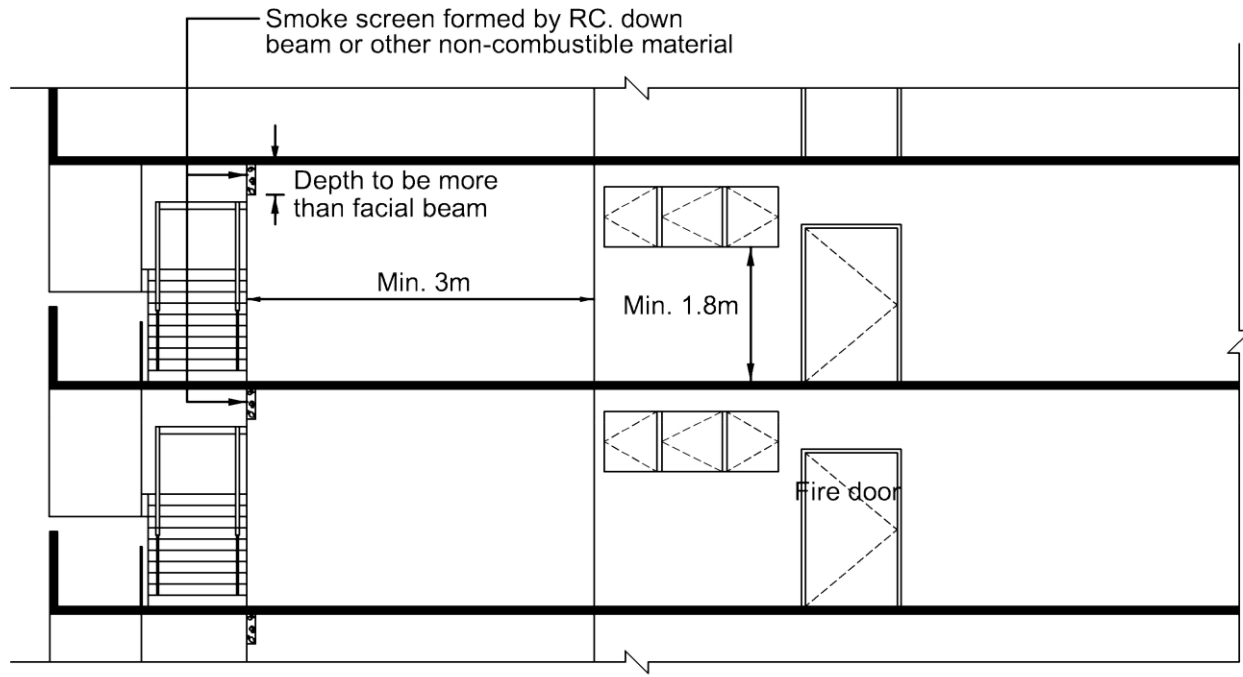

Diagram 2.2.13(a)(iii)-2



EXPLANATIONS & ILLUSTRATIONS **2.2.13(a) (iii)**



Section

Diagram 2.2.13(a) (iii)-3

External exit passageway is a protected area, which is an extension of the vertical exit staircase. It is used to overcome excessive travel distances as shown in the above diagram.

The provision of smoke screen above the passageway before the staircase is to prevent smoke from entering the stairwell at ceiling level.



EXPLANATIONS & ILLUSTRATIONS

2.2.13(a)(iii)

Main differences between external corridor , Smoke-stop lobby and external exit passageway

	External corridor	Smoke Stop Lobby	External exit passageway
Entrance door	No fire rating	At least ½ hour fire rating	At least ½ hour fire rating
Usage	As smoke free approach	As smoke free approach	As extension of the vertical exit (to overcome travel distance deficiency)
Corridor/lobby – air well ventilation	<ol style="list-style-type: none"> 1. Min 1.2m high opening 2. Max 3m roof over 3. 1m <parapet wall <1.1m 4. Air well _Min 6m wide / area 93m² 	<ol style="list-style-type: none"> 1. Opening 15% of lobby area. 2. Max 9m from opening. 3. Air well _ min 6m wide / area 93m² 	<ol style="list-style-type: none"> 1. Min 1.2m high opening 2. Max 3m roof over 3. 1m <Parapet wall <1.1m 4. Comply with table 1.2.1A if facing air well
Cross Ventilation	<ol style="list-style-type: none"> 1. Min 1.2m high opening 2. Max 3m roof over 	<ol style="list-style-type: none"> 1. Opening 50% of opposing wall superficial area 2. Max 13m from opening 3. No obstruction 	<ol style="list-style-type: none"> 1. Min 1.2m high opening 2. Max 3m roof over 3. 1m <Parapet wall <1.1m 4. Comply with table 1.2.1A
Vent openings btw unit & corridor/S.S lobby	Above 1100mm from finished floor level of corridor	No opening allowed	Above 1800mm from finished floor level of passageway
Risers	No fire rating for shaft door	Fire rated shaft and doors	No services allowed
Exposed M&E services (Cl 3.9.6)	Service allowed only if enclosed with fire rated enclosure	No services allowed unless enclosed in 1hr rated enclosure	No services allowed



EXPLANATIONS & ILLUSTRATIONS

2.2.13(a) (iii)

It is important that exit staircases are kept free of any smoke at all times, especially in times of a fire emergency, as it is the main essential means for evacuating occupants from the building. To facilitate this smoke free environment, a buffer zone that can quickly dispel any smoke entering it from occupied spaces to the external space is created before entry into the staircases. Hence the passage or route through these areas (or buffer zone) which is relatively free of smoke for safe escape for the occupants and leading to the exit staircases is referred here as the smoke free approach.

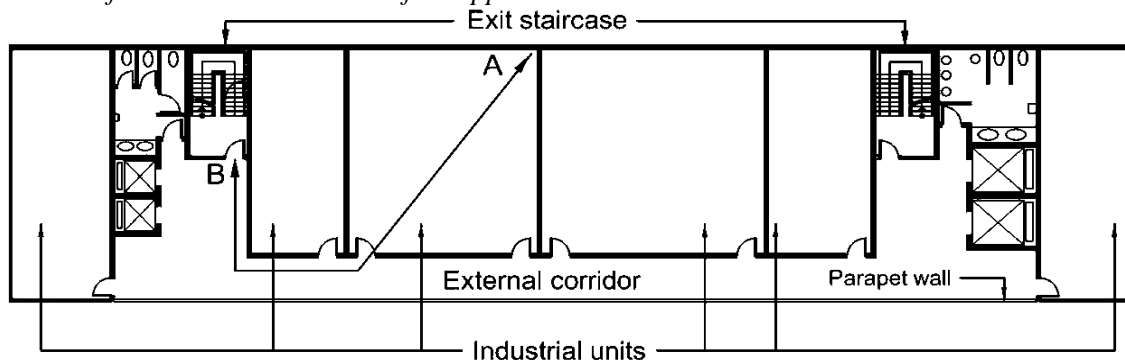

Distance AB is taken as the Travel Distance from point A

Diagram 2.2.13(a) (iii)-4

Travel Distance measurement, as shown by line AB in diagram 2.2.13 (a) (iii)-4, in the external corridor situation is taken from any remote point within the occupied area to the exit door of the exit staircase.

External Exit passageway, as shown in diagrams 2.2.13 (a) – 2 below, is a protected area, which is an extension of the vertical exit staircase. It is used to overcome excessive travel distances.

A smoke screen may be provided above the passageway before the entry into the exit staircase to prevent smoke at the ceiling level from entering the stairwell.

Approach to exit staircase through external exit passageway

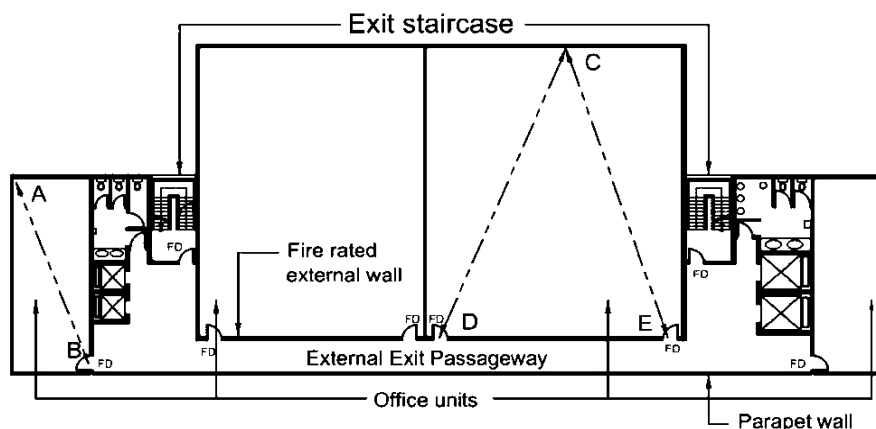

Distance AB = One-way direct distance from point A
Distance CD or CE = Two-way direct distance from point C
All doors opening to external exit passageway shall be fire rated
FD - Fire rated exit door

Diagram 2.2.13(a) (iii)-5

EXPLANATIONS & ILLUSTRATIONS

2.2.13

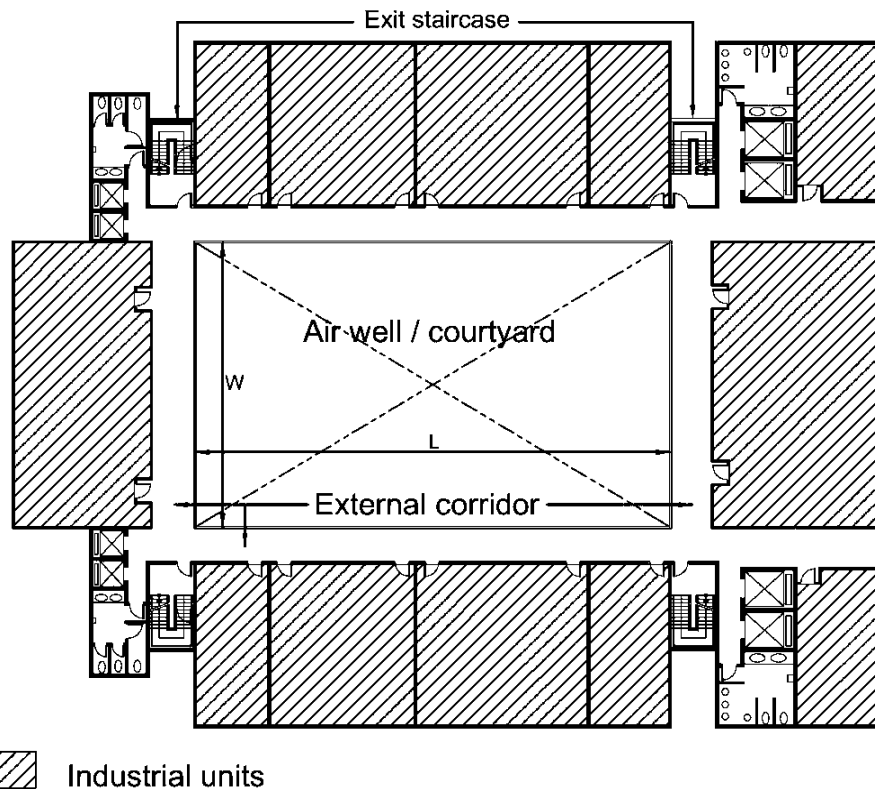

Minimum width (W or L) shall not be less than 6m.

Minimum area of air-well (W x L) shall not be less than 93m²

Diagram 2.2.13(a)(iii)-6

The height of parapet walls of corridors alongside an air-well shall not exceed 1000mm measured from its finished floor level. It shall be noted here that the ventilation openings for exit staircases in the above design layout shall not open into the air-well.



2.2.13 Smoke-stop lobby

(b) A lobby that is separated from the adjoining areas of the building by a wall having a fire resistance of 1 hour. The exit access door shall have fire resistance of half an hour fitted with automatic self-closing device conforming to the requirements of C1.3.9.2. The design of a smoke-stop lobby must be such as not to impede movement of occupants through the escape route. The floor area of a smoke-stop lobby shall be not less than 3m² and if a smoke-stop lobby also serves as a fire fighting lobby, the floor area shall be not smaller than 6m² and with no dimension smaller than 2m. The floor shall be graded from the lift door towards the lobby door with a fall not exceeding 1 in 200.

A smoke stop lobby, including fire-fighting lobby, which acts as buffer space for entry into the protected staircase and use by fire fighters during emergency, shall be maintained as common property.

EXPLANATIONS & ILLUSTRATIONS

For illustrations see clauses 1.2.34 and 1.2.58

A smoke-stop lobby shall be ventilated by:

- (i) permanent fixed ventilation openings in the external wall of the lobby; such ventilation openings shall have an area of not less than 15 per cent of the floor area of the lobby and located not more than 9m from an air-well or external recessed space of minimum clear area 93m² and minimum width of 6m. The air-well or external recessed space shall have no obstruction vertically throughout the air space for ventilation; or

EXPLANATIONS & ILLUSTRATIONS

2.2.13(b)

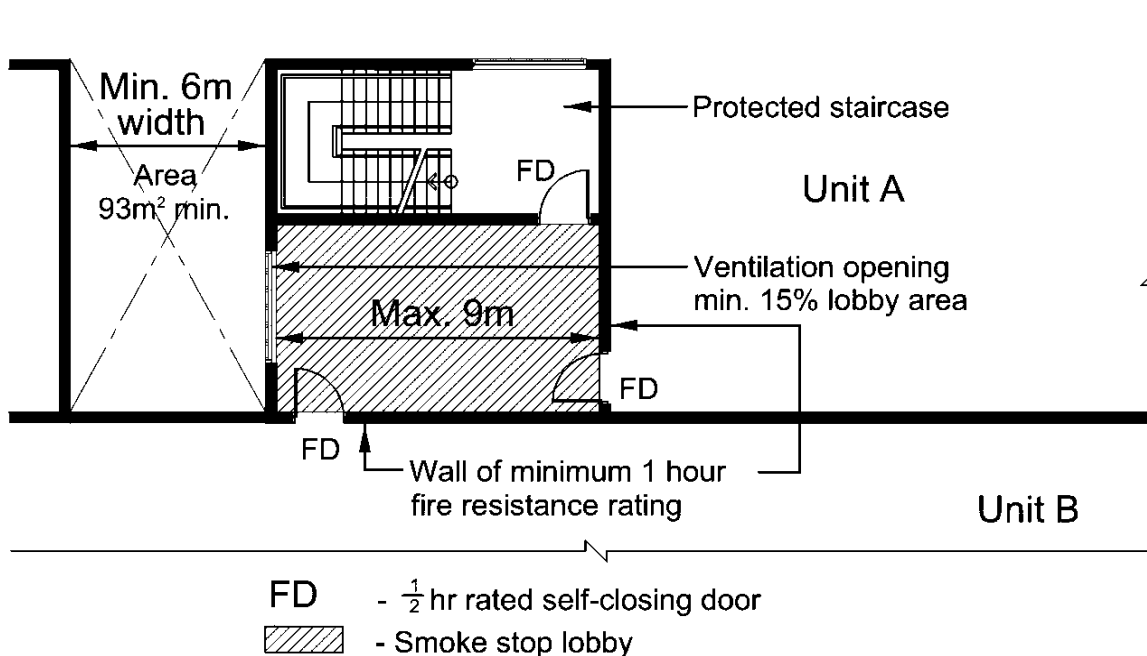

Diagram 2.2.13(b) (i)-1

To ensure that every part of the lobby is well ventilated, the distance between the external openings and any part of the lobby should not exceed 9m. In order that the smoke stop lobby can remain an effective buffer to the protected staircase, the former must be a common space, i.e. it should not be part of the apartment unit.

For effective natural ventilation, the smoke-stop lobby shall be within 9m of its ventilation openings. To ensure the integrity of smoke-stop lobby as dedicated buffers protecting exit staircase from smoke infiltration, it must be located in natural spaces. This arrangement would prevent any misuse by tenants, as the case may be if the lobby is to be located within a privately owned space.

EXPLANATIONS & ILLUSTRATIONS

2.2.13(b)

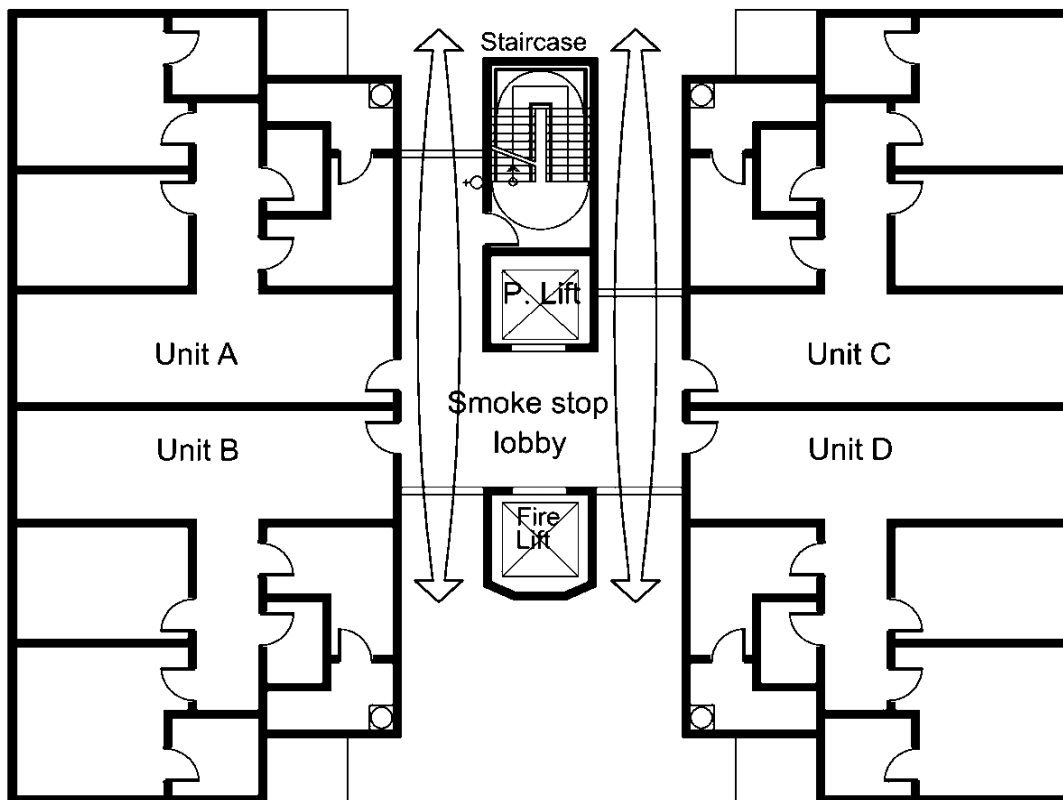
*Diagram 2.2.13(b) (i)-2*

For high-rise residential blocks with single exit staircase, the approach to the exit staircase is through a cross-ventilated lobby. See Cl.2.4.5 (f) for details the provision of openings to the lobby.

To comply with the provision of single exit staircase, designer has to make reference to Cl. 2.4.5 of current Fire Code.



(ii) mechanical ventilation, except for purpose Group II, complying with the requirements in Chapter 7, or

EXPLANATIONS & ILLUSTRATIONS

2.2.13(b)

For buildings under Purpose Group II, smoke free approach to exit staircase shall be provided with natural ventilation and lighting. In the case of Purpose Group III to VIII, smoke free approach to exit staircase, the need to provide mechanical ventilation would be considered if the lobby is internal where provision of natural lighting/ventilation is not possible.

Mechanically Ventilated Smoke Stop Lobby

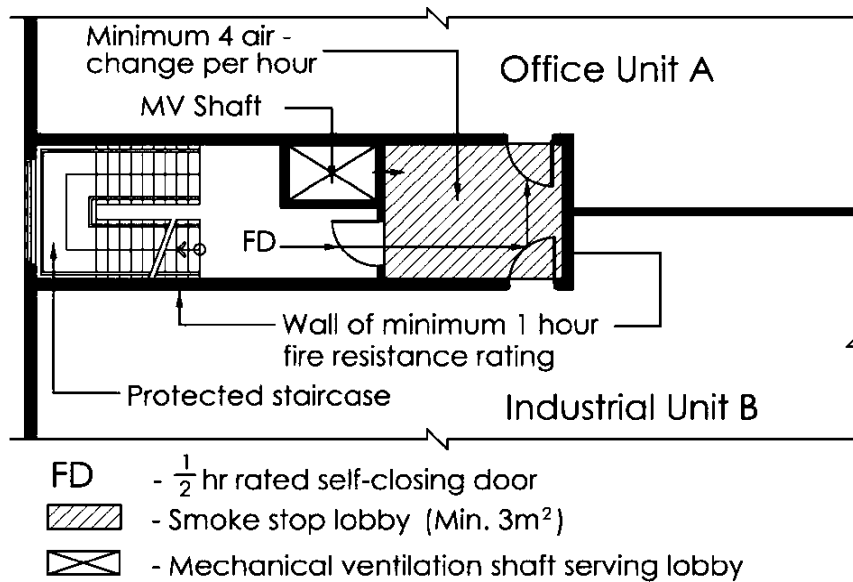

Diagram 2.2.13(b) (ii)



(iii) permanently fixed ventilation openings of area not less than 15 percent of the floor area of the lobby and located not more than 9m from any part of the lobby, opening to an open air well which is open vertically to the sky for its full height. The air-well size shall be in accordance with Cl.2.2.13(a)(iii) except for building not more than 4-storey, in which the air-well shall have a horizontal plan area of not less than 10m² or 0.1m² for each 300mm of height of the building, whichever is the greater. The minimum width of such air-well space shall not be less than 3000mm. The enclosure walls to the air well shall have a minimum fire resistance of 1 hour and have no openings other than ventilation openings for the smoke-stop lobby, exit staircase and toilets, or

EXPLANATIONS & ILLUSTRATIONS

2.2.13(b)

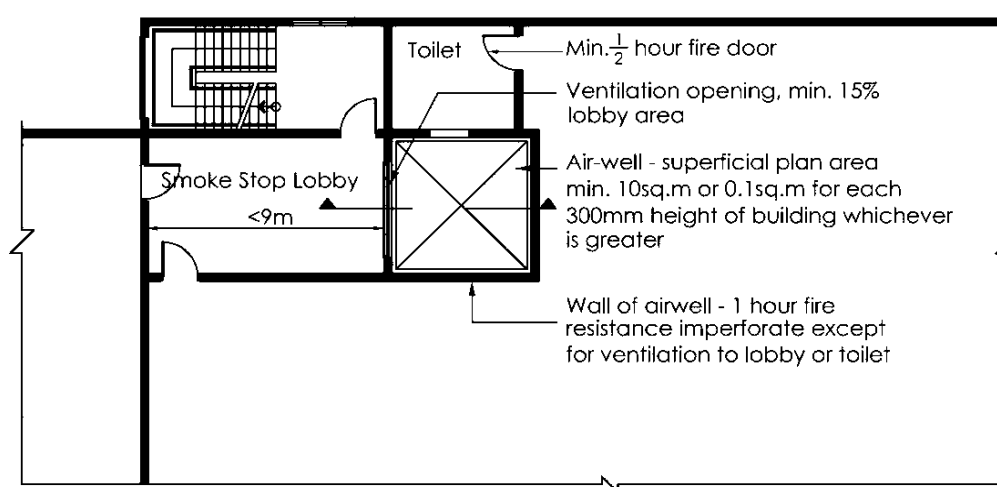

Plan

Diagram 2.2.13(b) (iii)-1



EXPLANATIONS & ILLUSTRATIONS

2.2.13(b)

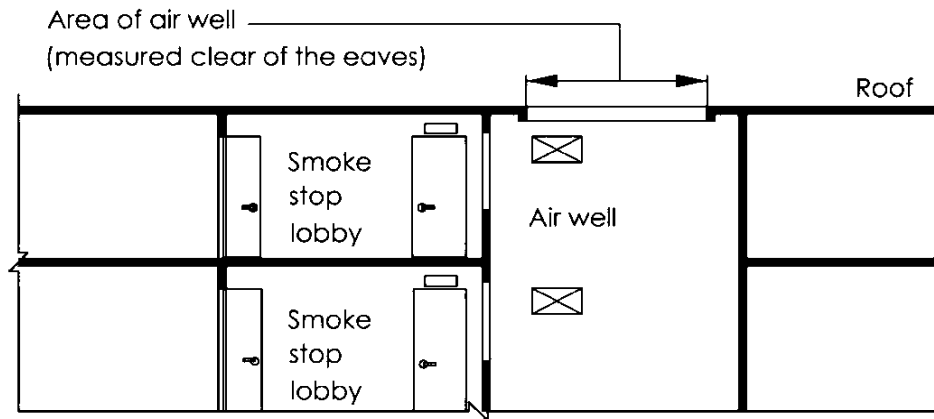

Sectional view

Diagram 2.2.13(b) (iii)-2

The provision of air well to ventilate the internal smoke-stop lobby as shown above is an alternative to mechanical ventilation. This provision is a relaxation to allow toilets, considered as wet areas having low fire risk, to ventilate into such air wells. The doors to the toilets shall have min. ½ hour fire resistance rating. The whole area of the air well throughout its entire height shall be maintained fully open to the sky at all times.

(iv) cross-ventilated corridor having fixed ventilation openings in at least two external walls. The openings to each part of the external walls shall not be less than 50 per cent of the superficial area of the opposing external wall. No part of the floor area of the corridor shall be at a distance of more than 13m from any ventilation openings.

EXPLANATIONS & ILLUSTRATIONS

2.2.13(b)

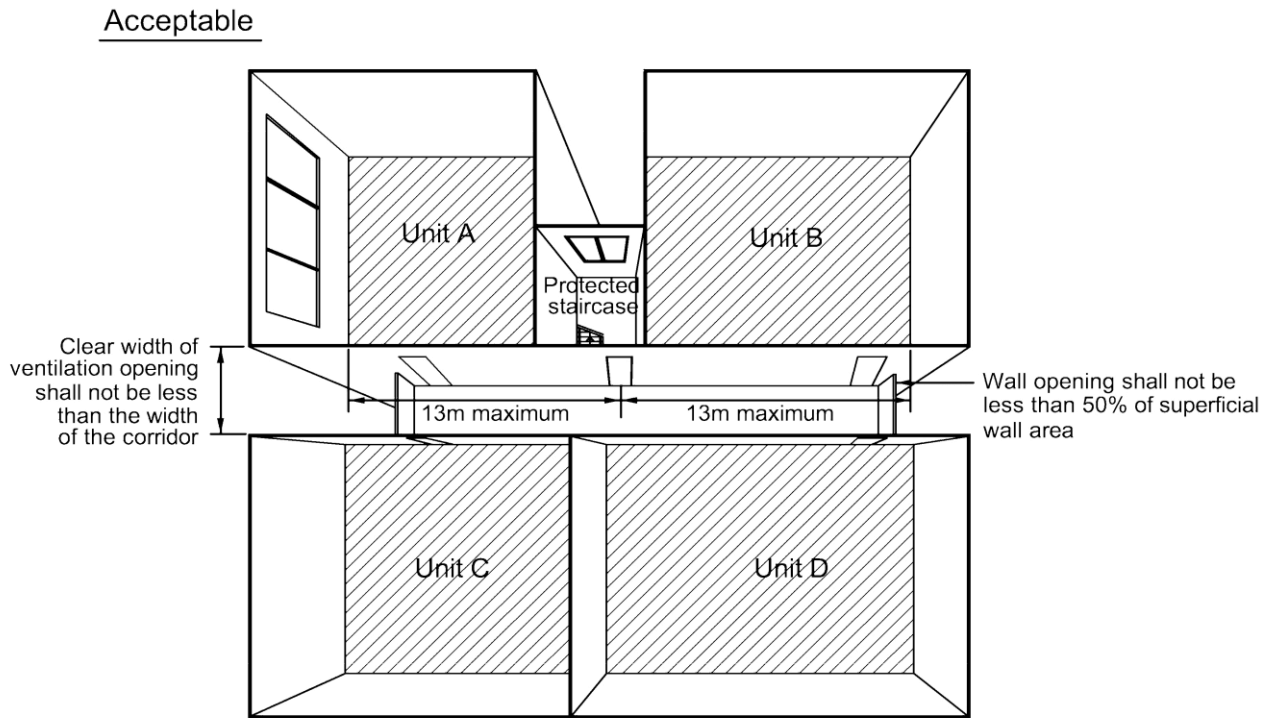

Diagram 2.2.13(b) (iv)-1

For the purpose of measuring the horizontal distance of max. 13m from any floor space of the corridor to the ventilation openings, the ventilation openings shall be assumed to be located at the edge of the building and not at the edge of the corridor.

It is important to note that the above requirements shall not be taken to equal other clauses that call for smoke free approach and cross ventilated lobby approach under Cl.2.4.5(f).



EXPLANATIONS & ILLUSTRATIONS

2.2.13(b)(iv)

Acceptable layout

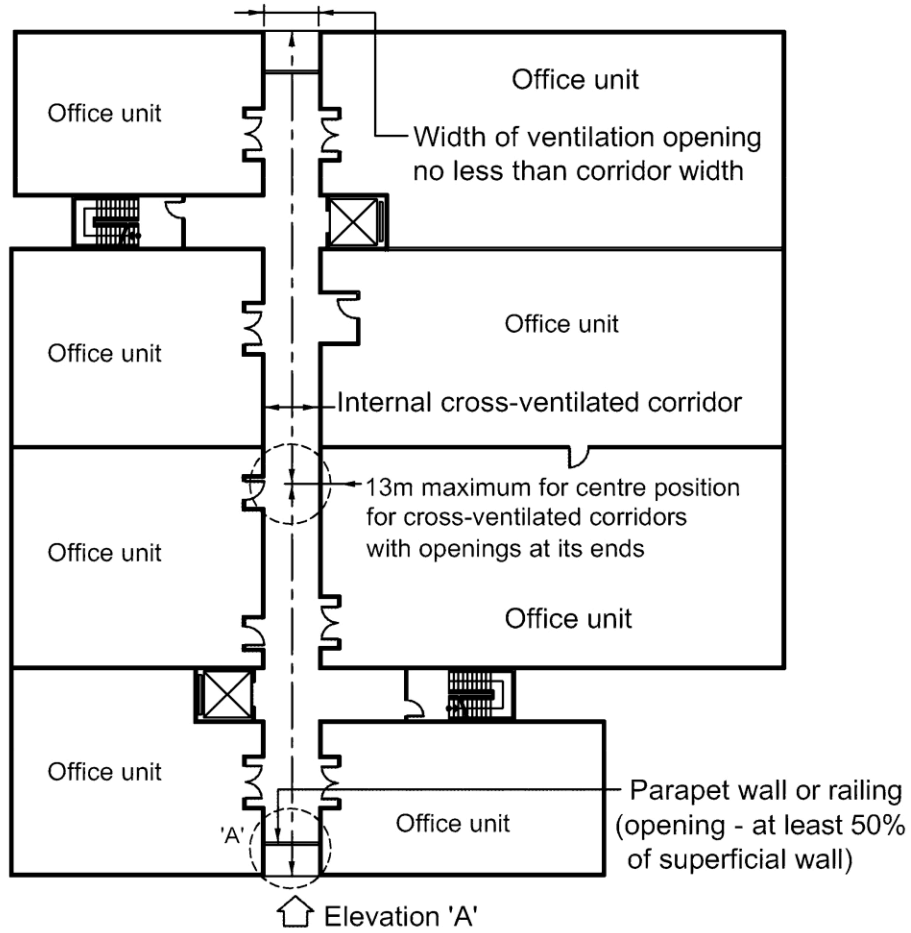

Diagram 2.2.13(b) (iv)-2

EXPLANATIONS & ILLUSTRATIONS

2.2.13(b)(iv)

Not acceptable layout

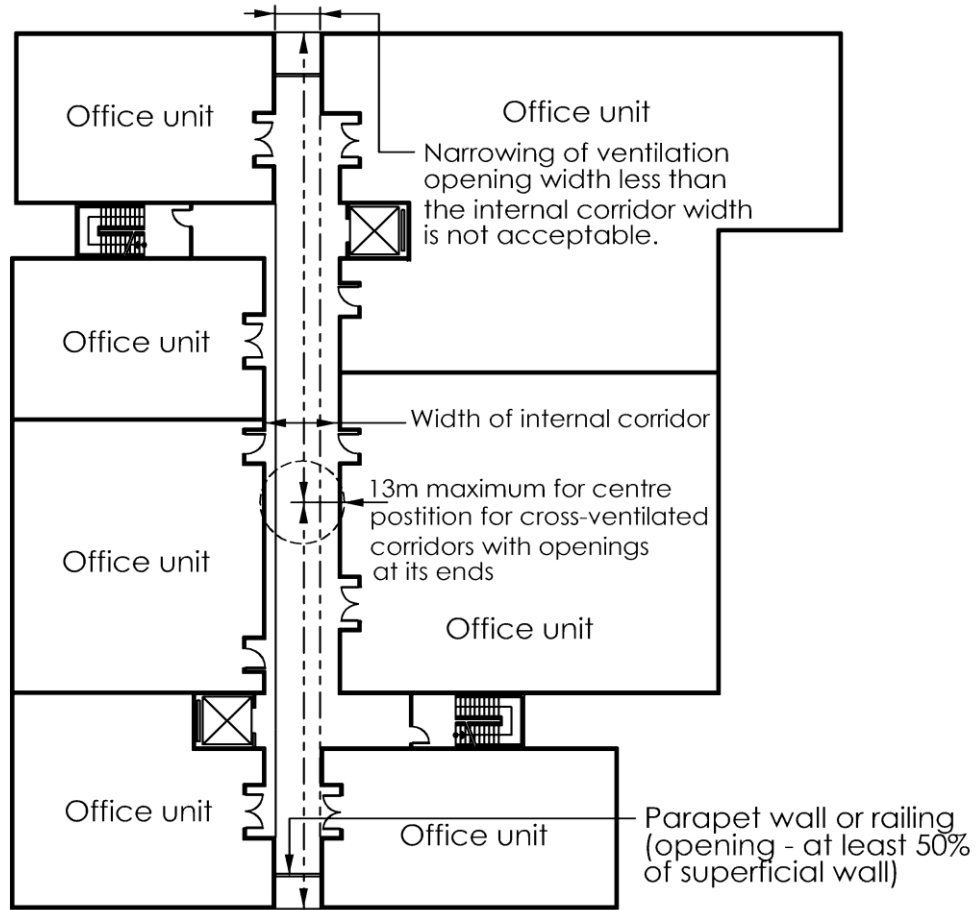

Diagram 2.2.13(b) (iv)-3

The above provision of cross-ventilated corridor is not acceptable, as the ventilation opening on one side of the building is narrower than the width of the corridor. This could adversely affect the movement of air currents through the corridor, intended to draw out any smoke in the corridor area before it can affect the staircase.



EXPLANATIONS & ILLUSTRATIONS

2.2.13(b) (iv)

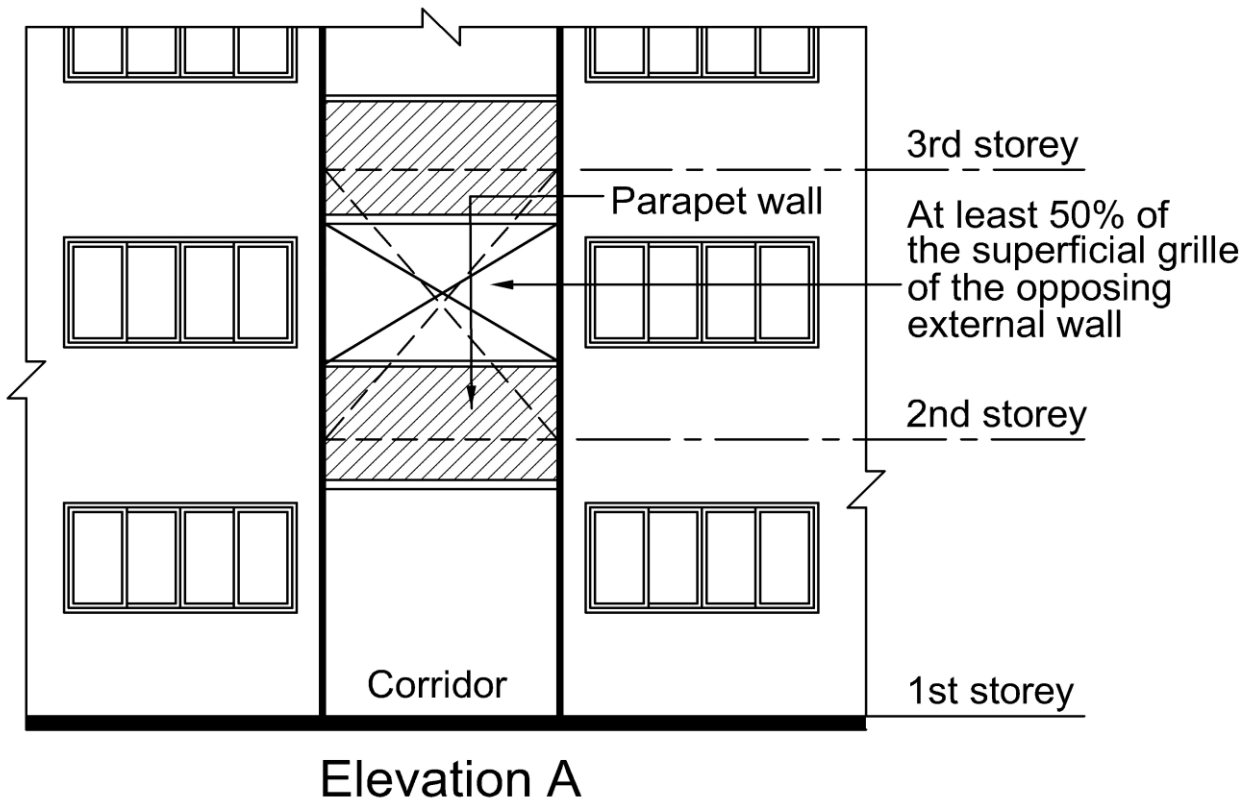

Diagram 2.2.13(b)(iv)-4



2.2.13 Omission of smoke-stop lobby is allowed

(c) Exception:

- (i) The omission of smoke stop lobby required under Cl.2.2.13(b) to exit staircase of any building exceeding 4 storeys is allowed under the following situations, provided the door opening into the exit staircases shall be at least 1-hour fire resistance and fitted with automatic self-closing device to comply with the requirements of Cl.3.9.2:
 - (1) where the internal exit staircase is provided with pressurization up to a habitable height of 24m in compliance with the requirements of Chapter 7;
 - (2) where an external exit staircase is constructed to comply with Cl.1.2.29;
 - (3) where an external exit staircase of a building is located along its perimeter wall and provided with uninterrupted external ventilation openings having not less than 50% of the planal area of the staircase at each storey level;
 - (4) in an open-sided car park floor where cross-ventilation is provided. Under this situation, the fire door to the exit staircase can be ½-hour fire rated.

EXPLANATIONS & ILLUSTRATIONS

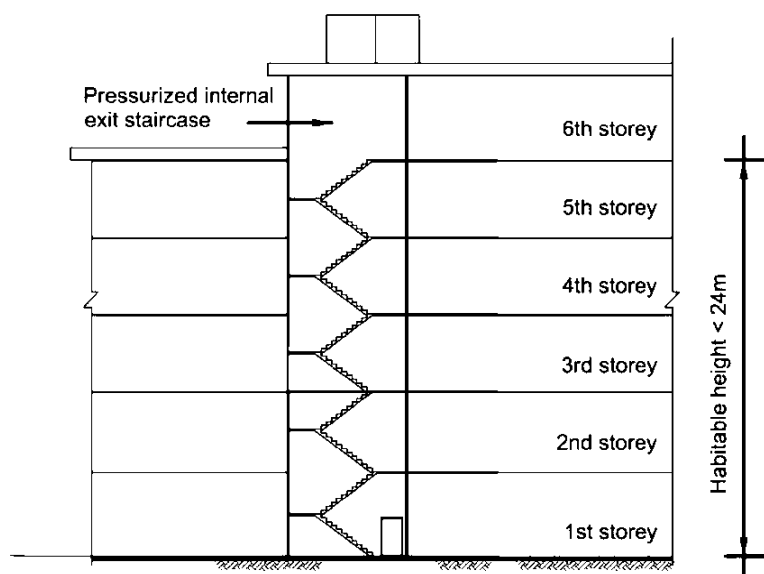

Diagram 2.2.13(c) (i) (1) & 2.2.13(c) (ii).

Any internal exit staircase with dedicated pressurization system (without natural ventilation) and its height not exceeding 24m will be permitted without the provision of smoke stop lobby. The door opening into the staircase is required to have minimum 1-hour fire resistance rating

The above smoke stop lobby exemption is not applicable to fire-fighting staircase and buildings under Purpose Group III & VII.



EXPLANATIONS & ILLUSTRATIONS

2.2.13(c) (i)(3)

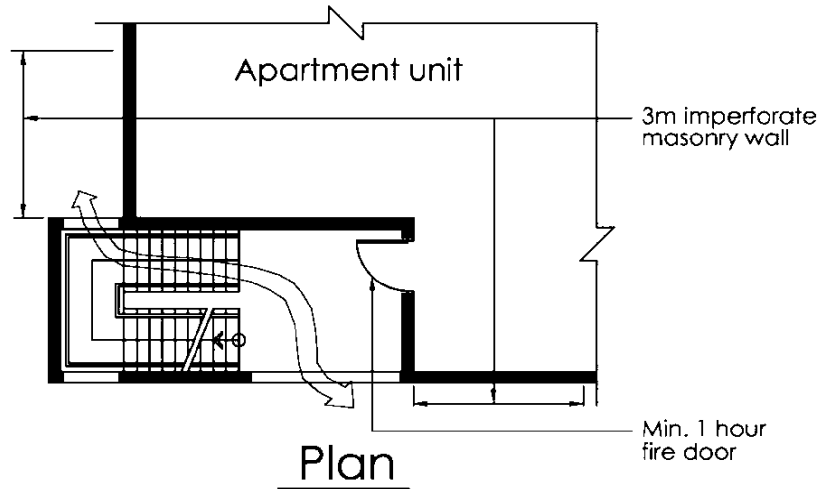

Diagram 2.2.13(c) (i)(3) & 2.2.13(c)(ii)

Smoke stop lobby is exempted if an external exit staircase located along the perimeter wall of the building is required to be cross-ventilated having uninterrupted external openings of minimum 50% of the planal area of the staircase

The above smoke stop lobby exemption is not applicable to fire-fighting staircase and buildings under Purpose Group III & VII.

(ii) The omission of smoke stop lobby to exit staircases shall not be allowed under the following situations : -

- (1) where the building exceeds 4 storeys and belongs to Purpose Group III and VII;
- (2) where the internal exit staircase, which is provided with pressurization, exceeds the habitable height of 24m;
- (3) where the exit staircase is designated as fire-fighting staircase adjacent to a fire lift as required in Chapter 6.

EXPLANATIONS & ILLUSTRATIONS
2.2.13(c)(ii)

The door opening into:

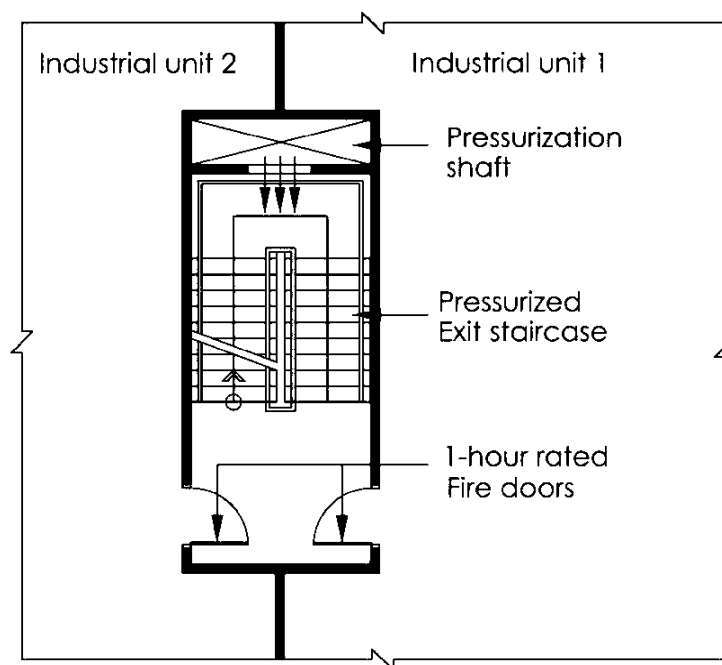

Diagram 2.2.13(c)(ii)-1

The positive pressure in the pressurized staircase diagram 2.2.13 (c) (ii) - 1 acts to force smoke away from the doorway of the staircase when that exit door is opened, thereby preventing smoke entry into the staircase. The above exemption shall apply to building of which the habitable height does not exceed 24m. This is to meet the requirements under Cl.2.3.3 (g) and Cl.7.2.1 (a) which specifically require all internal staircases of building having a habitable height exceeding 24m to be pressurised. If the habitable height of the building exceeds 24m, the entry to the internal exit staircase shall be through smoke-stop lobby or external approach.

EXPLANATIONS & ILLUSTRATIONS

2.2.13(c)(ii)

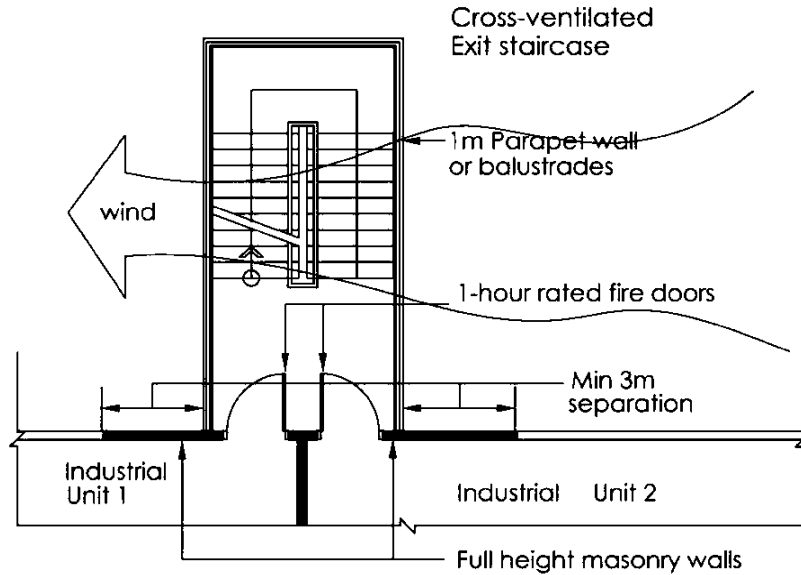

Diagram 2.2.13(c)(ii)-2

In the case of the cross-ventilated staircase (diagram 2.2.13 (c) (ii)-2), its open sides allow for quick dispersal of any smoke infiltrating the doorway when opened.

Hence, in both these situations, it is possible to achieve a relatively safe smoke free environment in the exit staircase for facilitating escape for its occupants. Another reason to note is that these premises warrant emergency plans and fire drills to familiarize its occupants on their procedural actions in fire emergencies.

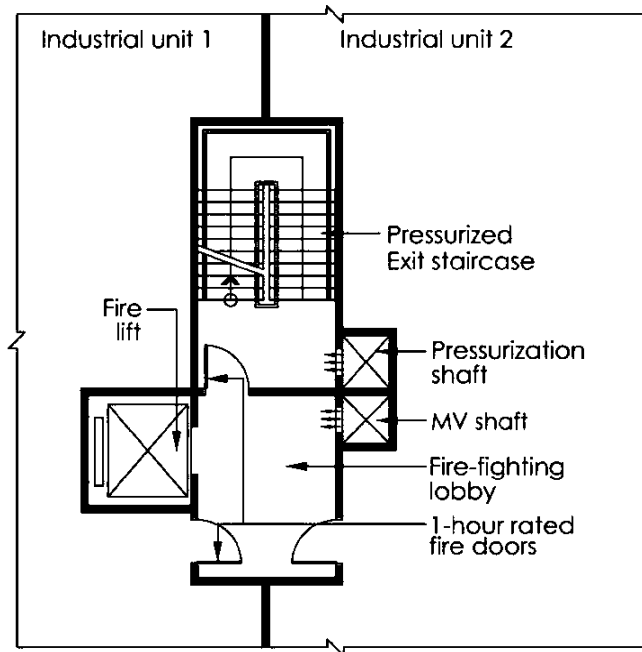
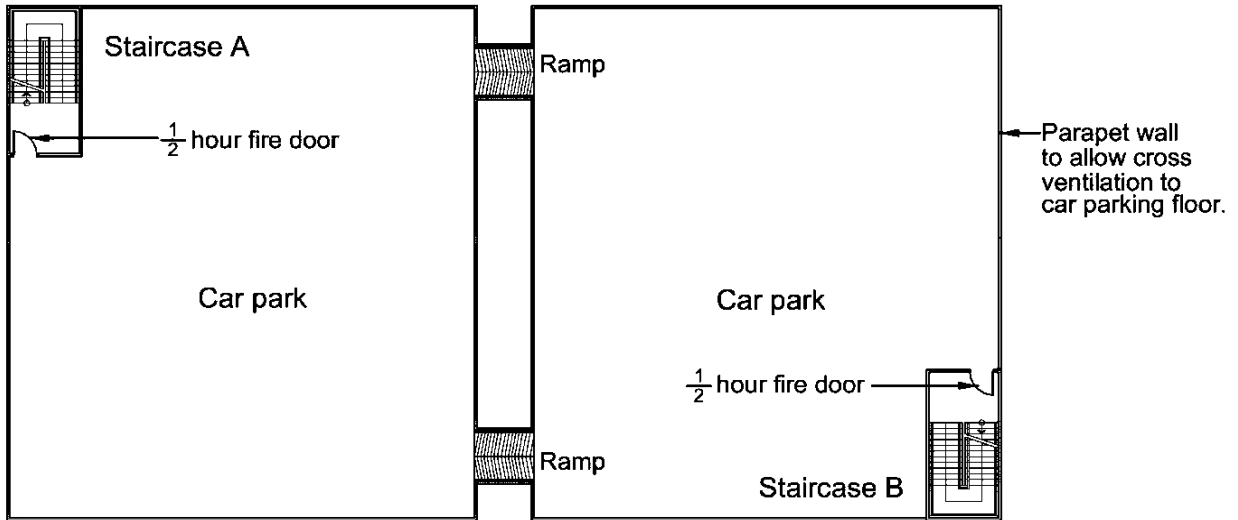

Diagram 2.2.13(c)(ii)-3

EXPLANATIONS & ILLUSTRATIONS

2.2.13(c)(ii)



Plan

Diagram 2.2.13(c)(ii)-4

Open-sided multi-storey car park

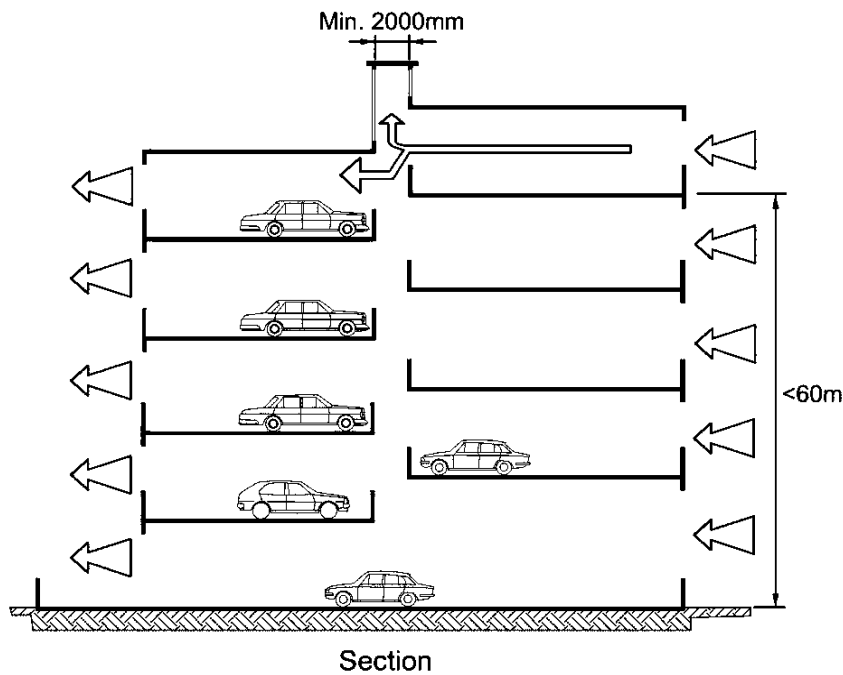

Section

Diagram 2.2.13(c) (ii)-5

The above requirement exempts the provision of smoke stop lobby to exit staircases in cross-ventilated car park buildings. In diagram 2.2.13(c) (ii)-4, the space before the exit staircases can satisfactorily achieve a smoke free environment. The doors to exit staircases shall be min. $\frac{1}{2}$ -hour fire rated.

EXPLANATIONS & ILLUSTRATIONS

2.2.13(c)(ii)

Situation where no exemption is granted: -

Internal staircase serving building exceeding 24m habitable height

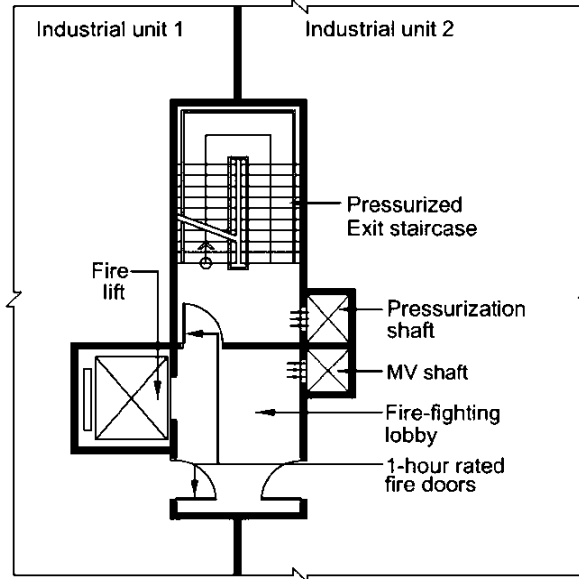

Diagram 2.2.13(c)(ii)-6

Situation where no exemption is granted: -

When adjacent to fire lift

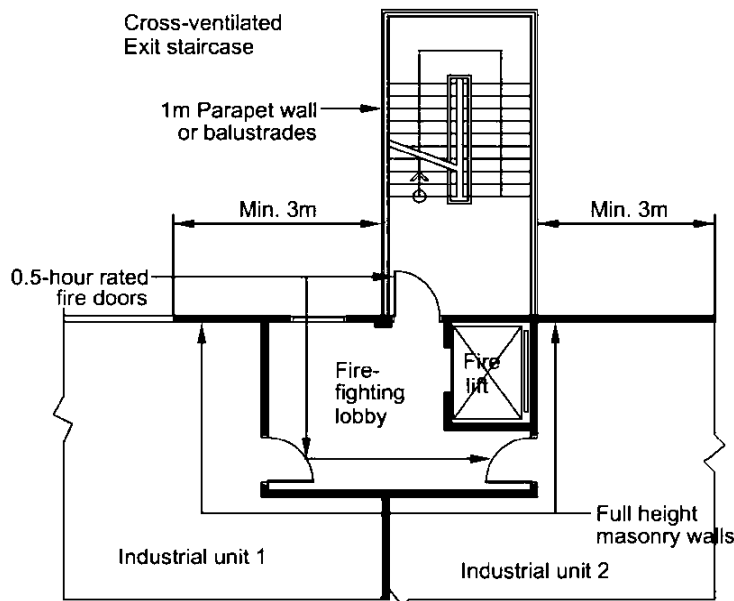

Diagram 2.2.13(c)(ii)-7

No exemption of the smoke stop lobby will be granted for such exit staircases if it is a fire-fighting staircase adjacent to a fire lift. The fire fighters would require the lobby space as a ‘staging’ point in their fire fighting operations, prior to entering into the affected areas, in fire emergencies.

EXPLANATIONS & ILLUSTRATIONS

2.2.13(c)(ii)

(Note: Cl 2.2.13(c) (ii) (b) is not applicable to buildings under purpose group VII)

Smoke stop lobby is exempted for the arrangements shown in diagrams 2.2.13 (c) (ii) – 1 & 2 in building of Purpose Groups II, IV, V, VI & VIII up to 60m high. The reasons for this relaxation being:

Any internal exit staircase without provision for natural ventilation and in habitable height not exceeding 60m will be provided with dedicated pressurization system. The door opening into the staircase is required to have minimum 1-hour fire resistance rating.

Partially enclosed staircase is required to be cross-ventilated having uninterrupted external openings of minimum 50% of the plan area of the staircase.

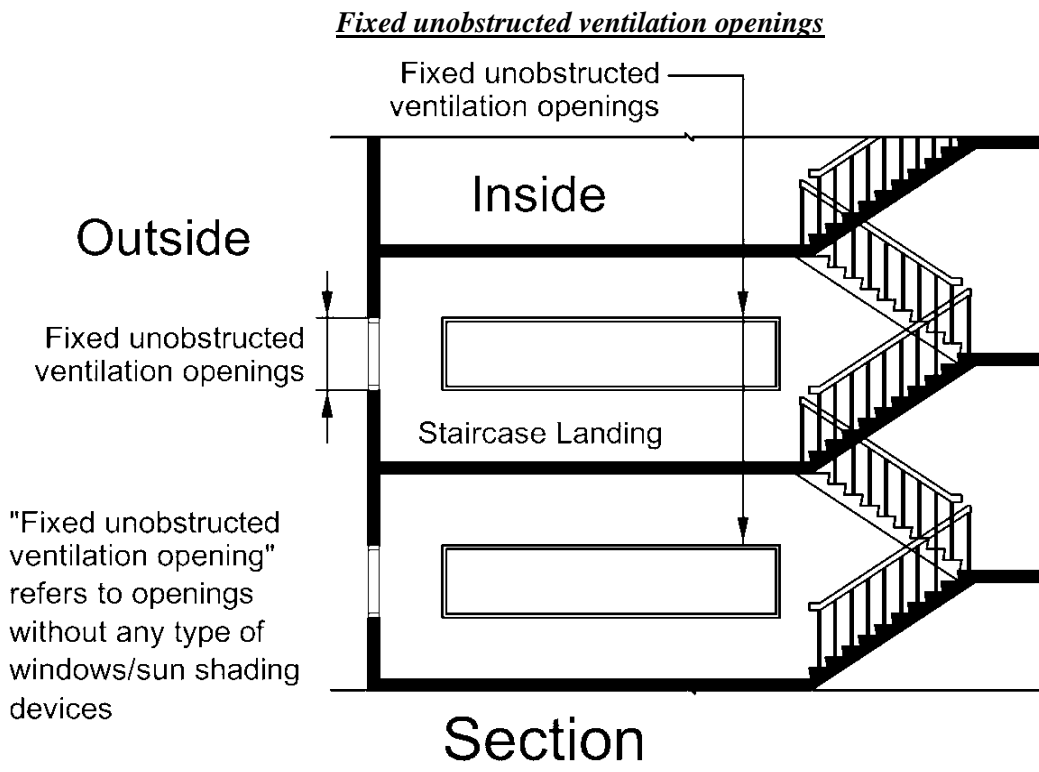

Diagram 2.2.13(c)(ii)-8

EXPLANATIONS & ILLUSTRATIONS

2.2.13(c)(ii)

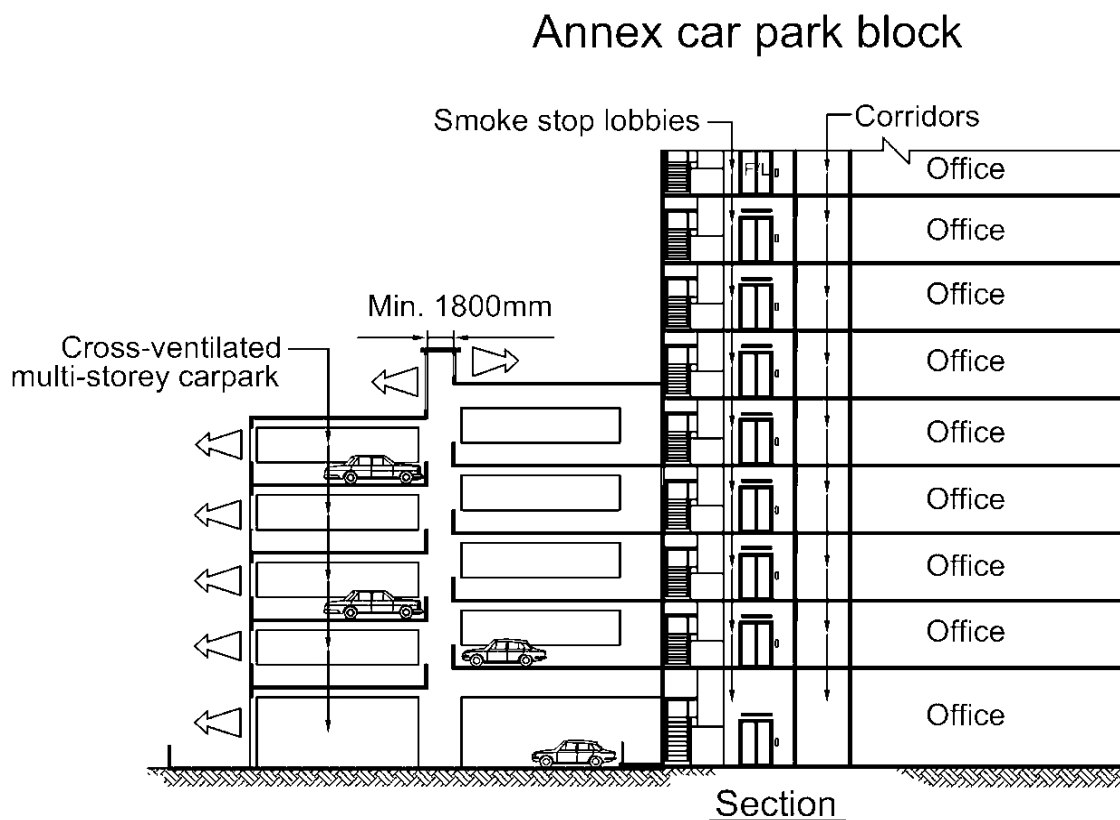

Diagram 2.2.13(c) (ii)-9

Likewise a cross-ventilated car parking storey in diagram 2.2.13(c) (ii) - 9 is exempted from the provision of smoke stop lobby to exit staircase. However, the upper storeys above the car parking floors are not exempted from provision of Cl.2.2.13(c) (ii).

CHAPTER 2

2.2 DETERMINATION OF EXTI REQUIREMENTS

2.2.14 Smoke free approach in basement

Smoke Free Approach to Exit Staircase in Basement Occupancy:

- (a) In a building comprising more than 4 basement storeys, entry to exit staircases serving the basement storeys at every basement storey level shall be through smoke-stop lobbies, one of which shall be designated as fire-fighting lobby. The exit staircase connecting to the fire-fighting lobby shall be pressurised to comply with the requirements in Chapter 7, and

EXPLANATIONS & ILLUSTRATIONS

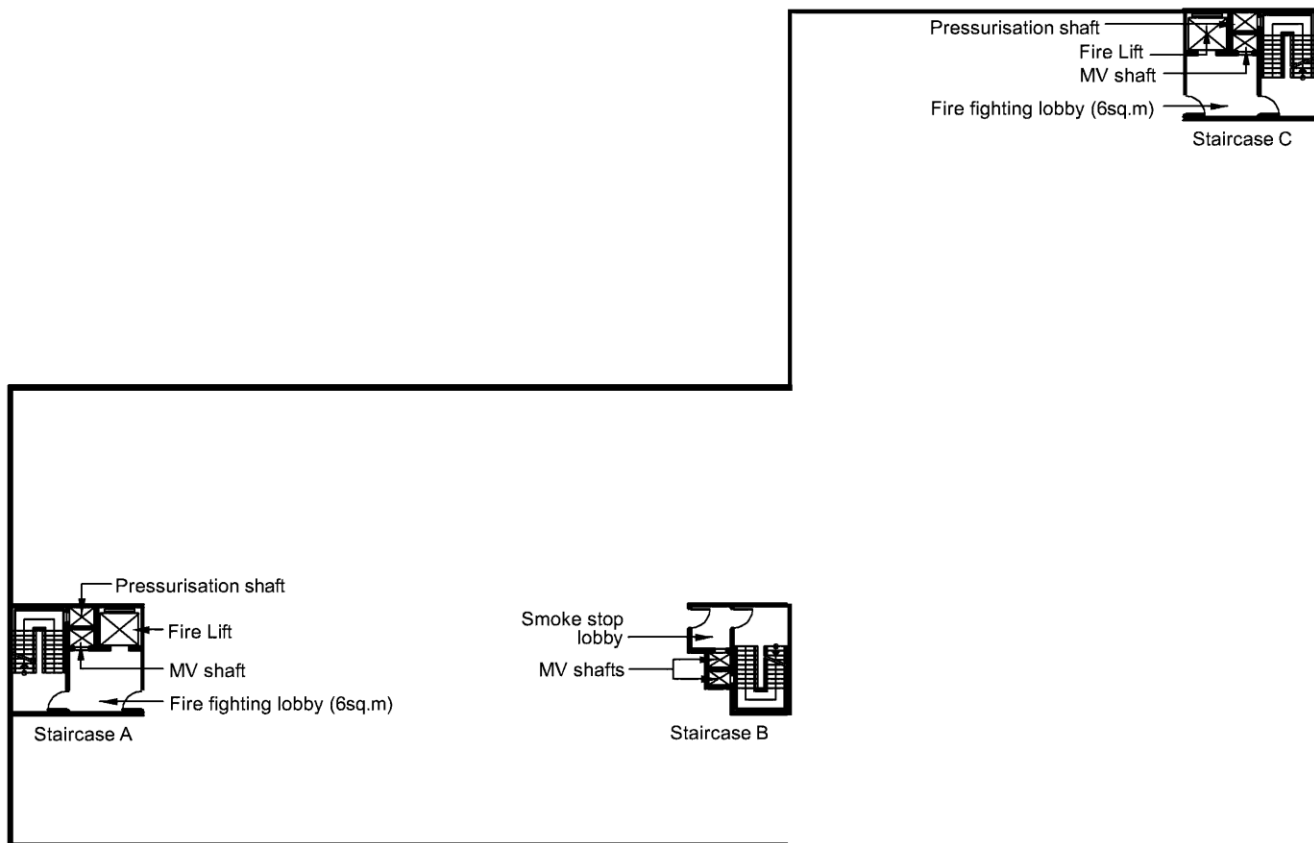

Typical Basement Plan (> 4 basement storey)

Diagram 2.2.14(a)

Smoke-stop lobby is required for all staircases, one of which shall be designated as a fire-fighting lobby. Owing to the depth of the basement, and to prevent heat and smoke from getting into the staircase, the provision of smoke-stop lobby is required. This is similar to the requirement of smoke-stop lobby to building exceeding 4 storeys above ground. Also refer to clause 6.6.3(a) for the provision of two fire lifts if basement depth exceeds 9m.



(b) In a building comprising 2, 3 or 4 basement storeys, entry at every basement storey level to at least one of the exit staircases serving the basement storeys shall be through a smoke-stop lobby and where only one smoke-stop lobby is provided, it shall be required to serve as a fire-fighting lobby, and

EXPLANATIONS & ILLUSTRATIONS

2.2.14

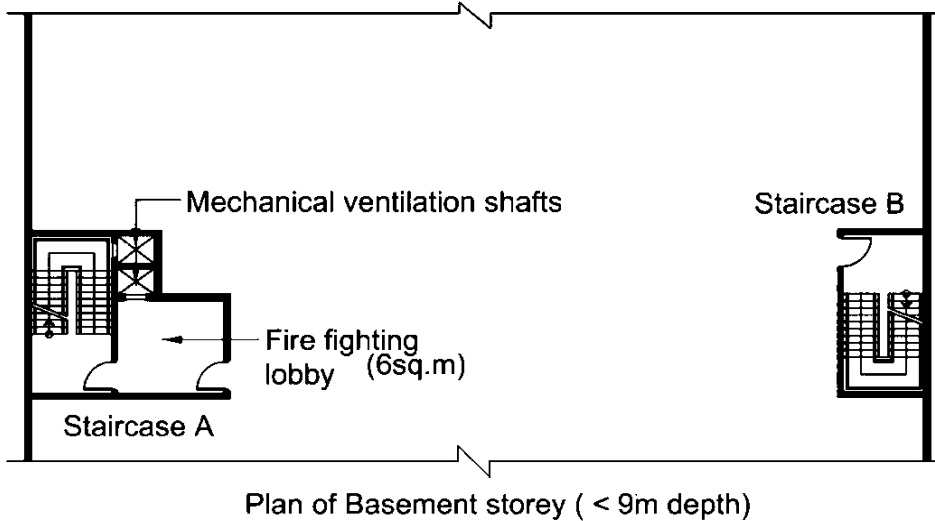

Diagram 2.2.14(b)-1

Smoke-stop lobby is required for at least one of the staircases. One of which shall be designated as a fire-fighting lobby.

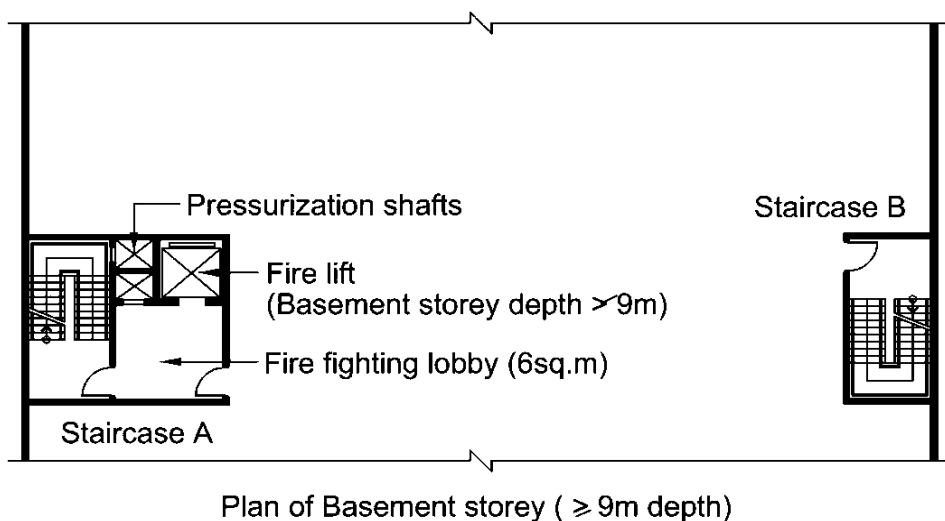

Diagram 2.2.14(b)-2

At least one staircase requires smoke-stop lobby, which shall also be served as fire-fighting lobby. Also refer to clause 6.6.3(a) & (b) which requires two fire lifts and fire-fighting staircase to be provided.



(c) Smoke-stop lobbies in basement occupancies shall be required to comply with the relevant provisions under C1.2.2.13 (b) and shall be mechanically ventilated to comply with the requirements in Chapter 7.

EXPLANATIONS & ILLUSTRATIONS

2.2.14(c)

No Illustration. Please refer to Chapter 7.



CHAPTER 2

2.2 DETERMINATION OF EXIT REQUIREMENTS

2.2.15 Area of refuge and exit reduction

When a floor area has access to Area of Refuge in compliance with following requirements in this Clause, the occupant load for which vertical exits are to be accounted for the floor area may be reduced to half when one Area of Refuge is provided and to one-third when two or more Areas of Refuge are provided.

- (a) Area of Refuge shall be :
 - (i) Adequate in size to hold the occupant load it receives from the floor area it serves as provision for required exit, in addition to its own occupant load calculated on the basis of 0.3 m² per person except for Health Care Occupancies when the occupant load shall comply with the provisions under Cl.2.5.3 , and
 - (ii) Provided with at least one staircase for use by the occupants to gain access to other exit staircases or the ground level directly to an exterior open space; and
- (b) An Area of Refuge shall be entered through an external corridor and the room or space or Area of Refuge shall be separated from the corridor by a wall with minimum 1 hour fire resistance, and
- (c) External corridors when used as entry into an Area of Refuge shall conform to the requirements of external exit passageway for minimum width, changes in floor level, roof protection, enclosure on the open side and provision of opening of wall between the room or space and the exit passageway, and
- (d) Exit doors between the room or space or Area of Refuge and the external corridor shall have fire resistance of at least half an hour and fitted with automatic self-closing device to comply with the requirements of Cl.3.9.2, and
- (e) Every fire compartment in which exit reduction is permitted in connection with Area of Refuge shall have in addition to exit through the Area(s) of Refuge at least one staircase complying with Cl.2.3.3.

EXPLANATIONS & ILLUSTRATIONS

An area of refuge is intended to provide only temporary point of safety to permit delayed egress travel from any level. Therefore, an area of refuge cannot be a room or space whose only access to the building spaces is through the space where the fire is located has been provided. Rather, the area of refuge must provide access to a public way via an exit such as an enclosed exit stair.

See cl. 1.2.4 and sub-cl. 2.2.6(f) for illustration.



CHAPTER 2

2.3 MEANS OF ESCAPE REQUIREMENTS

2.3.1 General	
<p>(a) Means of escape shall be provided for all buildings by one or more of the facilities listed herein. Access and exit facilities not specifically covered in this Code shall not be used without the approval of the MFRS. Required exits shall be kept readily accessible, and doors shall be openable and unobstructed at all times during the occupancy of the building.</p> <p>(b) Staircases serving all buildings (except Purpose Group I) shall be provided with a signage not smaller than 300 x 300mm and within the stairwell at each storey landing.</p> <ul style="list-style-type: none"> (i) The storey number, at least 125mm in height (ii) An identification of the staircase in alphabetical and/or numeric, at least 25mm in height. (iii) The signage shall be located such that it is visible when the door is in the open position and also visible to any person moving up or down the staircase. (iv) The letters and numbers on the sign may be of any colour that shall contrast with the background colour. 	
EXPLANATIONS & ILLUSTRATIONS	
<p><u>Staircase Identification</u></p> <p><i>Staircase identification is required for all buildings (except Purpose Group 1) irrespective of the height of the building.</i></p> <p><i>Staircase identification is to facilitate fire-fighting operation. It also enables the user of the staircase to orientate his location or whereabouts. This would help to alleviate any fear of disorientation by a person using the staircase during a fire emergency.</i></p> <p><u>Requirement on Stairway numbering system</u></p> <ul style="list-style-type: none"> (a) <i>The numbering system is composed of square signs of at least 30cm x 30cm located, or painted, on the wall surface adjacent to the door on the stairway side.</i> (b) <i>A sign should be located at each level landing in the stairway. The bottom of the sign should be located not less than 1.5m above the floor of the staircase landing. The sign should be placed adjacent to the door and shall be visible with the door opened or closed.</i> 	

EXPLANATIONS & ILLUSTRATIONS

2.3.1

- (c) The block-lettered sign may be of any colour that will contrast with the colour scheme of the stairway.
- (1) The height of the large number(s) in the middle of the sign denoting the storey should be a minimum of 12.5cm.

Location of sign in staircase

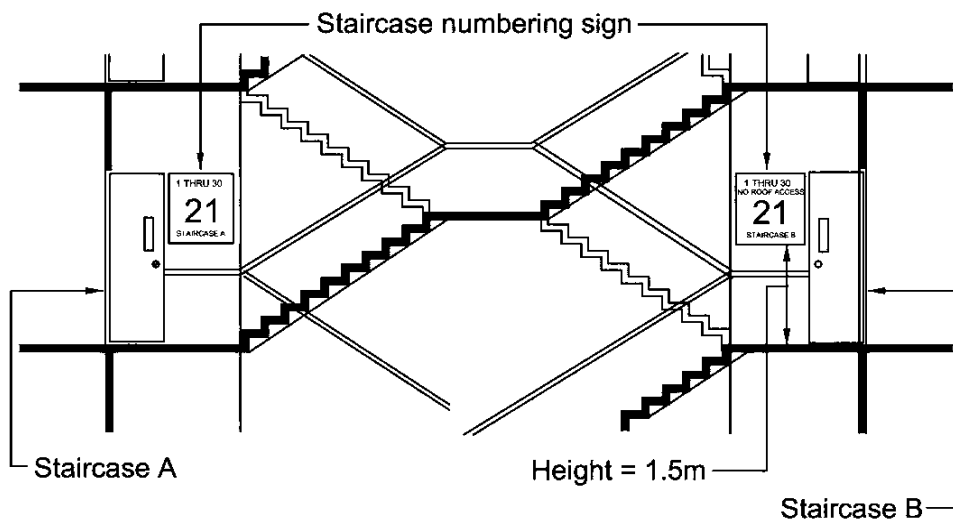

Scissor exit staircases

Diagram 2.3.1(b)-1

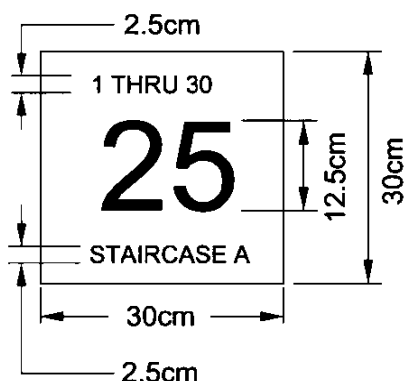

EXAMPLE 1

25th storey of a staircase that extends from the 1st storey to the 30th storey of a 30-storey building. The stairway terminates at the roof. This is the 'A' Staircase in the building.

Diagram 2.3.1(b)-2

- (2) The number(s) and/or letter(s) at the top of the sign denoting the upper and lower terminations of the stairway should be a minimum of 2.5cm.

Identification of staircases in the building should be indicated in alphabetical and/or numeric order. The lettering height should be 2.5cm minimum, e.g., Staircase A, and located at the bottom of the sign.

EXPLANATIONS & ILLUSTRATIONS

2.3.1

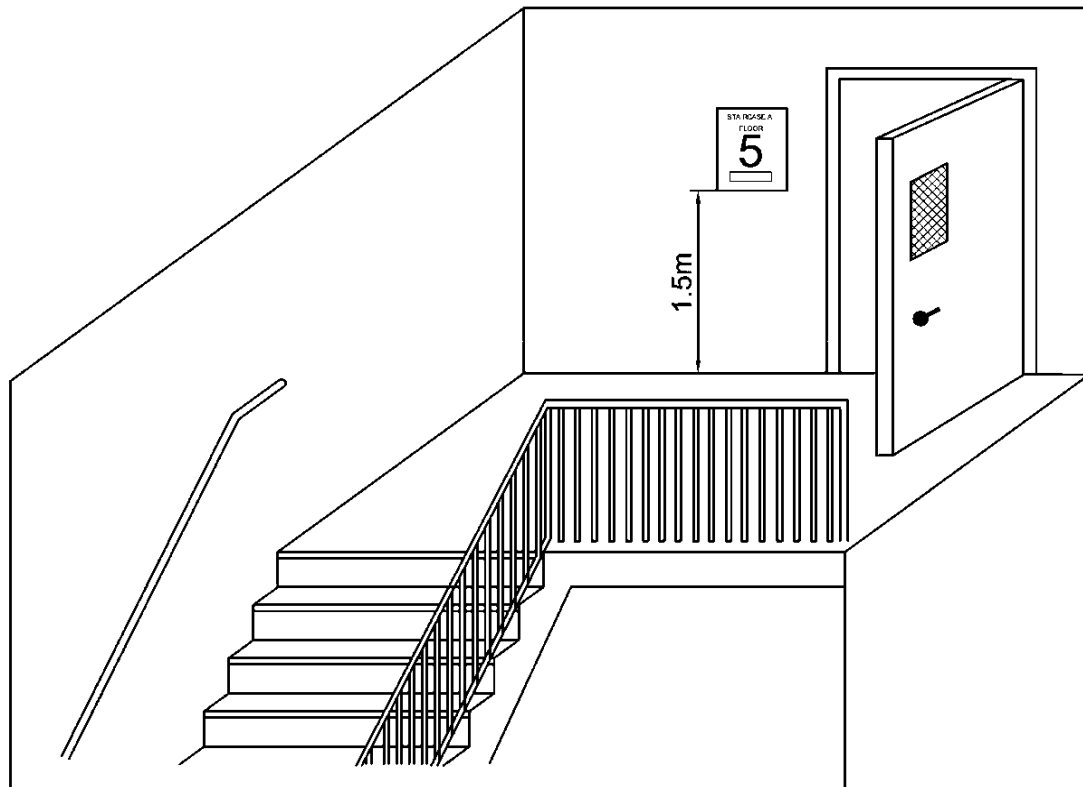

Diagram 2.3.1(b)-3

The intent of this provision is to provide vital egress information to the occupants of a building and to fire fighters. To reduce information overload to occupants during emergency egress, a sign indicating the floor level and the direction to the exit discharge is permitted to be placed as a separate sign with another sign indicating the floor level, the terminus of the top and bottom of the stair enclosure, and the identification of the stair.



CHAPTER 2

2.3 MEANS OF ESCAPE REQUIREMENTS-GENERAL

2.3.2 Exit passageways

(a) Fire resistance

Exit passageways that serve as a means of escape or required exits from any building or storey of a building shall have the requisite fire resistance as specified under Cl.3.3.

EXPLANATIONS & ILLUSTRATIONS

No illustration. Generally exit passageways can be internal exit passageway or external exit passageway. It is intended as an extension of exit staircase. Please refer to Cl.3.3 for details.



(b) Internal exit passageway

- (i) an internal exit passageway which serves as required exit of the building shall be enclosed with construction complying with the provisions of Cl.3.3, and
- (ii) the enclosure walls of an exit passageway shall have not more than two exit doors opening into the exit passageway, and
- (iii) exit doors opening into an exit passageway shall have fire resistance rating as required for exit doors opening into exit staircases, fitted with automatic self-closing device and complying with the requirements of Cl.3.9.2 for fire resisting doors, and
- (iv) the minimum width and capacity of exit passageway shall comply with the requirements as provided in Table 2.2A, and
- (v) changes in level along an exit passageway requiring less than two risers shall be by a ramp complying with the provisions under Cl.2.3.8, and
- (vi) if the exit staircase which connects to the internal exit passageway is pressurised, the internal exit passageway shall not be naturally ventilated but shall be mechanically ventilated, and it shall be pressurised to comply with the requirements in Chapter 7.

(c) External exit passageway:

- (i) an external exit passageway can be used as a required exit in lieu of an internal exit passageway. The external wall between the exit passageway and the rest of the floor space can have ventilation openings of non-combustible construction, fixed at or above a level 1.8m, measured from the finished floor level of the passageway to the sill level of the openings and such ventilation openings shall be located not less than 3m from any opening of an exit staircase, and
- (ii) an external exit passageway may not be subjected to the limitations of a maximum of two exit doors opening into the exit passageway, and
- (iii) an external exit passageway may be roofed over provided the depth of the roofed over portion shall not exceed 3m to avoid smoke logging, and
- (iv) an external exit passageway may be enclosed on the open side by only a parapet wall of not less than 1.0 m or more than 1.1m in height and the vertical height of the unobstructed ventilation opening measured from the parapet wall up to the top edge of the opening or eaves of overhang shall not be less than 1.2m, and
- (v) exit doors opening into an external exit passageway shall have fire resistance for at least half an hour and fitted with automatic self-closing device.

EXPLANATIONS & ILLUSTRATIONS

2.3.2(b)

The above requirements are illustrated and explained in Cl.1.2.30 and Cl.2.2.13(

External exit passageway is not common in building under Purpose Group II owing to the restrictive requirements of high level ventilation of 1.8m above the finished floor level of passageway and the provision of fire doors opening into the passageway.

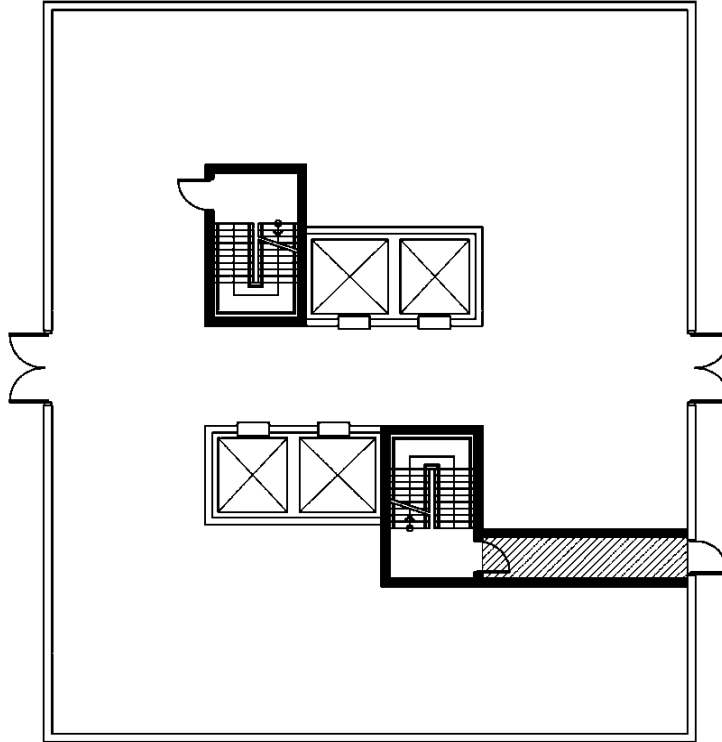

Diagram 2.3.2(b)-1

Exit passageway used to connect exit stair with exterior of building.

EXPLANATIONS & ILLUSTRATIONS

2.3.2(b)

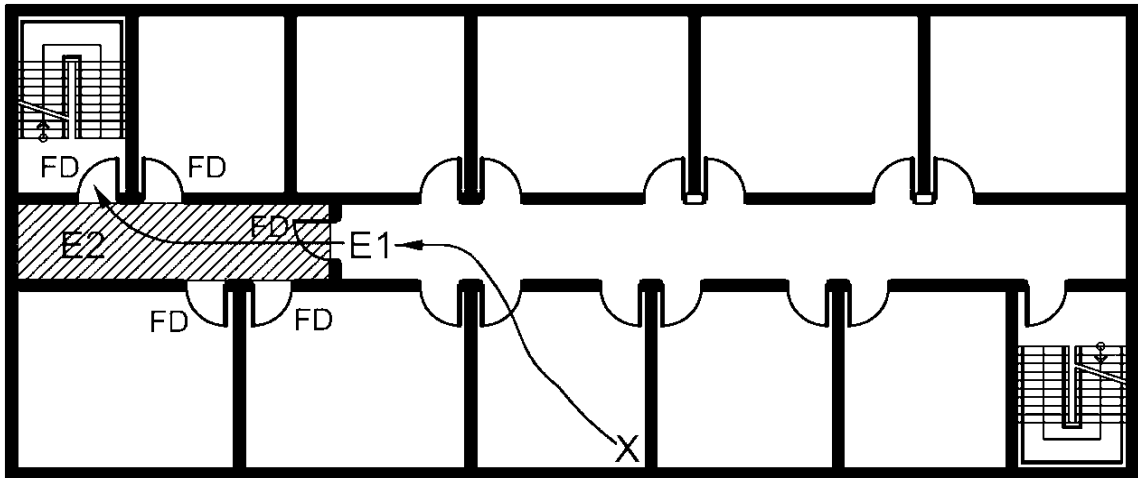

Diagram 2.3.2(b)-2

Exit passageway used to keep travel distance from becoming excessive.

The word exit used in the term exit passageway helps to distinguish the difference between an exit passageway and an ordinary passageway or corridor. An exit passageway is an exit; it provides a path of travel offering the same level of protection and safety that is required on an enclosed exit stair. An exit passageway is a versatile feature, because it can be used to extend an exit, or, as in done in many cases, it can be used to bring an exit closer to where the occupants are located.



EXPLANATIONS & ILLUSTRATIONS

2.3.2(b)

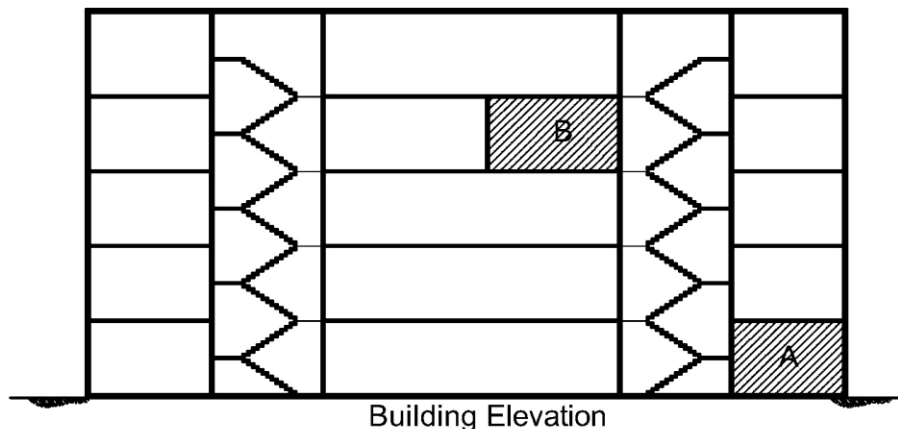

Building Elevation

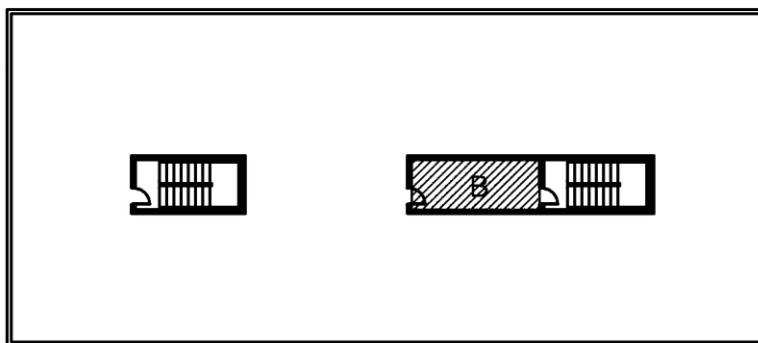

4th Floor Plan

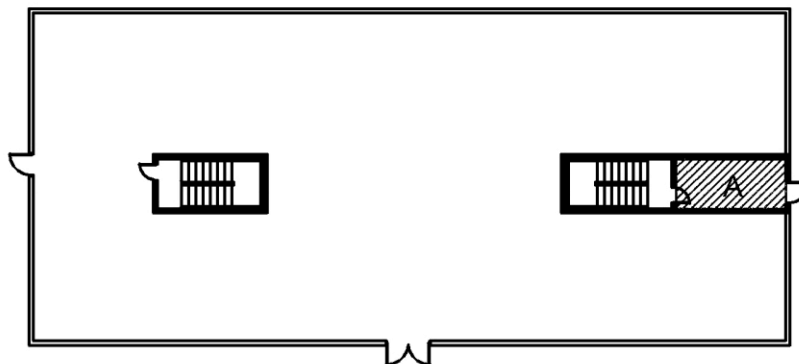

1st Floor Plan

Diagram 2.3.2(b)-3

Exit passageway with fire resistance-rated enclosures and fire protection-rated doors.

Exit passageway A on the first floor - the level of exit discharge – opens at one end to a five-storey exit stair enclosure and at the other end to a door to the outside. This exit passageway also serves as a horizontal continuation of, and discharges for, the stair enclosure. In serving as a discharge for the exit stair, the exit passageway must provide the same degree of protection required of the stair enclosure.

The exit passageway B, on the fourth floor, is used to provide the safety of an exit occupants travelling to the exit stair enclosure. This exit passageway might have been built to meet the travel distance limitation.

(d) Ventilation:

- (i) all internal exit passageways shall be naturally ventilated by fixed ventilation openings in an external wall, such ventilation openings being not less than 15 per cent of the floor area of the exit passageway, and
- (ii) internal exit passageways that cannot be naturally ventilated shall be mechanically ventilated to comply with the requirements in Chapter 7.

EXPLANATIONS & ILLUSTRATIONS

2.3.2

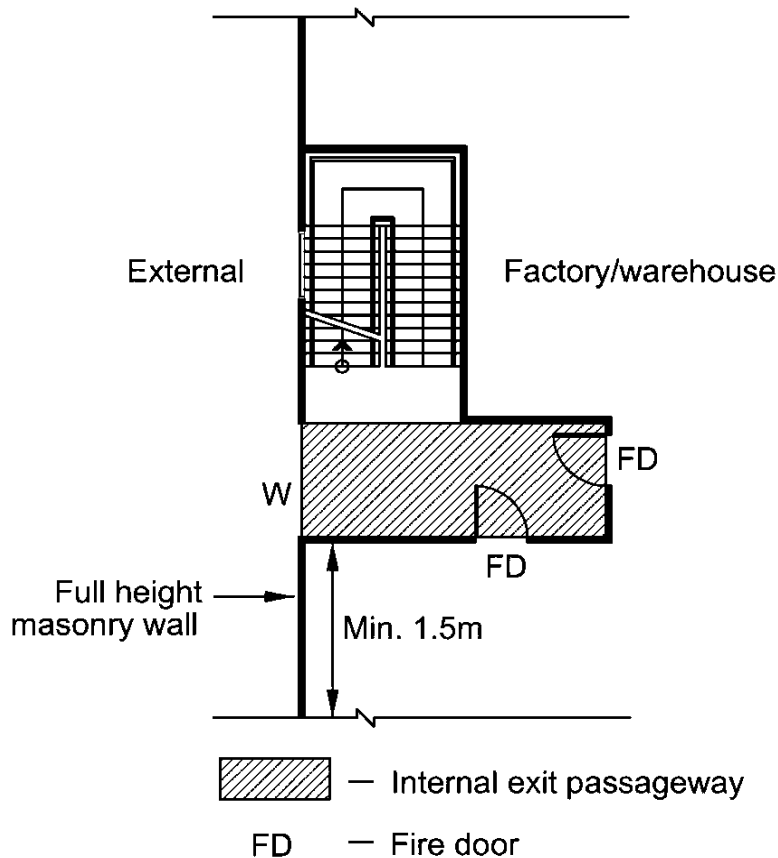

Diagram 2.3.2(d)

Natural ventilation shall be provided to all internal exit passageways. Window openings (W) shall not be less than 15% of the floor area of internal exit passageway shown above. Where internal exit passageway cannot be naturally ventilated, mechanical ventilation shall be provided to comply with Chapter 7. The number of exit doors opening into the internal exit passageway shall not exceed two.

Note: It is uncommon to design means of escape using internal exit passageway for buildings under Purpose Group II.

CHAPTER 2

2.3 MEANS OF ESCAPE REQUIREMENTS-GENERAL

2.3.3 Internal exit staircase

Exit Staircase:

(a) Internal exit Staircase

- (i) an internal exit staircase which serves as the required exit of the building shall be enclosed with construction complying with the provisions of Cl.3.8; and
- (ii) where an internal exit staircase is directly approached from an external exit passageway or external corridor, it shall not be necessary to provide such enclosure between the staircase and the external exit passageway or external corridor; and
- (iii) Unprotected Openings

there shall be no unprotected openings of occupancy area within 1.5m horizontally or within 3m vertically below any openings including final discharge openings located in the external wall of the internal exit staircase.

EXPLANATIONS & ILLUSTRATIONS

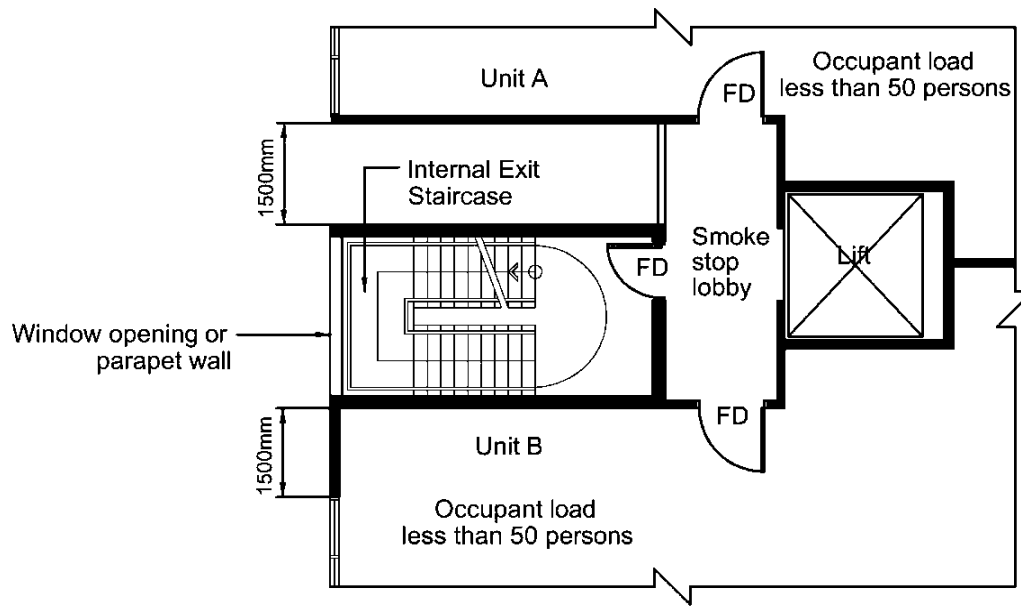

FD - Fire door

Plan

Diagram 2.3.3(a)(i)

*This is a 5-storey building. Entry to exit staircase shall be via smoke-stop lobby.
No unprotected openings of occupancy area within 1.5m horizontally from window opening of internal staircase. See cl. 3.8 for requirements on the provision of protected shaft.*

EXPLANATIONS & ILLUSTRATIONS

2.3.3(a)(ii)

Cross-ventilated exit staircase to industrial slab block with external corridor approach.

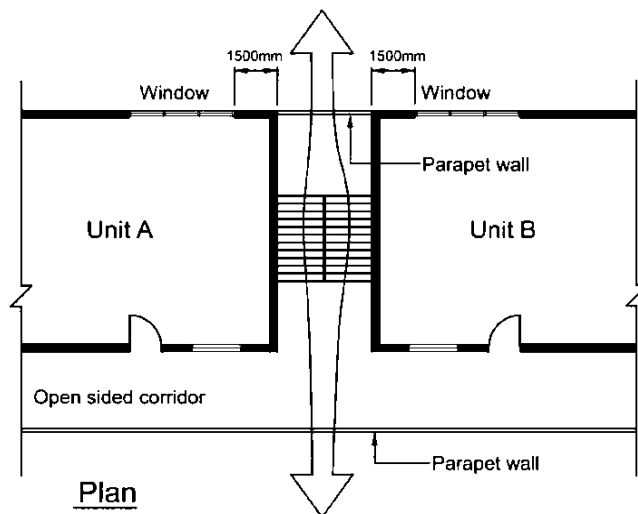

Diagram 2.3.3(a)(ii)-1

Exit staircase is cross-ventilated & maintained under smoke free condition at all times. Unprotected openings of the apartment or maisonette units are not facing (as shown in above diagram) or ventilating into the exit staircase enclosure.

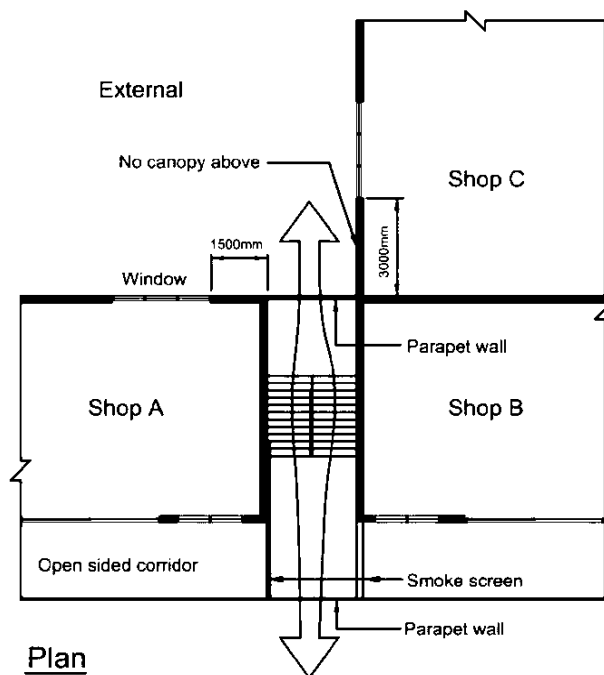

Diagram 2.3.3(a)(ii)-2

Cross ventilation provided to staircase will help to disperse smoke more readily. No unprotected openings from the shop units should face or ventilate into the exit staircase enclosure. The rear portion of shop unit C shall have 3m blank wall next to the staircase, otherwise smoke could be channelled into the staircase where there is a fire in the shop.



EXPLANATIONS & ILLUSTRATIONS

2.3.3(a) (iii)

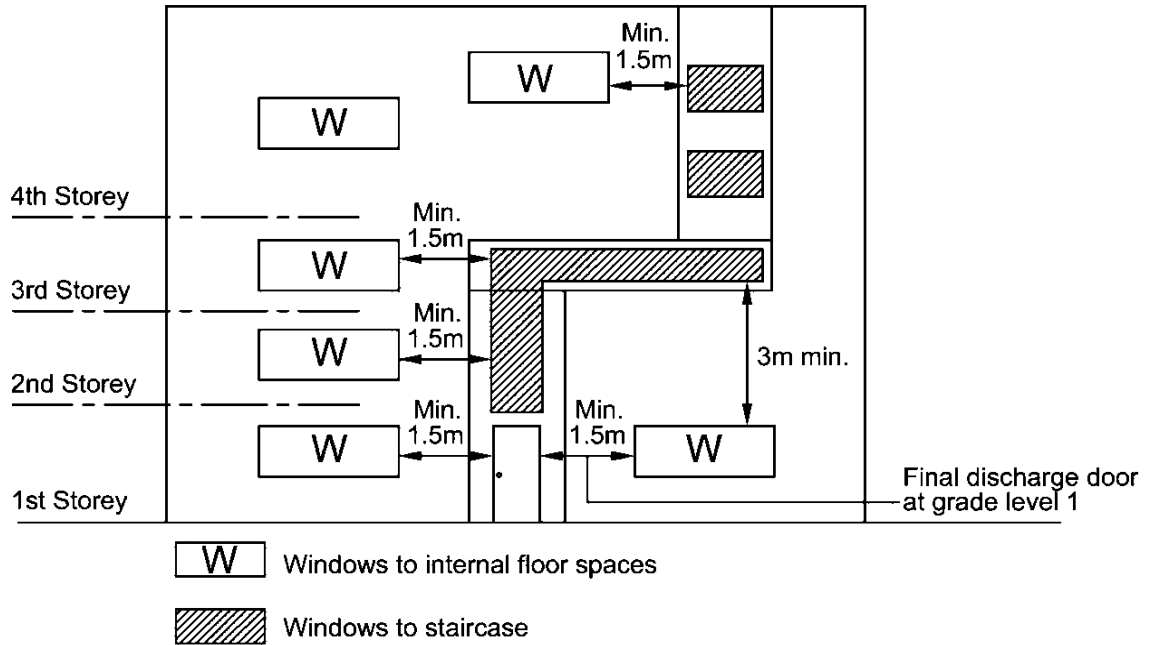

Elevation

Diagram 2.3.3(a)(iii)-1

Unprotected openings of external wall to staircase.

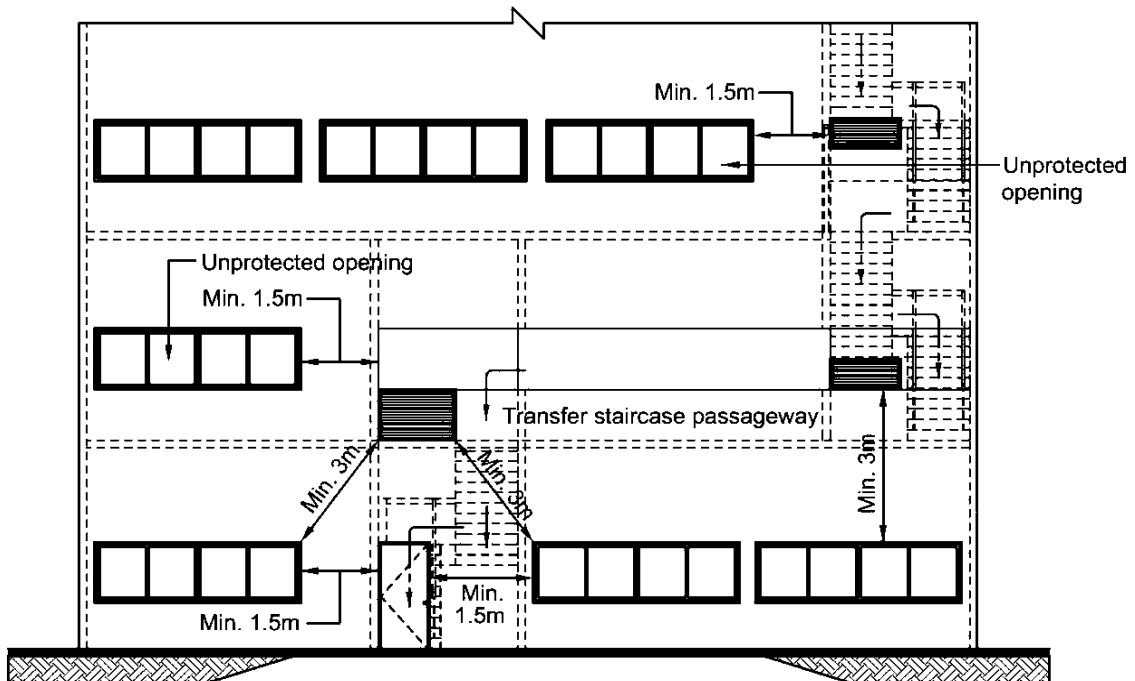

Diagram 2.3.3(a) (iii)-2

Unprotected openings of external wall to staircase.



(a) (iv) Exception:

(1) Single storey basement car park

Exit staircases serving single storey basement car park are not required to be protected with fire rated enclosures, provided the travel distances in the car park are measured to the exit doors at ground level and comply with Table 2.2A of the Fire Code.

EXPLANATIONS & ILLUSTRATIONS

2.3.3

The reasons for the relaxation are:

- (1) The car parking areas are usually unenclosed, provided with either automatic fire alarm system. Thus fire risk can be considered acceptable.*
- (2) Car parking areas are usually not occupied, except during the times when people are parking or retrieving their cars.*
- (3) Adequate ventilation, either by natural or mechanical means.*
- (4) Only single basement floor is involved*



(a) (iv) Exception:

(2) Standalone car park

Doors to exit staircases of standalone car park buildings that are without any commercial activities or non-ancillary usage can be omitted, provided that the following conditions are fully complied with:

- * The car park building shall not exceed 5 storeys above ground. It shall not consist of any basement storey, and shall not be connected to other building, except by open-sided covered link-way;
- * At least two exit staircases shall be provided to serve every upper storey. The two staircases shall be located as remotely from one another as practicable. The exit openings to the staircases at each storey shall have a clear width of not wider than 1000mm or less than 850mm and a clear height of not more than 2200mm. The staircases shall be ventilated by fixed openings in the external walls, such openings being of area not less than 10 per cent of the floor area per floor of the staircase. Exit staircase and occupancy area shall not share the same air-well or void for lighting and ventilation;
- * Every storey shall be provided with cross ventilation. The building shall be open sided having not less than 50% of the sides (front, rear and sides elevations) permanently open, and such openings being evenly distributed around the perimeter walls, excluding perimeter walls to air-well, so as to provide effective cross ventilation to all parts of the car parking decks;
- * No part of the floor space shall be more than 12m from the openings on the perimeter walls of the building or air-well. Air-well where provided for this purpose shall have a superficial plan area of not less than 10m², and have a minimum dimension on plan of 2000mm, open vertically to the sky for its full height;
- * Travel distance within each car parking deck shall comply with Table 2.2A. For upper storeys, the travel distance requirement shall be measured to a position where the exit door to the staircase would be installed if otherwise required; and
- * The separation distance between the nearest edge of exit opening to exit staircase and the nearest edge of any vehicle parking lot shall not be less than 3m.

EXPLANATIONS & ILLUSTRATIONS

2.3.3

Fire modelling using a typical model of a 3-storey car park building to evaluate whether the fire rated doors to exit staircases within the multi storey car park (MSCP) could be permitted. The results gathered from the study indicated that occupants are able to escape safely from the staircases without being subject to untenable conditions in terms of temperature and visibility.

To qualify for the omission of the fire rated doors in standalone car park building, the exit staircase must be positioned as remotely from one another as possible. The rationale of stipulating exit opening size is to avoid total removal of the staircase enclosures. In addition, the car park buildings must be without commercial activity or non-ancillary usage. The 3m buffer separation distance between the exit door and the nearest car park lot is intended to provide unobstructed movements to occupants getting in and out of the staircase. Please note that the omission of fire door to exit staircases is a relaxation and will eliminate maintenance aspects.

(b) External Exit Staircase

- (i) external exit staircase may be used as required exit in lieu of internal exit staircase provided it complies with the requirements of exit staircase, except for enclosure of an internal staircase, and
- (ii) there shall be no unprotected openings within 3m horizontally or within 3m vertically below, or adjacent or facing (unless there is adequate separation complying with Cl.3.5) any part of the external exit staircase; and Exception:

In building designed with external corridor access, the access to the external exit staircase shall be permitted by means of the open sided external corridor adjoining the occupancy areas, subject to the following:

- (1) the external corridor shall be served by at least 2 exit staircases; and
- (2) That unobstructed ventilation openings shall be provided along the long side of the external corridor above the parapet or balustrade.
- (iii) The external exit staircase shall be located so as to lead directly to a street or open space with direct access to street.
- (iv) Doors to the external exit staircases can be omitted, if the conditions given in sub-clause 2.3.3(a) (iv) are fully complied with.

EXPLANATIONS & ILLUSTRATIONS

2.3.3

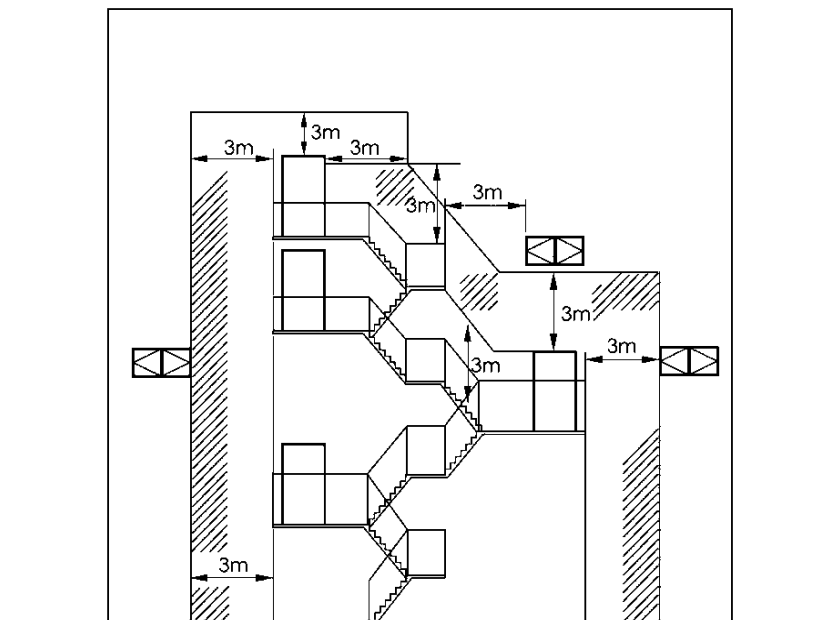

(Walls within this area must be at least 1 hour rated)

Diagram 2.3.3(b)(ii)-1

EXPLANATIONS & ILLUSTRATIONS

2.3.3(b)(ii)

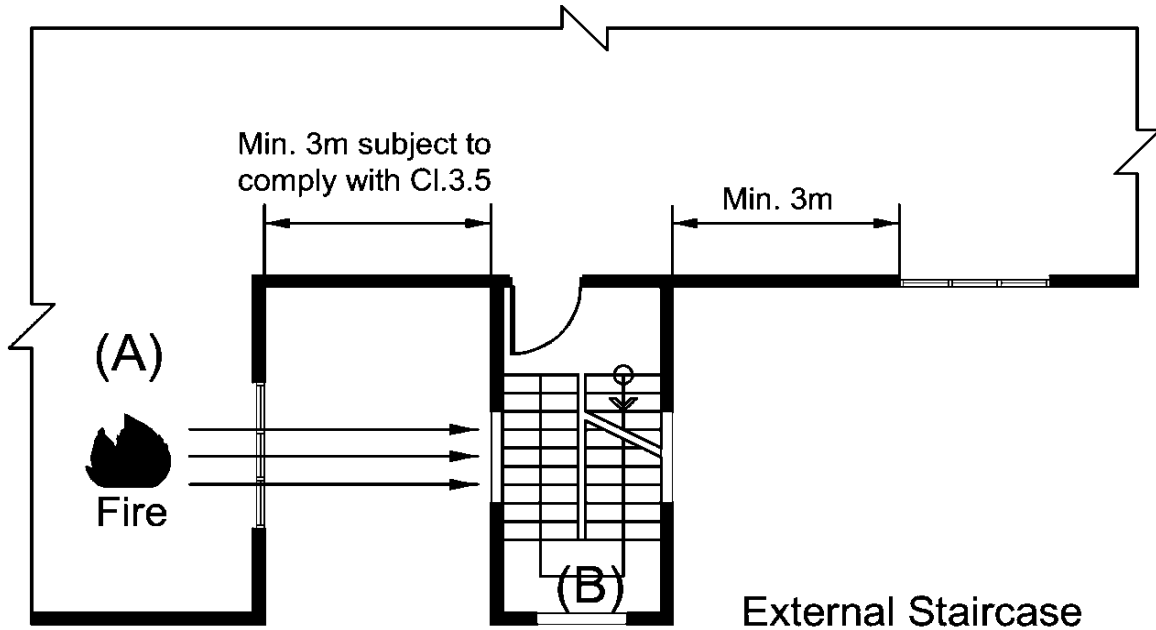

Diagram 2.3.3(b)(ii)-2

Requirements on setback requirements under cl.3.5 shall be used to determine the separation distance between building's openings at A and staircase's openings at B, subject to minimum 3m.

Heat radiation from a fire through external window in part of the building at (A) would affect occupants escaping down the external staircase at (B). To avoid this situation, the separation distance between that part of the building and the staircase shall comply with the separation requirements under Cl. 3.5.

Cl.3.5 would prescribe the separation distance between that part of the building (A) and the external staircase (B) in accordance with the amount of unprotected openings provided in the external wall to part of the building (A).

Alternatively, to omit the unprotected openings in the external wall of staircase (B) facing part of the building (A).



EXPLANATIONS & ILLUSTRATIONS

2.3.3(b)(ii)

Building with external corridor access, the access to external exit staircase shall be open sided adjoining the occupancy areas

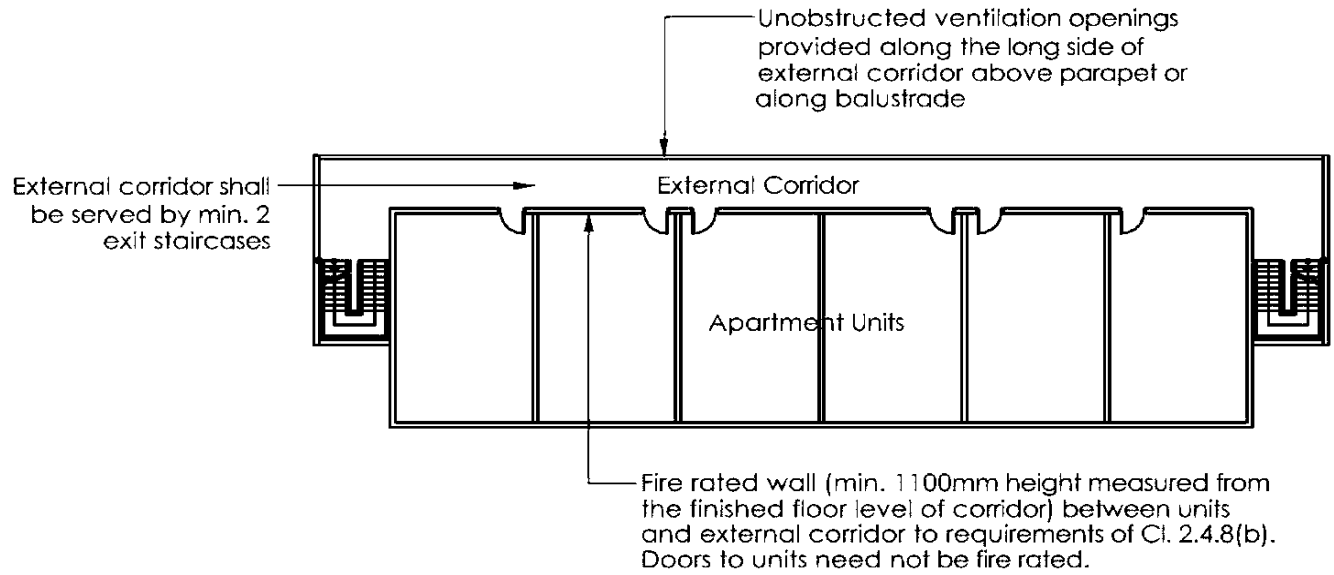

Diagram 2.3.3(b)(ii)-3

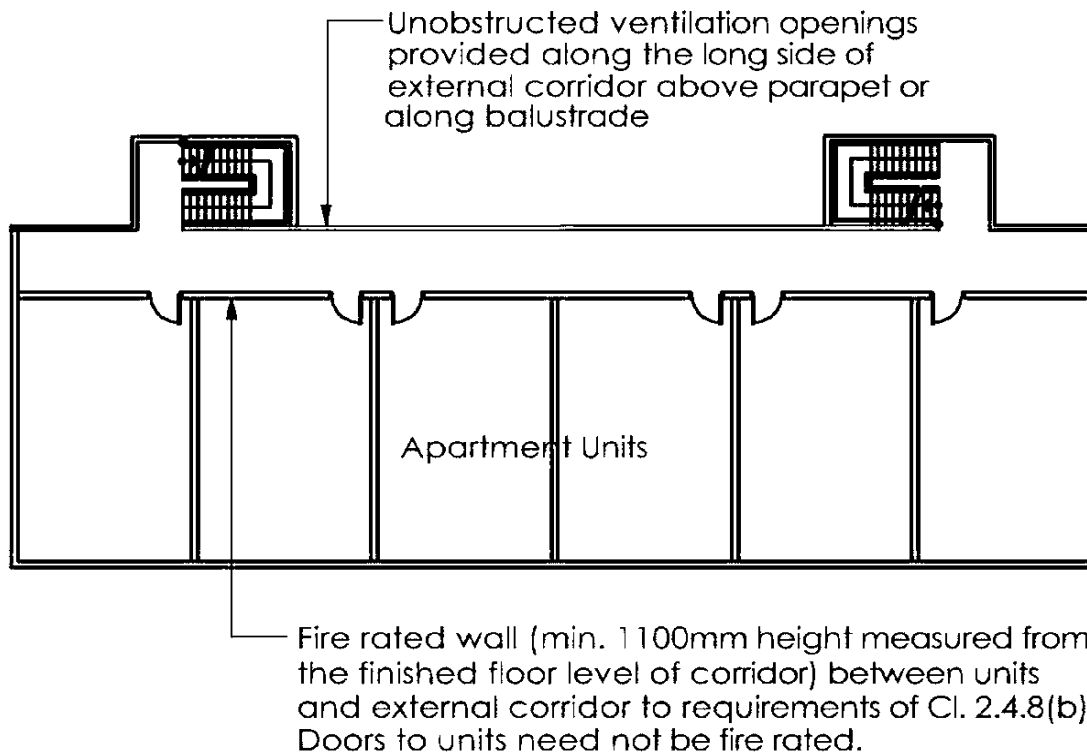

Diagram 2.3.3(b)(ii)-4

(c) Discharge

- (i) All exit staircases shall discharge at ground level directly into a safe exterior open space opened to sky. Open-sided external corridor which does not have any commercial activity and not more than 5m measured to the building eave line shall be considered as safe exterior space. In a sprinkler protected building, maximum 50% of the total number of exit staircase is allowed to be discharged directly to the ground level covered circulation space subject to the following:
- (1) The discharge point of the exit staircase into the ground level circulation space shall be within sight of and with direct access to a safe exterior open space; and
 - (2) The maximum distance between the discharge point of an exit staircase and the exterior open space opened to the sky shall not exceed 10m; and
 - (3) Where there are commercial activities e.g. shops or kiosks/carts located along one side or both sides of the designated escape passageway leading to the safe exterior open space, a minimum separation distance of 10m shall be maintained between the commercial activities and the designated escape passageway. The circulation space shall also be installed with engineered smoke control system. Alternatively the commercial activities shall be fire compartmented with walls and doors of minimum one-hour fire resistance rating.
 - (4) The clear width of exit doors leading to the safe exterior open space shall be adequate to receive the occupant load in the 1st storey circulation space and the total number of people discharging from the internal exit staircases.

EXPLANATIONS & ILLUSTRATIONS

2.3.3

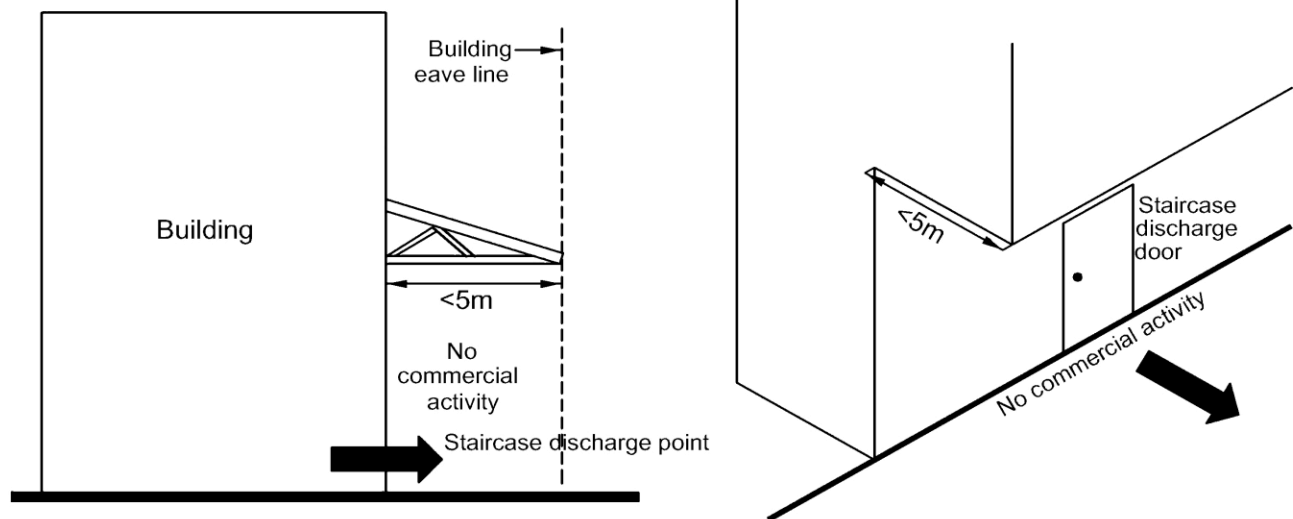

Diagram 2.3.3(c)(i)-1

Note: This relaxation follows the exemption for sprinkler provision for external open-sided link ways not exceeding 5m in width. There shall be strictly no commercial activities or storage within these areas.



EXPLANATIONS & ILLUSTRATIONS

2.3.3(c)(i)

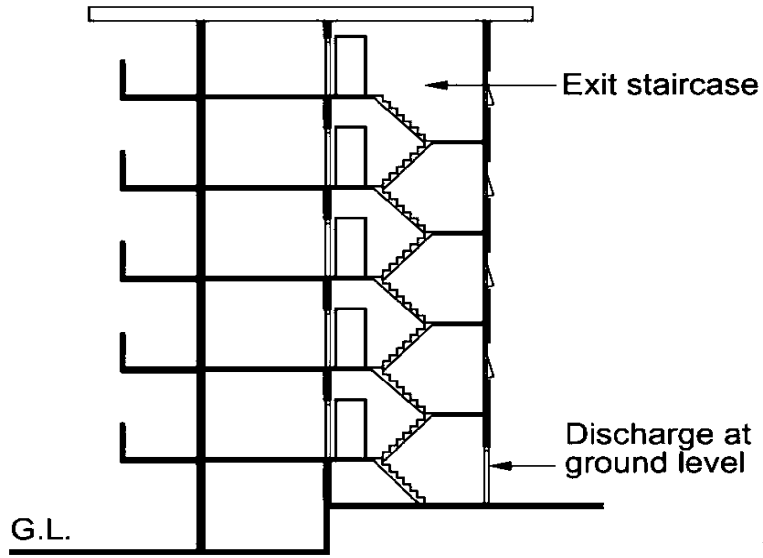

Diagram 2.3.3(c)(i)-2

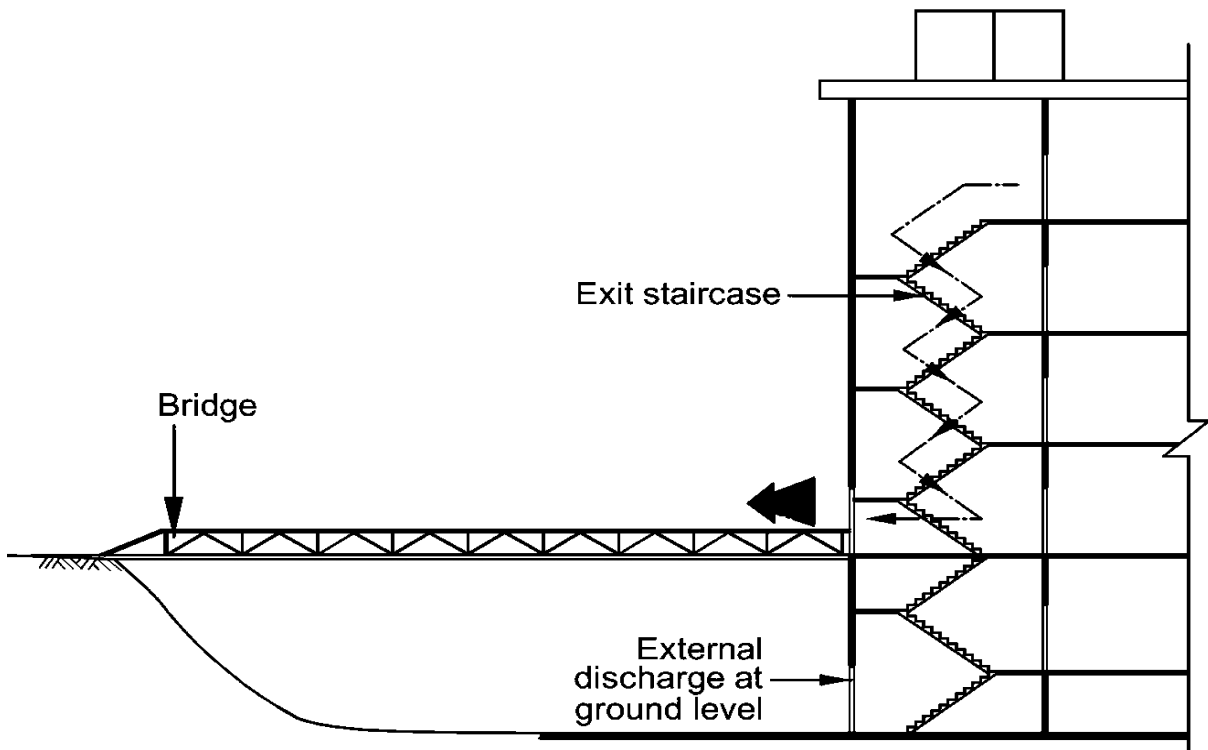

Diagram 2.3.3(c)(i)-3

Exit staircase is provided with discharge into unenclosed bridge leading to safe exterior space at ground level.

EXPLANATIONS & ILLUSTRATIONS

2.3.3(c)(i)

Provision of adequate separation between commercial spaces and exit path

Currently, the code allows minimum 50% of the staircase exits in a sprinkler protected building to be discharged through the ground level circulation space, which must be within 10m from exterior safe area. As there is possibility that part of the circulation space is used for commercial activities such as shops and kiosks

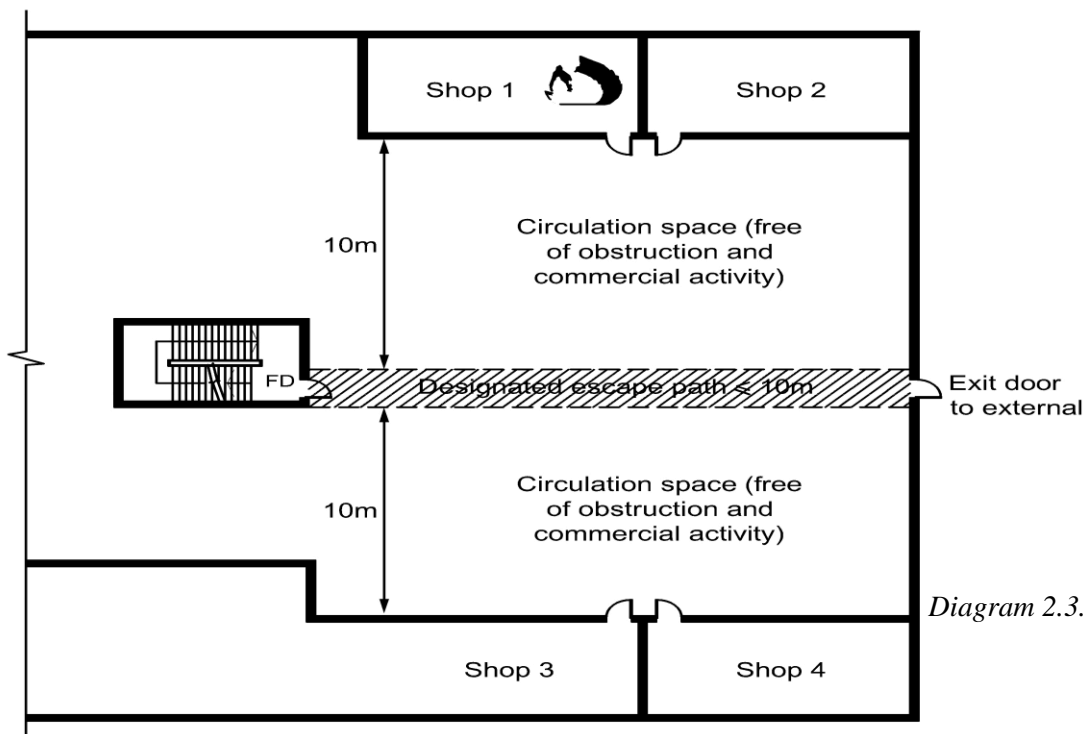
Standard distance between shop and designated escape route

- (ii) In the case of a Purpose Group II residential building not fitted with an automatic sprinkler system, at least 50% of the total number of exit staircases shall discharge to the safe exterior space opened to the sky and the remaining exit staircase is allowed to be discharged onto the ground level covered circulation space subject to the following:
1. The ground level covered circulation space shall be free on any commercial activity; and
 2. The discharge point into the ground level circulation space shall be within sight of and provided with at least two alternative routes to the safe exterior space opened to sky; and
 3. The maximum distance between the discharge point of an exit staircase and the safe exterior space opened to the sky shall not exceed in 10m; and
 4. There shall not be more than 4 residential units opening into the designated escape passageway at grade level into which the exit staircase discharges; and
 5. The discharge point of an exit staircase shall be effectively cross-ventilated such that:
 - * each end has at least 50% permanent openings; and
 - * Not part of the circulation space shall be more than 10m from the openings on the perimeter walls of the building or air-well.

EXPLANATIONS & ILLUSTRATIONS

2.3.3(c)

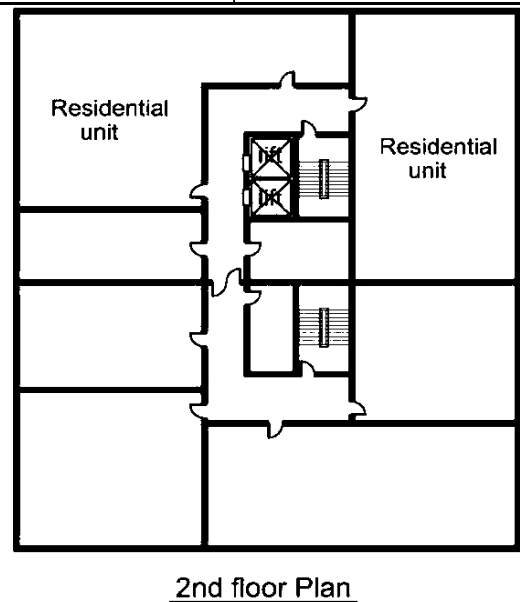
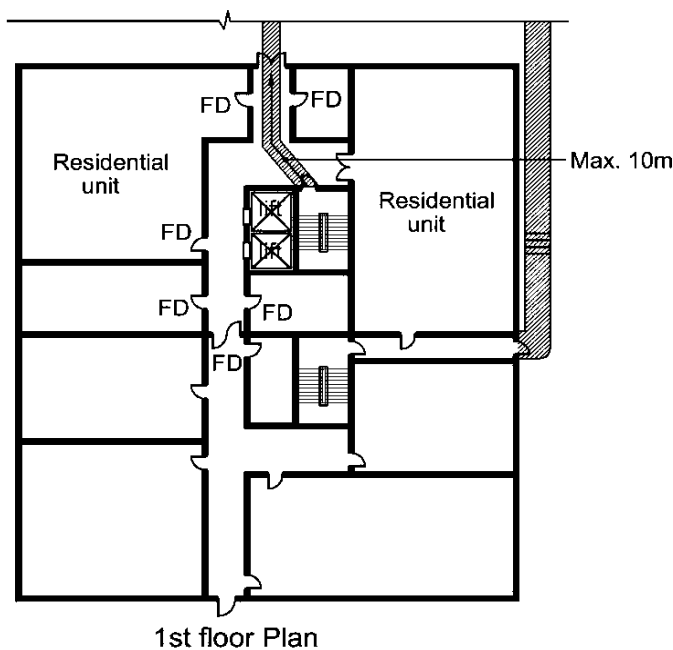

Diagram 2.3.3(c) (ii)

Spaces consisting exit discharge.

Building occupants with path of travel from the termination of an exit to a public way. This path of travel might be inside the building, or outside. Where an exit opens onto an alley, court, or yard, a safe path of travel is to be provided to a public way or some equivalent safe area. This portion of the means of egress is the exit discharge.

Forms of exit discharge are shown in diagram 2.3.3(c) (ii) as shaded areas.



(iii) There shall be no unprotected openings of occupancy area within 3m from discharge point of the exit staircase (both internal and external). This distance can be reduced to 1.5m if the unprotected openings are along the same plane of the staircase exit.

EXPLANATIONS & ILLUSTRATIONS

2.3.3(c)

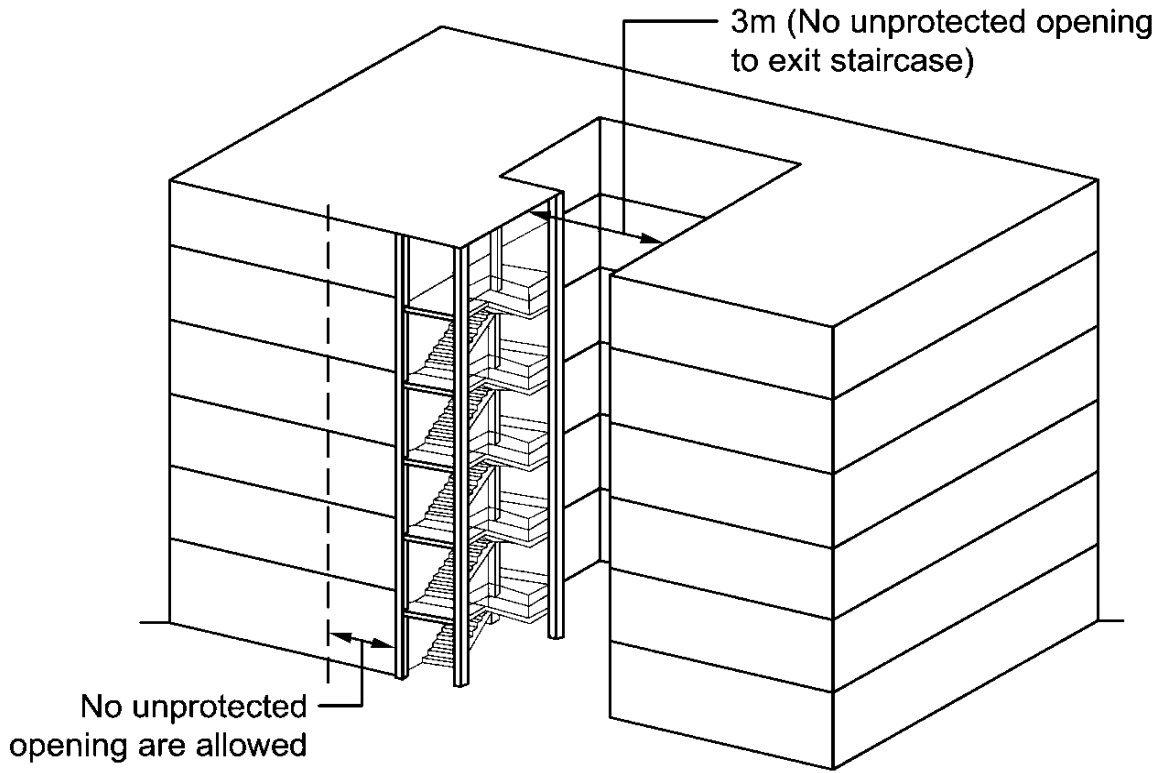

Diagram 2.3.3(c)(iii)-1

If an unprotected opening was next to the exit staircase, a separate distance of 3m was required. However, this distance can be reduced to 1.5m horizontal distance if the unprotected openings are along the same plane of the staircase exit.

EXPLANATIONS & ILLUSTRATIONS

2.3.3(c) (iii)

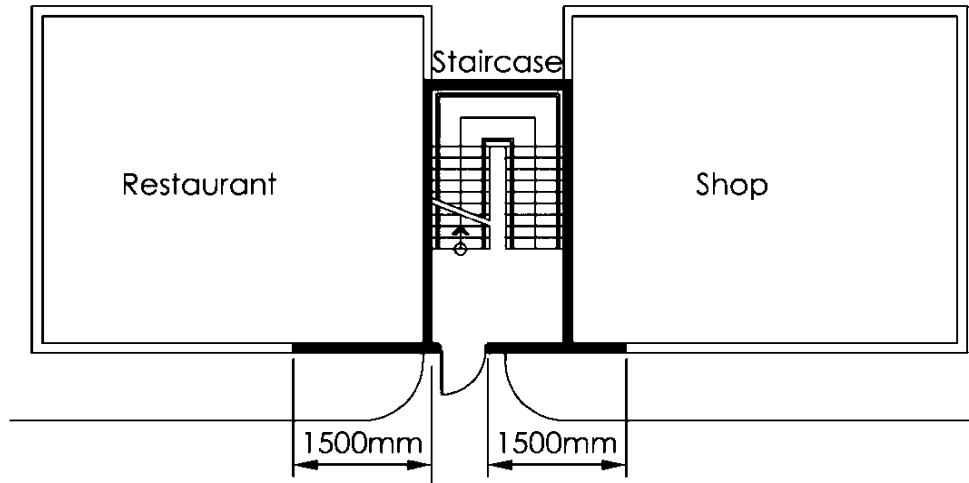

Diagram 2.3.3(c)(iii)-2

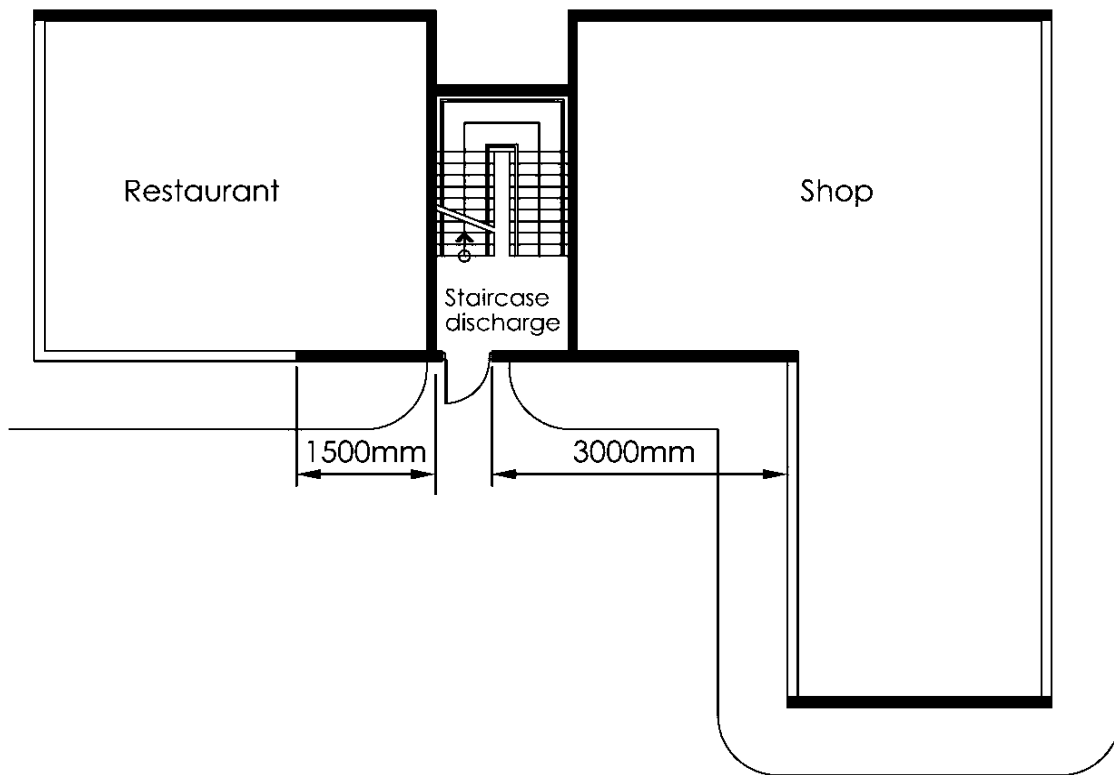

Diagram 2.3.3(c)-(iii)-3



(d) The minimum width and capacity of exit staircases shall be as specified in Table 2.2A, and such staircases shall comply with the following:

(i) Winders

Winders shall not be permitted in any building other than for access staircases in a residential unit and in such cases, there shall be not more than 1 winder per 90 degree turn.

(ii) Treads for circular staircase

Where circular staircase is used as exit staircases or access staircase in Purpose Group I & II, the width of treads measured at the narrower end shall be not less than 100mm in residential buildings and 125mm in other buildings and at a distance of half metre from the narrower end shall be not less than 225mm in residential buildings and 250mm in other buildings. Such staircase shall not be more than 10m in height.

EXPLANATIONS & ILLUSTRATIONS

2.3.3

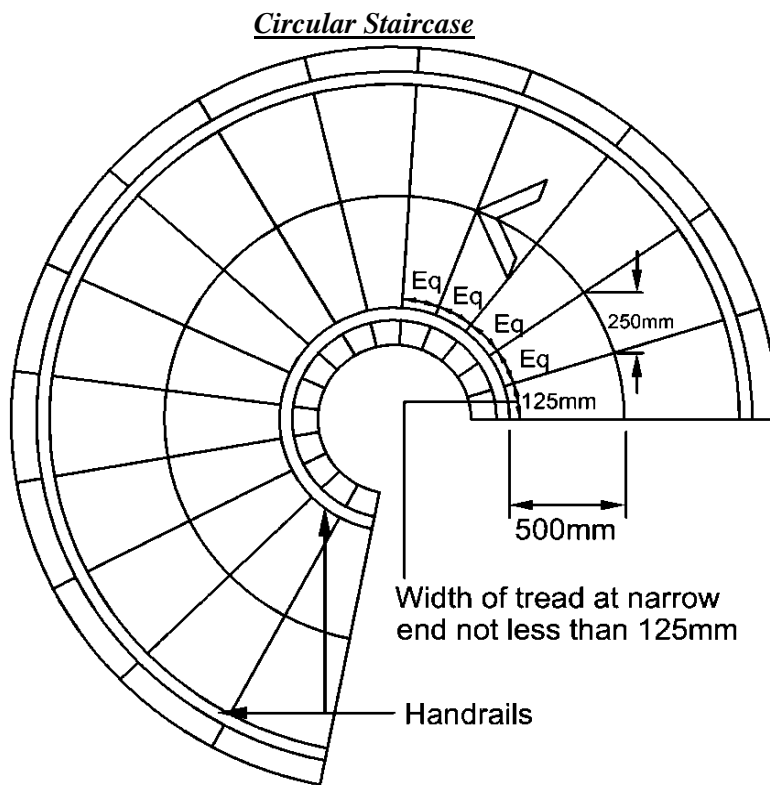

Diagram 2.3.3(d) (ii)-1

Circular staircases are not recommended for use as exit staircases due to their varying tread size, which can cause escaping occupants to lose footing and falling more frequently than straight run staircases. However, it may be permitted with limitations as provided for under Cl.2.3.7, or otherwise consented by the MFRS.



EXPLANATIONS & ILLUSTRATIONS

2.3.3(d) (ii)

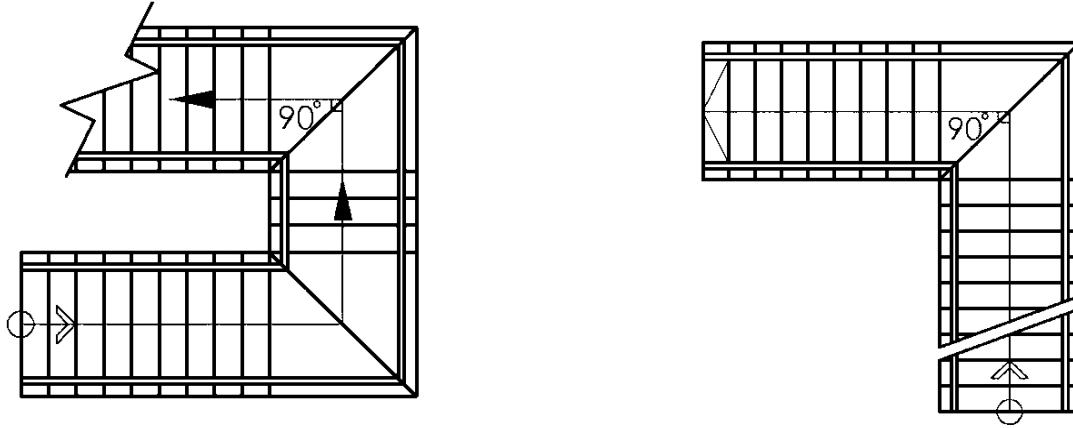

Diagram 2.3.3(d) (ii)-2

Winders are only permitted in access staircase within the residential unit. They shall not be provided in exit staircase. Winder is a tapered tread used to change the direction of a stairway. As it introduces a sudden change in the stair geometry, winder could cause unwary occupants to trip and thus winder is not permitted in non-residential building.



(e) Handrails

- (i) every exit staircase shall have walls, grilles or handrails on both sides, except that staircases that are 1250mm or less in width, can have a handrail one side only; and
- (ii) Where the width of the exit staircase exceeds 2000mm, handrails shall be provided in accordance with the requirements of Cl.2.2.8.

EXPLANATIONS & ILLUSTRATIONS

2.3.3

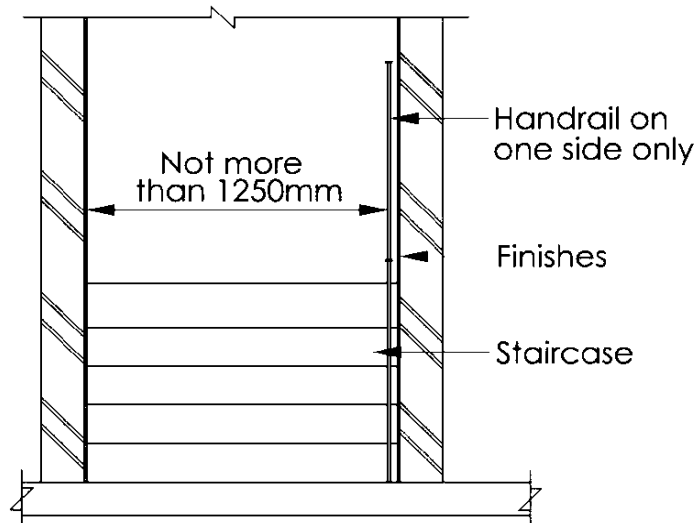

Diagram 2.3.3(e) – 1

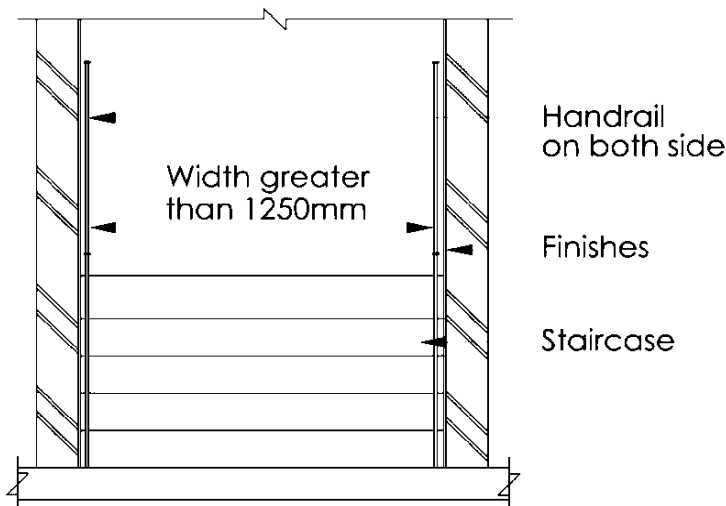

Diagram 2.3.3(e) – 2

Handrail provides support for people using the stair. It also serves as a guide when, as sometimes happened, smoke enters the stairway in a quantity sufficient to interfere with one's vision or when the stair lighting system fails. Handrail may be constructed of timber or metal with plastic finish

(f) Ventilation

All exit staircases shall be ventilated by fixed openings in the external walls, such openings being of area not less than 10 per cent of the floor area per floor of the staircase, or mechanically ventilated to comply with the requirements in Chapter 7. Ventilation openings fronting an airwell, external recessed space or external shall be in accordance with Table 1.2.1(A). Exit staircase and occupancy area shall not share the same airwell or void for lighting and ventilation. Mechanical ventilation is not allowed for Purpose Group II, except for staircase storey shelter.

EXPLANATIONS & ILLUSTRATIONS

2.3.3

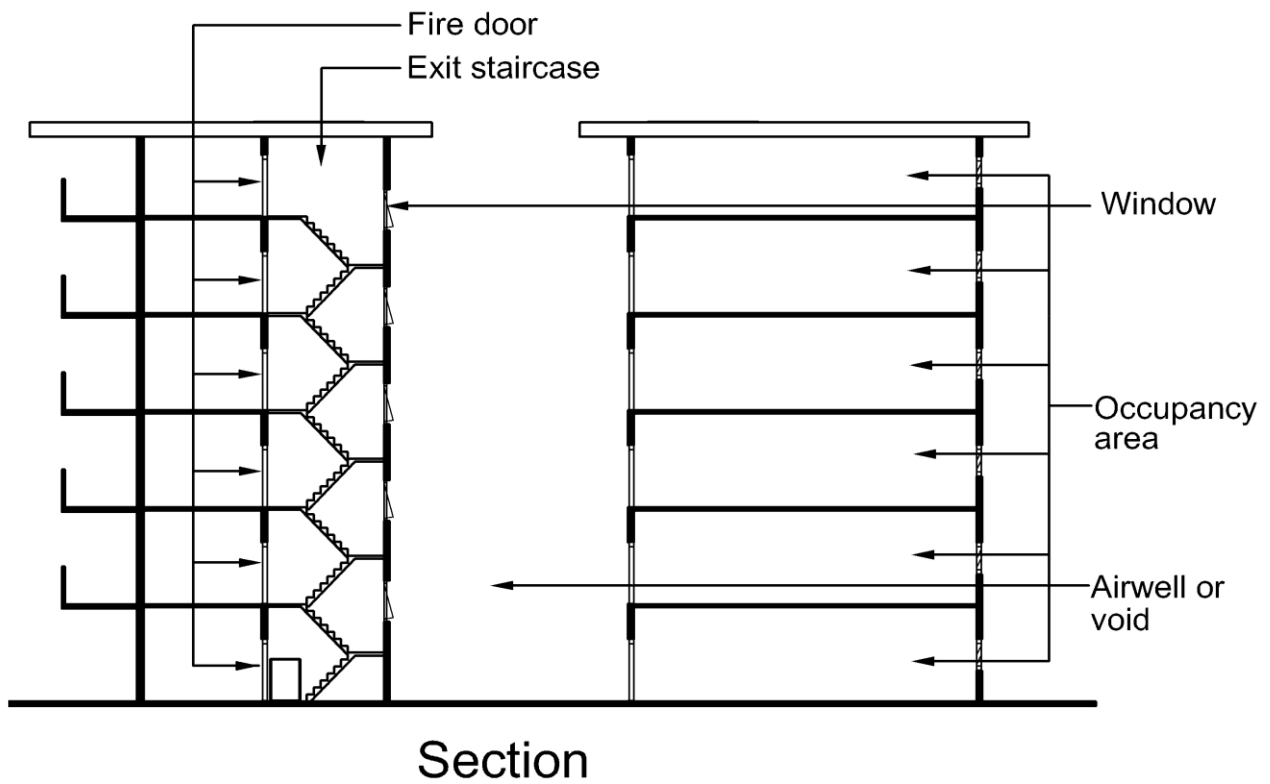

Diagram 2.3.3(f)-1

Exit staircase and occupancy area shall not share the same air well or void for lighting and ventilation to prevent smoke from being drawn into the staircase, unless otherwise permitted by the MFRS.



(g) Pressurisation

In any building of which the habitable height exceeds 24m, any internal exit staircases without provision for natural ventilation shall be pressurised to comply with the requirements in Chapter 7. In a building comprising more than four basement storeys, the exit staircase connecting to the fire fighting lobby shall be pressurized.

EXPLANATIONS & ILLUSTRATIONS

2.3.3

No Illustration.

For illustration, please refer to Cl. 2.2.13 and Cl.2.2.14

In addition to the provision of pressurization, the entry into the internal staircase shall be through a smoke-stop lobby. The smoke-stop lobby acts as a buffer to prevent smoke from getting into the staircase. It is not common to have pressurized staircase for buildings under purpose group II.

Where the internal exit staircase is pressurized, please note that there must be a means to activate the pressurization fan system.

I.e. call point located at the entrance of each exit staircase at every storey, including the non-residential floors. Activation of any manual call point shall initiate mechanical system / and or the pressurization system simultaneously.

(h) Different modes of ventilation within a single staircase shaft

For buildings exceeding 24m in habitable height, the internal exit staircase can be naturally ventilated at its upper part and mechanically ventilated at its lower part provided this lower part does not exceed 24m in habitable height and there shall not be any intermediate staircase landing door separating the 2 modes of ventilation. If the lower part exceeds 24m in habitable height, this lower part shall be pressurized instead.

EXPLANATIONS & ILLUSTRATIONS

2.3.3

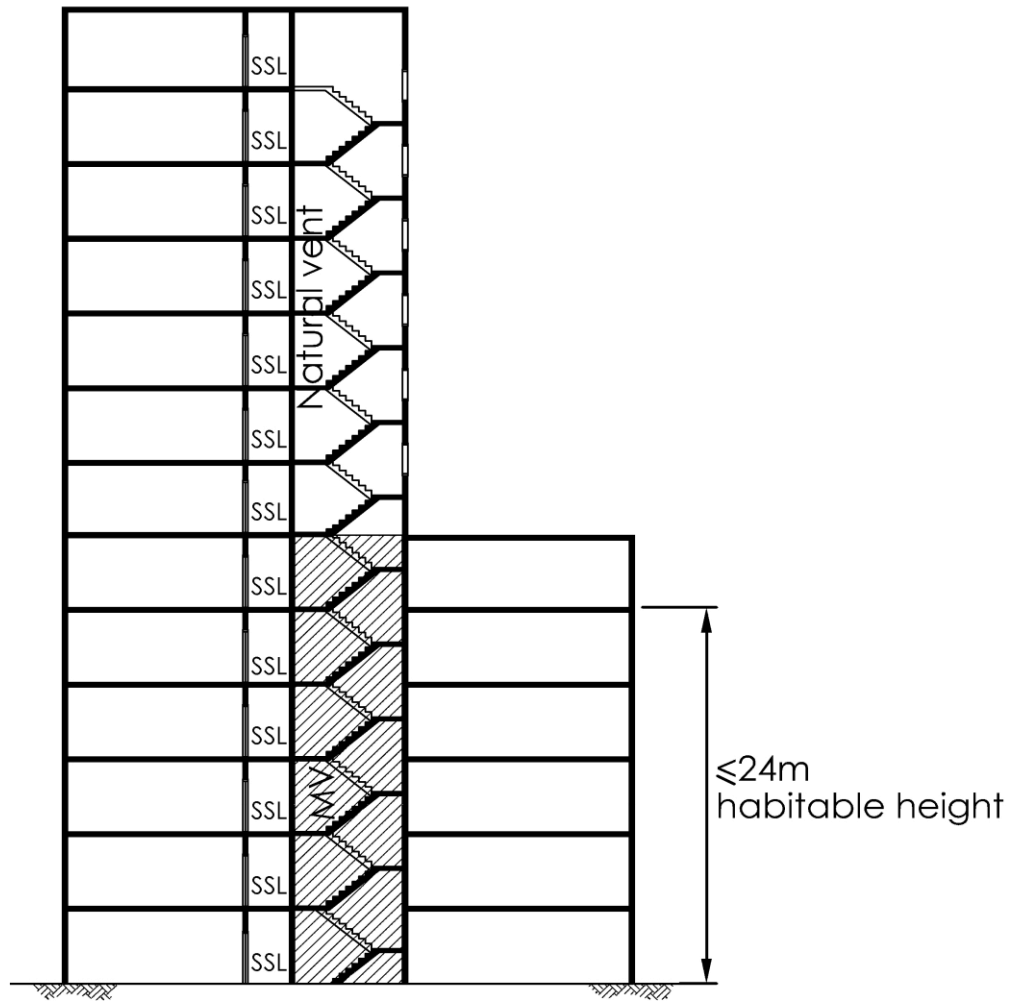

Diagram 2.3.3(h)-1

This is a relaxation towards the mode of ventilation whereby the lower part of exit staircase is mechanically ventilated instead of pressurized. This provision is only possible if the habitable height of the lower part of staircase shaft is less than 24m. No door is required within the staircase shaft to separate different mode of ventilation provision.



EXPLANATIONS & ILLUSTRATIONS

2.3.3(h)

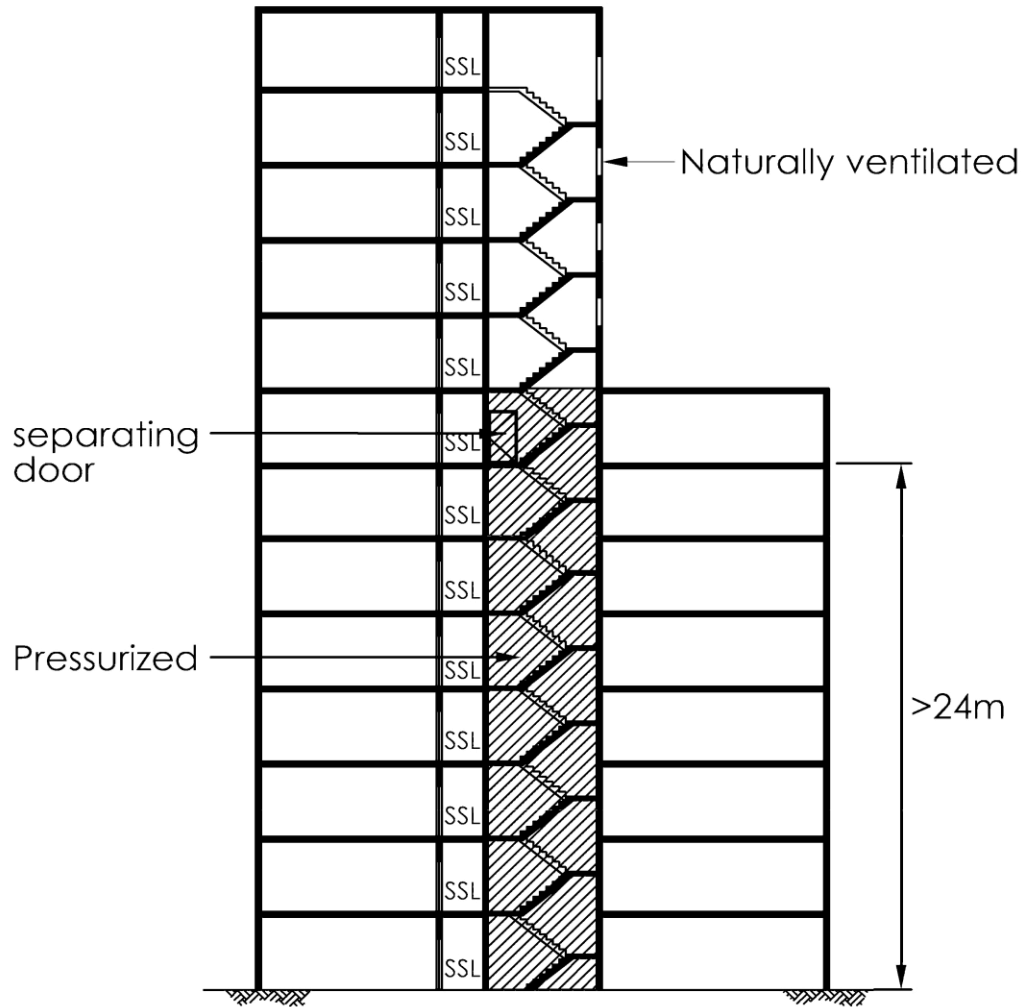

Diagram 2.3.3(h)-2

Lower part of staircase shaft where habitable height exceeding 24m, it shall be pressurized. Door at the mid-landing separating the naturally ventilated and pressurized portion of exit staircase shall be provided to enable effective pressurization.

CHAPTER 2

2.3 MEANS OF ESCAPE REQUIREMENTS-GENERAL

2.3.4 Scissor Exit Staircase

Scissor Exit Staircase

- (a) Where two separate internal exit staircases are contained within the same enclosure, each exit staircase shall be separated from the other by non-combustible construction having fire resistance for a minimum period equal to that required for the enclosure, and
- (b) Such scissor exit staircases shall comply with all applicable provisions for exit staircase, and
- (c) Door opening into scissor exit staircases shall be at least 7m measured as travel distance between the two closer edges of the staircase doors, and
- (d) Where there is only one pair of scissor exit staircases, the door opening into scissor exit staircases shall be spaced at least $\frac{1}{3}$ the diagonal dimension of the area to be served in a sprinkler protected building and $\frac{1}{2}$ the diagonal dimension in a non-sprinkler protected building in accordance with C1.1.2.60, and
- (e) The ventilation openings of each staircase shall be located on alternate storeys if such openings or windows are serving both staircases on the same wall.

EXPLANATIONS & ILLUSTRATIONS

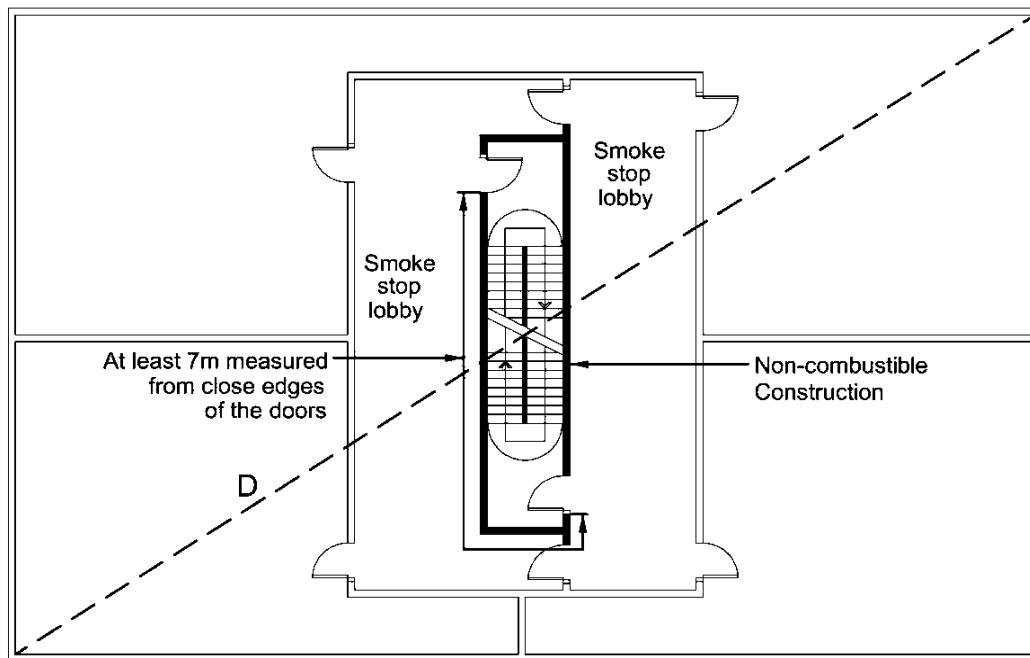

Diagonal distance of floor is D. Distance between doors of scissors staircase has to be at least $\frac{1}{3}D$ for a sprinklered building and $\frac{1}{2}D$ for a non-sprinklered building.

Diagram 2.3.4(a), (b), (c) & (d)

EXPLANATIONS & ILLUSTRATIONS

2.3.4(e)

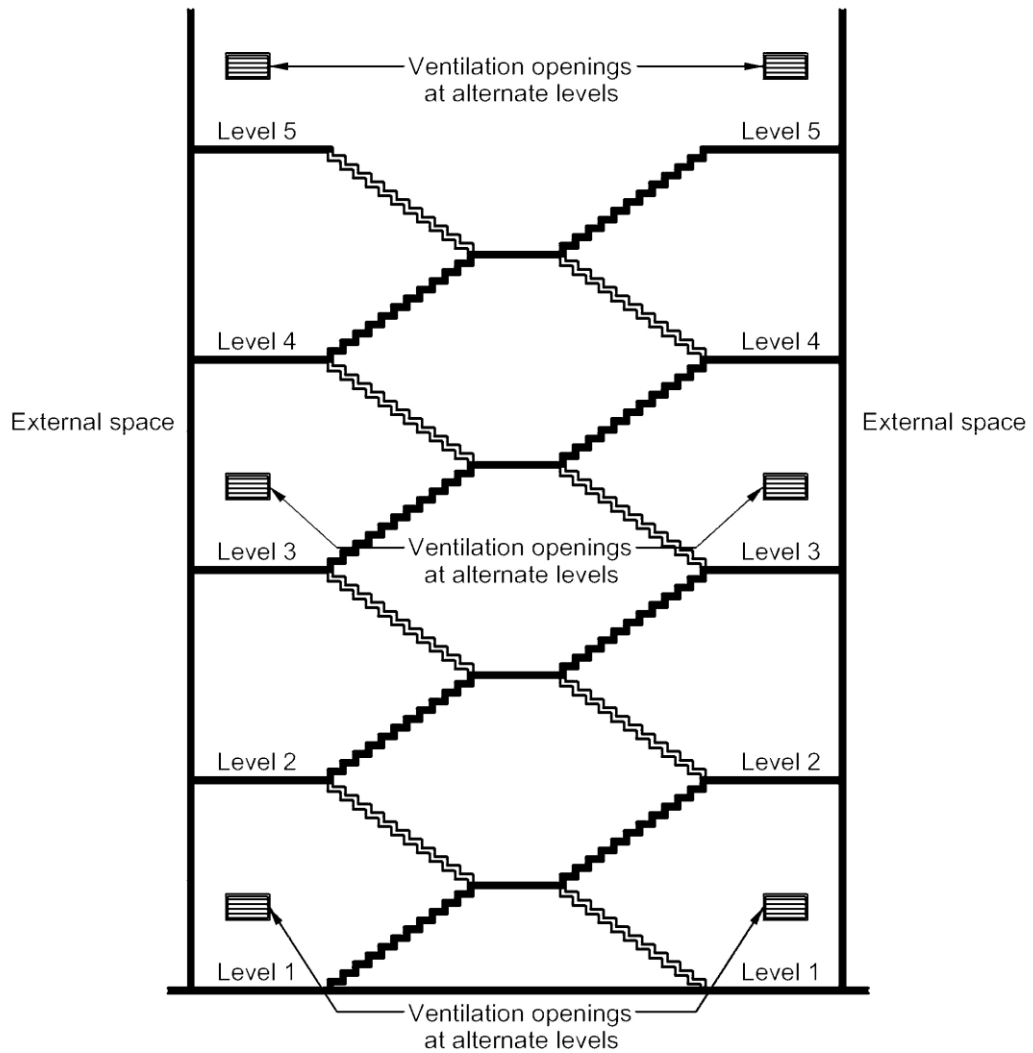

Diagram 2.3.4(e)-1

Ventilation opening sizes are to comply with Clause 2.3.3(f).

Where there is only one pair of scissor exit staircases, designer shall ensure sub-clause (d) is strictly adhered to. If the minimum 7m is less than the computed diagonal distance, the designer shall apply the latter diagonal separation distance.



EXPLANATIONS & ILLUSTRATIONS

2.3.4(e)

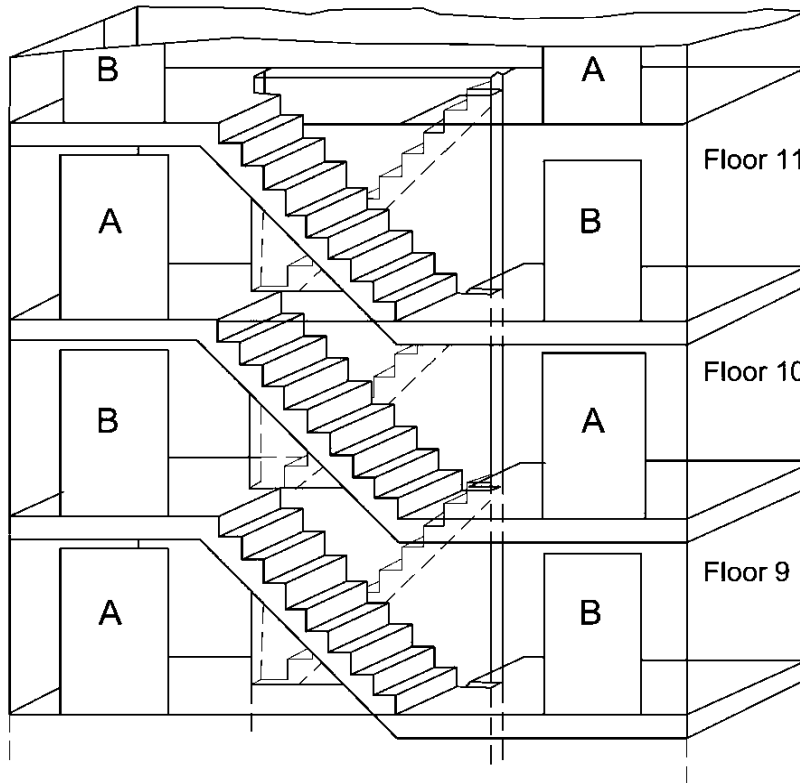

Diagram 2.3.4(e)-2

Scissors stairs.



CHAPTER 2

2.3 MEANS OF ESCAPE REQUIREMENTS-GENERAL

2.3.5 Basement exit staircase

(a) Basement exit staircase

Any exit staircase which serves a basement storey of a building shall comply with all the applicable provisions for exit staircase, and

(b) Such exit staircase shall not be made continuous with any other exit staircase which serves a non-basement storey of the building, and

EXPLANATIONS & ILLUSTRATIONS

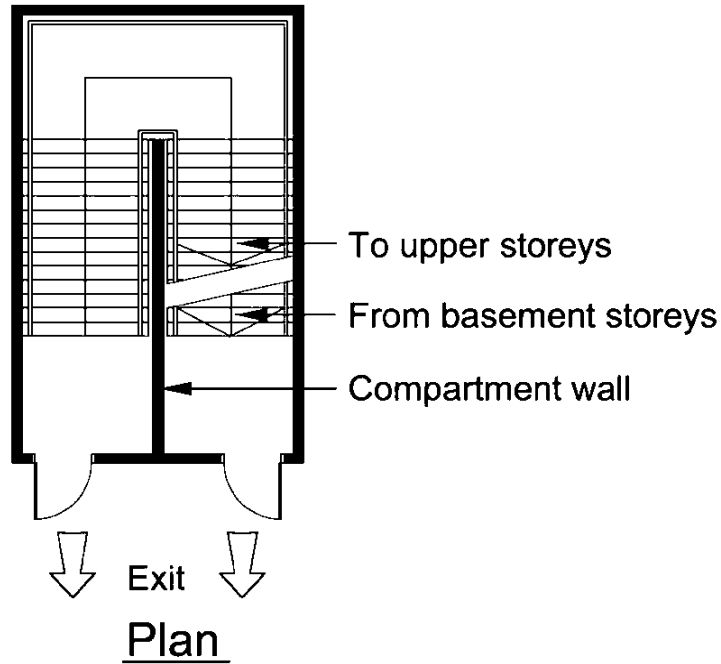

Diagram 2.3.5(b)



(c) Separate protected shaft

Basement exit staircases which are vertically aligned with the exit staircases of non-basement storeys shall be separated from such other exit staircases by construction having fire resistance for a minimum period equal to that required for the enclosure.

EXPLANATIONS & ILLUSTRATIONS

2.3.5

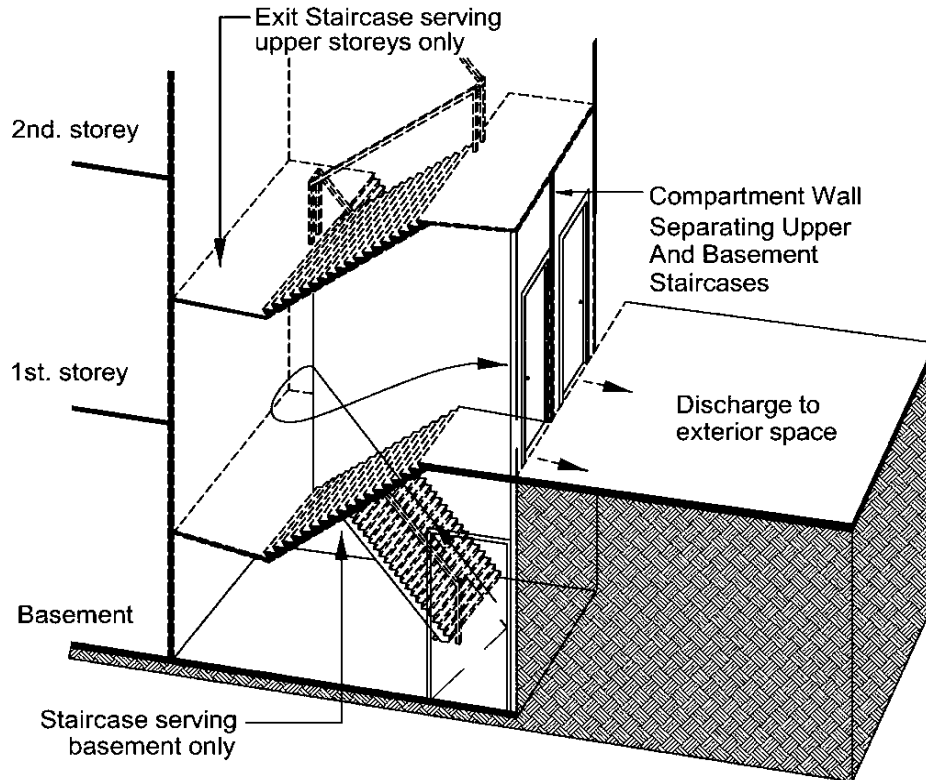

Diagram 2.3.5(c)

The provision of compartment wall is to separate the basement staircase from the non-basement staircase so that each is located in a separate shaft.



(d) Upper storey staircase continues into basement

Where upper storey staircase is allowed by the MFRS to be continuous with that serving the basement which is naturally ventilated, the following shall be complied with:

(i) Entry at basement

the entry into the basement staircase shall be through a protected lobby, or directly from the basement occupancy area provided the door to the basement staircase is minimum 1-hour fire rated;

(ii) Barrier

to prevent occupants exiting continuously from upper storeys into the basement storey during an emergency, a physical barrier in the form of a door or gate (self-closing type) could be provided across the staircase landing at ground level to separate the discharge route of upper storeys from the basement staircase;

(iii) Smoke-stop lobby

Smoke stop lobby shall be provided for entry into the staircase at all storeys, including basement if the staircase serves more than 4 storeys, including basement;

(iv) Signages

Appropriate signages shall be provided inside the staircase enclosure to direct occupants out of the building at ground level.

EXPLANATIONS & ILLUSTRATIONS

2.3.5(d) (ii)

Applicable only if staircase serves 4 storeys or less
and entry into the staircase from the basement carpark
is through a 1-hour rated fire door

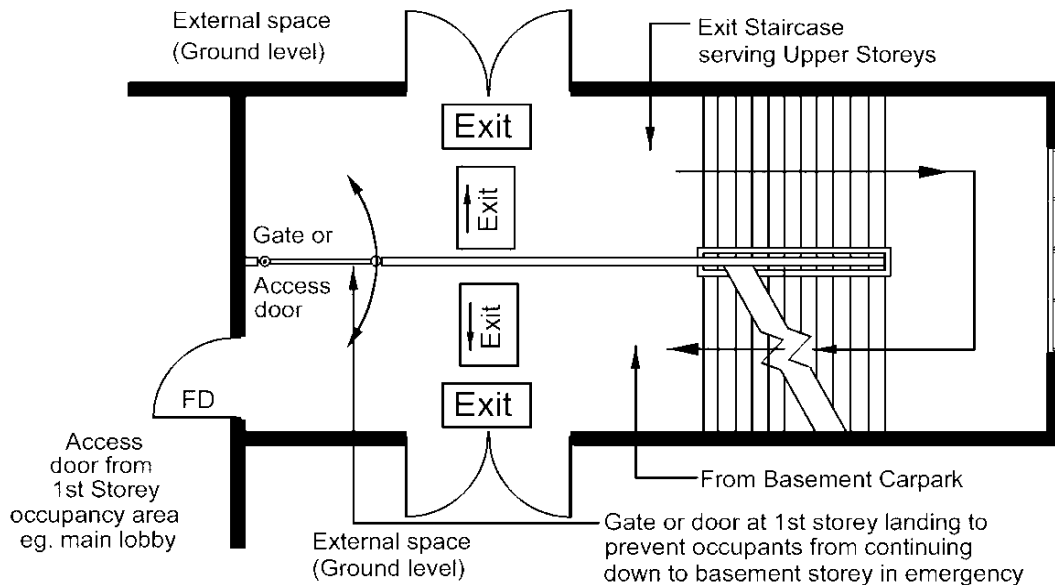

Plan

Diagram 2.3.5(d) (ii)

Interruption of Exit Stair at Level of Exit Discharge.

This can be done by placing a physical barrier, like the gate shown above, to prevent occupants from continuing to the basement in emergency. This, together with the aid of exit directional sign, helps to alert occupants in the stair enclosure that they are on the level of exit discharge.



CHAPTER 2

2.3 MEANS OF ESCAPE REQUIREMENTS - GENERAL

2.3.6 Hardwood staircase

- (a) Hardwood staircase shall be allowed to be used as internal access staircase in building.
- (b) Where timber staircases are used in units under Purpose Groups I and II buildings, which are not under conservation, the structural elements such as the stringer supporting the treads and risers shall be constructed of non-combustible materials.

EXPLANATIONS & ILLUSTRATIONS

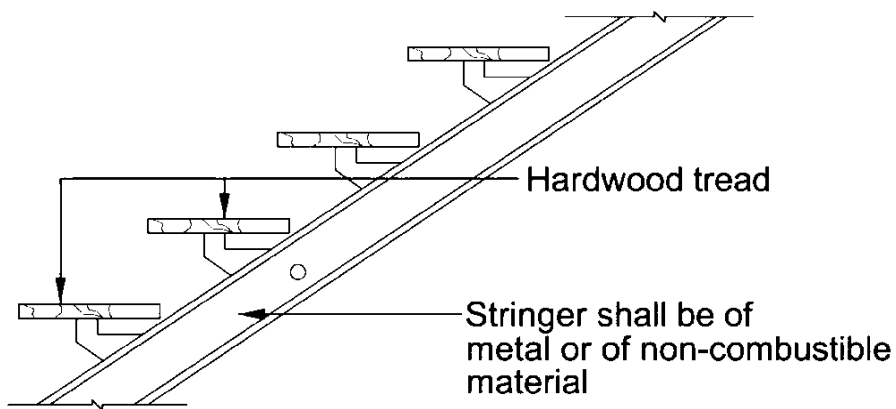

Unenclosed staircase

Diagram 2.3.6

As stringer is considered as part of an element of structure, it shall be of non-combustible material having the necessary fire resistance rating of 1/2 hour or 1 hour as the case may be under clause 3.3

Hardwood staircase is allowed to be used as internal access staircase.



CHAPTER 2

2.3 MEANS OF ESCAPE REQUIREMENTS-GENERAL

2.3.7 Spiral Staircase

- (a) Spiral staircases shall not serve as required exits except that external unenclosed spiral staircases when built of non-combustible materials and having a tread length of at least 750mm may serve as required exits from mezzanine floors and balconies or any storey having an occupant load not exceeding 25 persons, and
- (b) Such spiral staircases shall be not more than 10m high , and
- (c) Spiral staircase shall not be designed as the sole means of escape for buildings under Purpose Group I and maisonettes and penthouses for buildings under Purpose Group II.

EXPLANATIONS & ILLUSTRATIONS

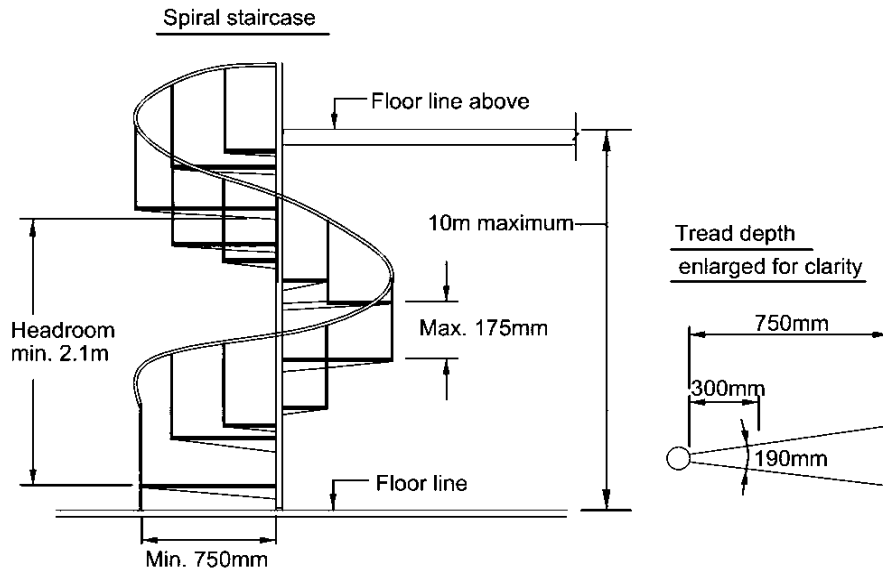

Tread depth enlarged for clarity

Diagram 2.3.7

Minimum and maximum dimensions for spiral stairs are shown above. All treads must be identical, and the stair can serve a maximum occupant load of 25 persons. Spiral staircase is slightly different from curved or other geometric staircases, as all its treads must be identical, subject to a height restriction of 10m and being located on the external facade of the building to qualify as exit staircase.

As spiral staircase is very steep and winding, the time taken by occupants to exit downwards during an emergency would be much longer, hence there is a need to limit the occupant load to max. 25 persons. In permitting the spiral staircase to be used as exit staircase in case of fire, and for rescue and fire fighting operations by fire fighters, the width of the staircase should not be less than 750mm. This width would be just adequate to permit movement of fire fighters in full body gear and carrying casualties in moving down the stair.



CHAPTER 2

2.3 MEANS OF ESCAPE REQUIREMENTS-GENERAL

2.3.8 Exit ramp

Internal and external exit ramps may be used as exits in lieu of internal and external exit staircases subject to compliance to the applicable requirements of Cl.2.3.3. and to the following:

- (a) The slope of such exit ramps shall not be steeper than 1 in 10, and
- (b) Exit ramps shall be straight with changes in direction being made at level platforms or landings only, except that exit ramps having a slope not greater than 1 in 12 at any place may be curved, and
- (c) Platform
 - (i) level platforms or landings shall be provided at the bottom, at intermediate levels where required and at the top of all exit ramps, and
 - (ii) level platforms shall be provided at each door opening into or from an exit ramp, and
 - (iii) the minimum width of a platform or landing and length shall be not less than the width of the ramp, except that on a straight-run ramp, the length of the level platform or landing need not be more than 1m, and

(d) Guards and handrail

Exit ramps shall have walls, guards or handrails and shall comply with the applicable requirements of Cl.2.3.3 (d) for exit staircases, and

(e) Surface

All exit ramps shall be provided with non-slip surface finishes, and

(f) Ventilation

Exit ramps shall be ventilated to comply with the requirements for ventilation of exit staircases, and

(g) Enclosure exemption

Exit ramps serving as means of escape to only one basement storey need not be protected by enclosure walls.



EXPLANATIONS & ILLUSTRATIONS

2.3.8(b)

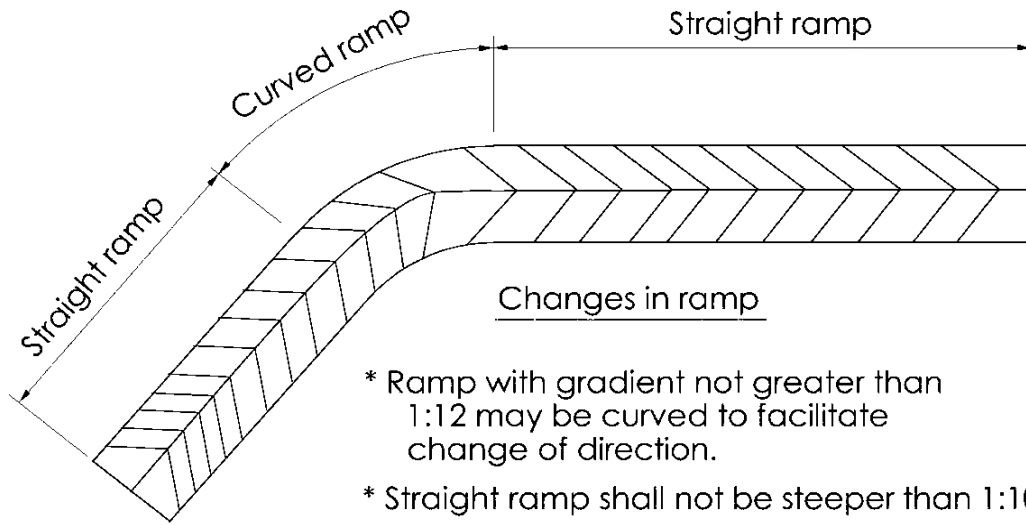

- * Ramp with gradient not greater than 1:12 may be curved to facilitate change of direction.
- * Straight ramp shall not be steeper than 1:10

Diagram 2.3.8(b)-1

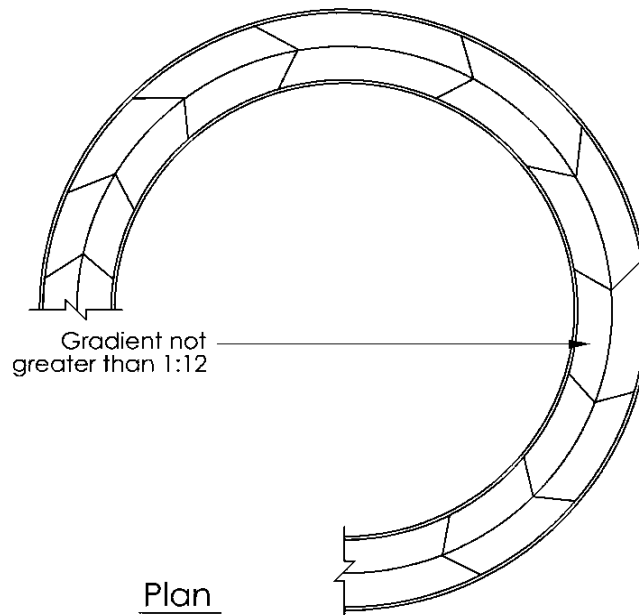

Diagram 2.3.8(b)-2

Circular ramp having a gradient not greater than 1:12 is acceptable as an exit ramp.

EXPLANATIONS & ILLUSTRATIONS

2.3.8

Length of ramp shall be at least 1m
and not more than 10m between landings

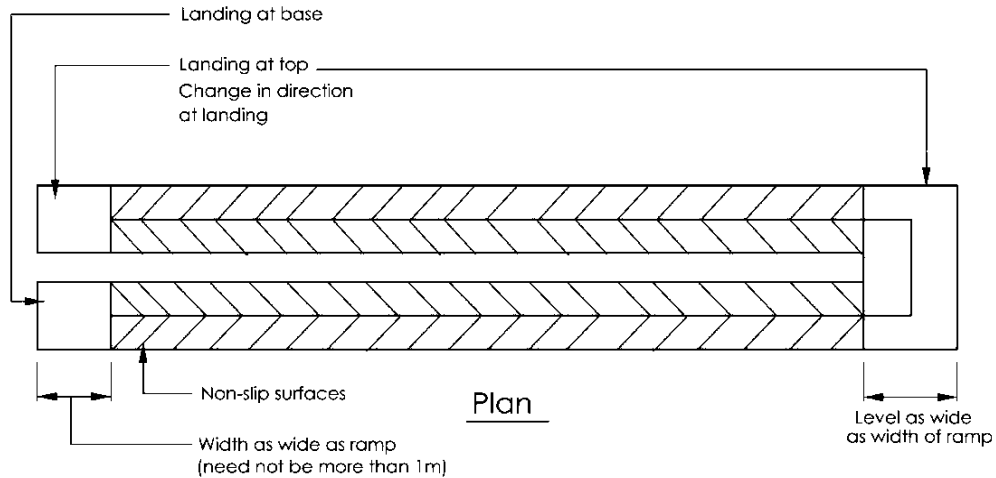

Diagram 2.3.8(c)

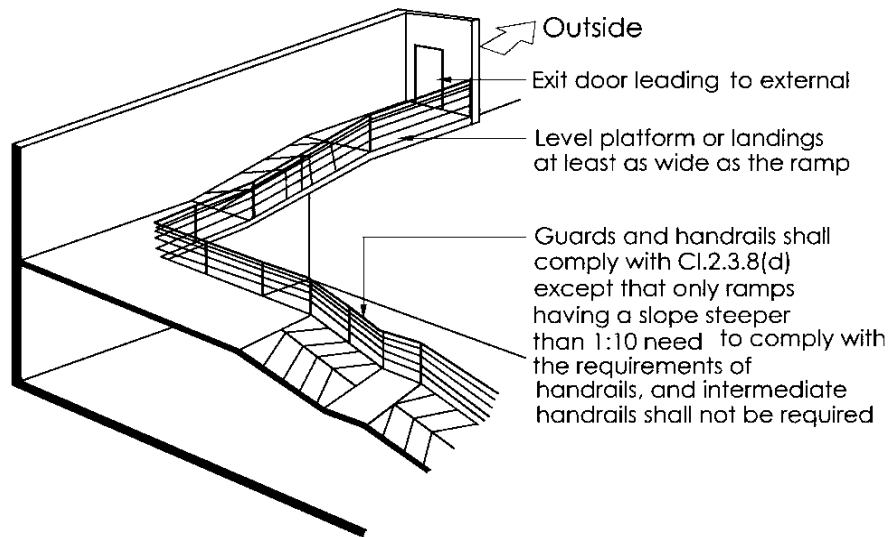

Diagram 2.3.8(d) & (g)

Occupants using the exit ramp would be able to travel at a quicker pace to exit directly into the exterior space at grade level. As only one level is involved and that final exit is within sight of exiting occupants, there is no need to protect the ramp with enclosure walls, provided travel distance is measured to the door at grade level and complies with Table 2.2A.

All exit ramps shall be constructed of non-combustible materials to have the necessary fire resistance rating as exit staircase. Similarly, the width of the exit ramp shall have the adequate exit capacity to receive the occupant load from the floor space it serves.



CHAPTER 2

2.3 MEANS OF ESCAPE REQUIREMENTS-GENERAL

2.3.9 Exit doors and Exit access doors

Exit doors and exit access doors shall comply with the following:

- (a) Exit doors shall be capable of being opened manually, without the use of a key, tool, special knowledge or effort for operation from the inside of the building; (not applicable to buildings under Purpose Group I & II) and
- (b) Exit doors which are required to have fire resistance rating shall comply with the relevant provisions for fire resisting doors under Cl.3.9.2; and
- (c) Exit doors and exit access doors shall open in the direction of exit travel:
 - (i) when leading to an area of refuge, exit and exit passageway, or
 - (ii) When used in exit enclosure, including smoke-stop and fire-fighting lobbies in a building. It shall not apply to doors of individual residential units that open directly into an exit enclosure, or
 - (iii) when serving a high hazard area, or
 - (iv) when serving a room or space with more than 50 persons, and
- (d) (i) Exit doors opening into exit staircases and exit passageways shall not impede the egress of occupants when such doors are swung open, and
 - (ii) All doors which open into the corridor shall not hinder movement of occupants. The corridor's clear width shall at least remain to be half of the required clear width as stipulated under Table 2.2A when such door(s) is swung open.

EXPLANATIONS & ILLUSTRATIONS

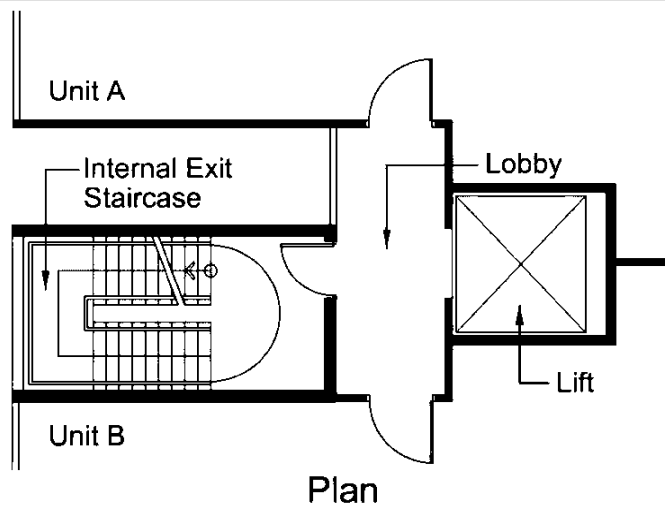

Diagram 2.3.9

EXPLANATIONS & ILLUSTRATIONS

2.3.9

Exit door opening into the exit staircase must satisfy the following requirements:

- (1) The dotted lines indicate the space that would be used by occupants exiting in the staircase.*
- (2) Exit doors to Industrial or warehouse units may open inward as shown in diagram 2.3.9 if the conditions mentioned above can be complied with. However they are normally constructed to open outwards due to it's usually larger than 50 occupant load.*
- (3) Exit doors which consist of 2 leaves, the smaller leaf is not required to be provided with sequential door closer if it is bolted in closed position and the clear width of opening of the larger leaf is not less than 850mm.*
- (4) Providing locking devices to exit door to exit staircase would hamper escape, unless there is other means of meeting both security and fire safety requirements. Usually, the final exit door of exit staircases at ground level are allowed to be provided with one-way locking mechanism for security reason, such as panic hardware or push bar opening devices.*
- (5) Provision of one-way locking devices hooked to the alarm system shall not be allowed unless otherwise permitted via waiver applications by the MFRS.*
- (6) In situations where the door of the industrial or warehouse unit opens directly into the staircase enclosure, there would be a need to provide locking devices to the door for security reasons.*

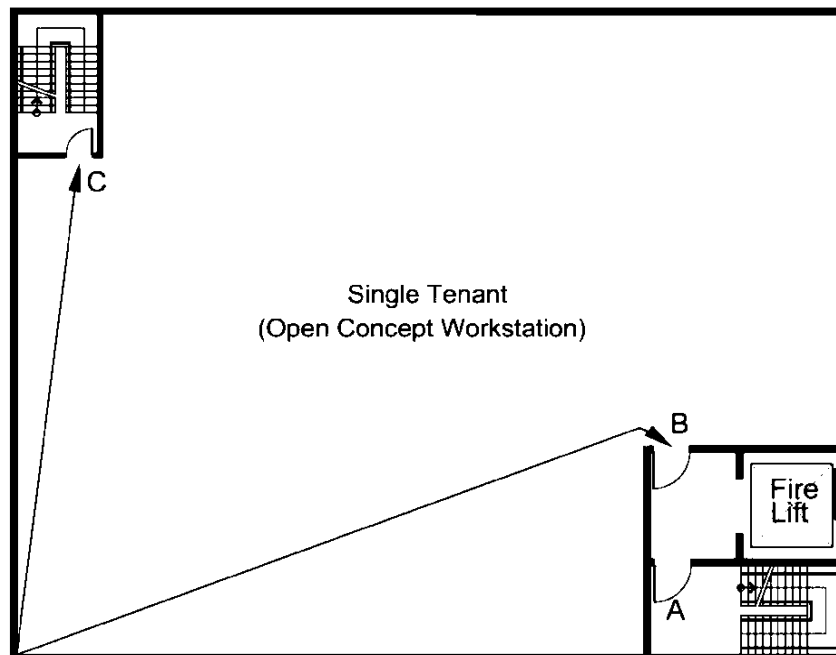

Door A One-way locking device is allowed, provided it is linked to the building's fire alarm system

Door B – C One-way locking device allowed (e.g. panic bolt, thumb turn or card access system with provision for unhindered exit in an emergency)

EXPLANATIONS & ILLUSTRATIONS

2.3.9

Multi-tenancy with no corridor

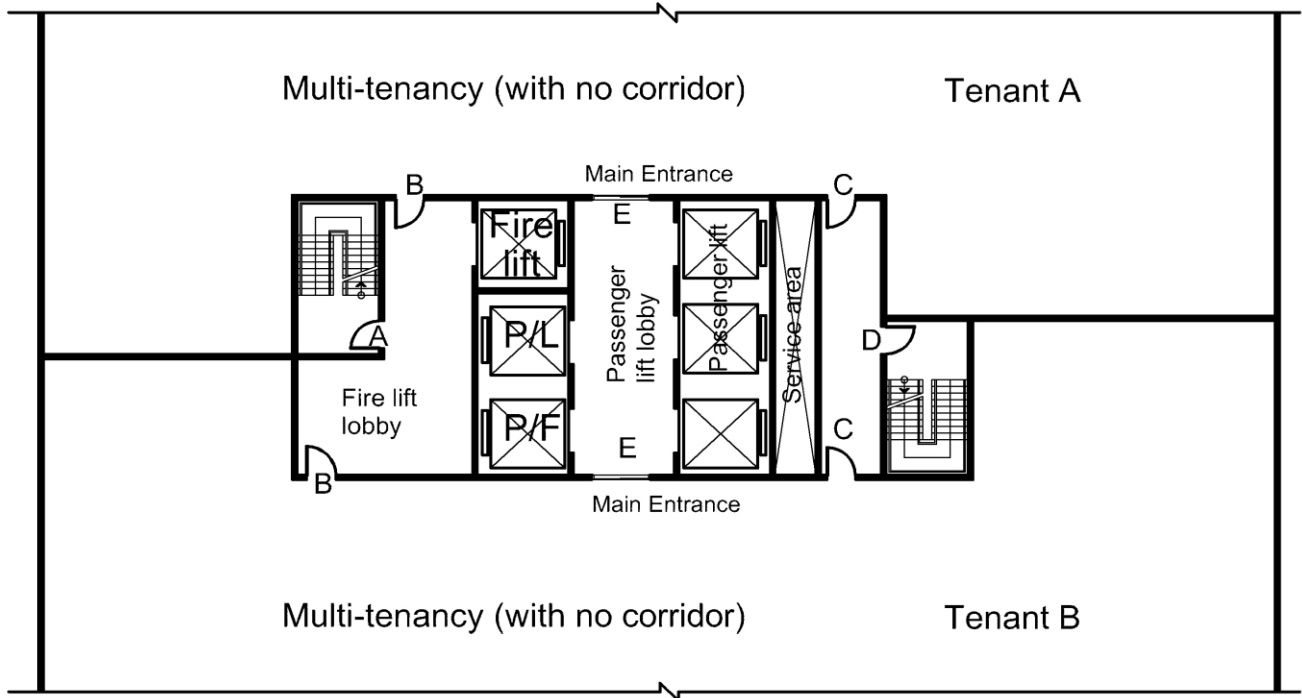

Diagram 2.3.9 –2

Doors A & D- One-way locking device allowed, provided it is linked to building’s fire alarm system. (e.g. panic bolt, thumb turn, card access system with provision for unhindered exit in an emergency)

Door B- One-way locking device allowed (door fitted with vision panel)

Door C- One-way locking device allowed

Door E- Locking device allowed, provided the fire wardens to ensure that persons stranded will be released and intercom system is linked to Fire Command Centre

EXPLANATIONS & ILLUSTRATIONS

2.3.9

Multi-tenancy with corridor

Diagram 2.3.9 –3

Doors A & B- One-way locking device allowed provided it is linked to building's fire alarm system

Door C- One-way locking device allowed (e.g. panic bolt, thumb turn or card access system with provision for unhindered exit in an emergency)

Door to fireman's staircase shall not be fitted with any form of locking device. This would facilitate the fire fighters to gain re-entry at any floor for the purposes of conducting fire fighting and rescue operations.

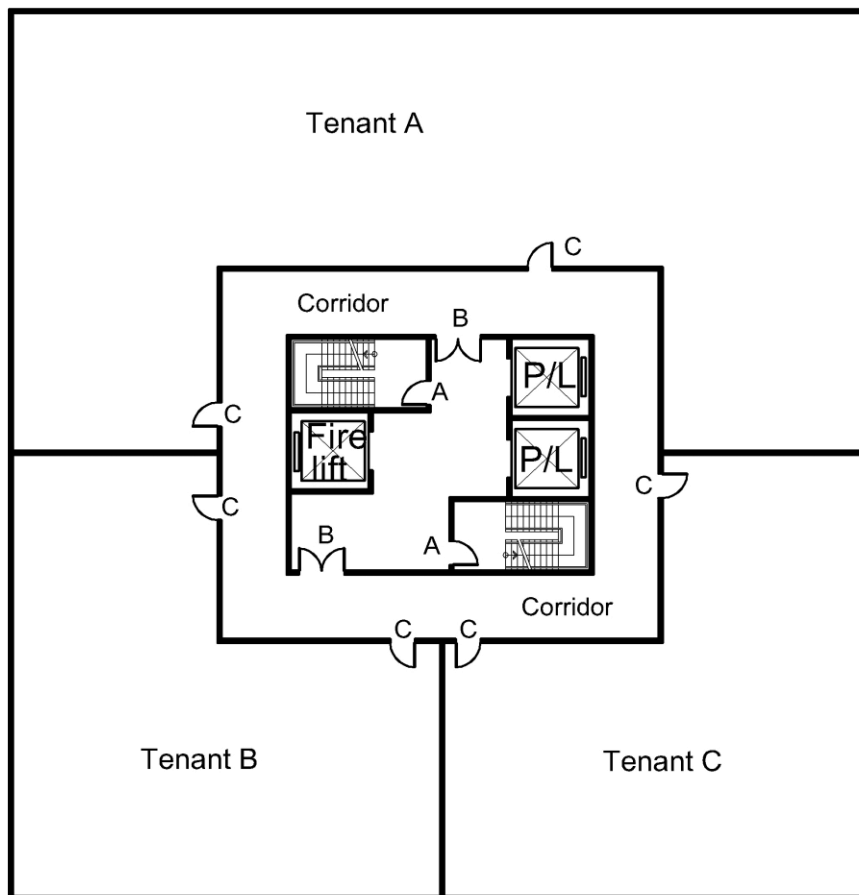
However, for security reasons, doors to fireman's staircase and selected re-entry doors to exit staircases are allowed to be fitted with one-way locking device that is linked to the building's fire alarm system. Upon activation of the fire alarm system, the locking device would be unlocked. It shall be a fail-safe system.

**EXPLANATIONS & ILLUSTRATIONS****2.3.9**

Exit door opening into the exit staircase must satisfy the following requirements:

- (1) Exit door opening into the exit staircase shall satisfy the requirements above. The dotted lines indicate the space that would be used by occupants exiting in the staircase.*
- (2) Exit doors to units A & B in the diagram 2.3.9 are shown to open inward. It is allowed if the exit door does not serve a room or space with more than 50 persons.*
- (3) Where an exit door consists of 2 unequal leaves, the smaller leaf may not be required to be provided with sequential closer if it is bolted in closed position, provided the clear width of opening of the larger leaf is not less than 1000mm, and able to meet the full exit capacity in terms of units of width required.*

(4) Doors on escape routes

Normally a door used for means of escape should open in the direction of escape. It should always do so: -

- (i) if it is from a room in which a fire may develop very rapidly e.g. kitchen etc.; or*
- (ii) if the door is from an area from which more than 50 persons may be required to escape e.g. exit doors to auditorium, multi-purpose hall function room, etc should be kept unlocked at all times when people are in the building and should be fastened so that they can be immediately opened by persons escaping without the use of a key. The door should be fastened only by means of panic bolt or panic bolt fastening which ensures that it can be readily opened by pressure applied by occupants using the door. Panic bolts and panic latches should be properly maintained at all times.*

(5) The door should also: -

- (i) be hung so that, when open, it does not obstruct any escape route;*
- (ii) open through not less than 90 degrees;*
- (iii) be provided with a vision panel if it is hung to swing both ways.*

(6) Self-closing devices for doors

All fire doors except those to cupboards and service ducts should be fitted with self-closing devices to ensure the positive closure of the door. Generally, rising butt hinges are not acceptable. Fire doors to cupboards, service ducts and any vertical shafts linking floors should be kept locked shut when not in use.



EXPLANATIONS & ILLUSTRATIONS

2.3.9

Not Acceptable

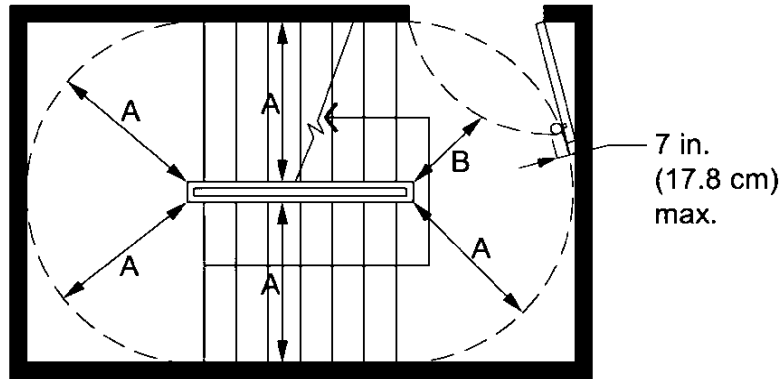

Diagram 2.3.9(d) (i)

Doors serving as main entrance into an enclosed stair should not unduly block the stair landing or the stairs. Ideally, the door would not reduce the required width either during its swing or while at rest.

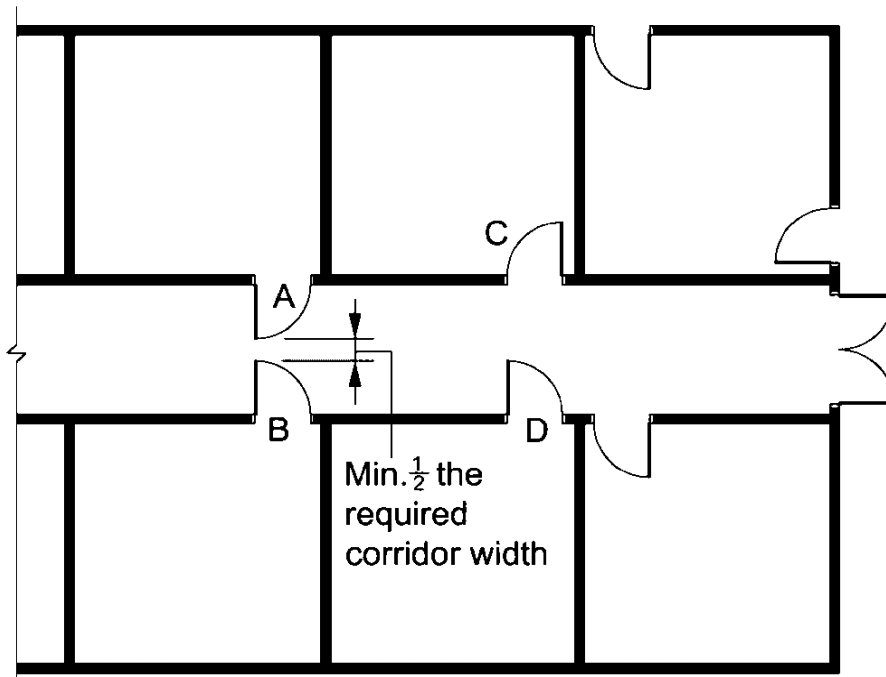
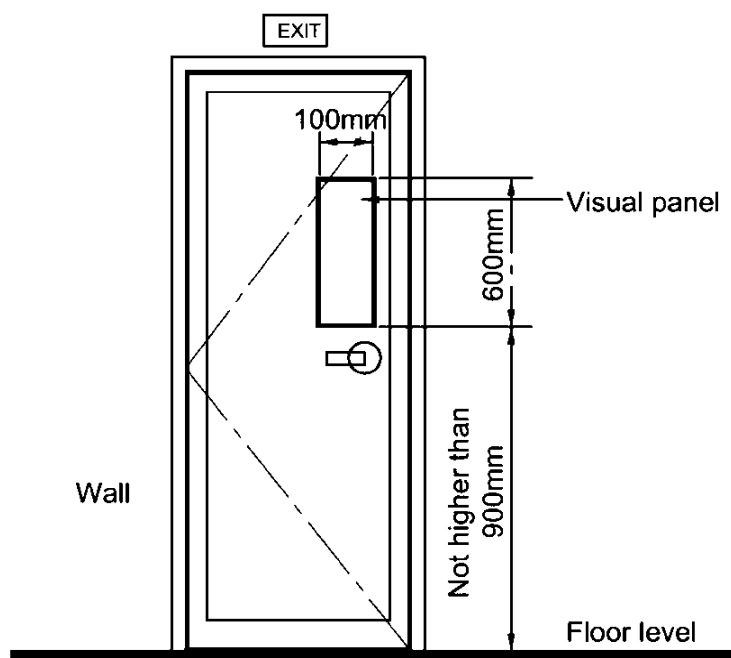

Diagram 2.3.9(d)(ii)

Doors in horizontal exits shall not be required to swing in the direction of egress travel if the occupant load within the unit space is less than 50 persons.

Doors A & B are positioned directly each other. It is to be noted that doors shall not be arranged to swing in a direction that blocks the use of the corridor when both are open.

- (e) Fire door to protected staircase and smoke-stop/fire lift lobby shall be constructed to incorporate a vision panel. The vision panel shall have a clear view size of 100mm width by 600mm height. The vision panel shall have the requisite fire resistance rating and shall not turn opaque when subject to heat. The vision panel shall be located with the bottom edge not higher than 900mm and the top edge lower than 1500mm measured from the finished floor level. The provision of vision panel shall not apply to exit doors of residential apartment or maisonette units.

EXPLANATIONS & ILLUSTRATIONS
2.3.9

Diagram 2.3.9(e)

- (1) Fire doors with vision panels 60,000 m² shall pass the fire test under BS 476.
- (2) Fire rated glass doors shall only be permitted in sprinklered protected buildings. In addition, any oversized (>30,000 mm²) glass panels in the doors and fire rated glass doors shall meet the Class A of the Impact Performance requirements when subject to test under BS 6206. To overcome direct heat radiation through the doors, the oversized glass doors or fire rated glass doors would be required to pass the fire test on insulation requirements under BS 476, subject to complying with clause 3.15.13, which prohibits fire rated glass door to protected shafts containing exit staircase and fire lift. The lowering of vision panel to height not higher than 900mm and top edge lower than 1500mm is in line with the Accessibility Code requirement and enable fire fighter to appreciate the situation during a fire emergency.

There is no need to provide vision panel to the entrance door of residential units.



(f) Revolving doors shall not be used as exit doors for required exits.

EXPLANATIONS & ILLUSTRATIONS

2.3.9

No illustration.

Revolving doors are not acceptable as exit door as the revolving mechanism would mal-function and the speed of egress is slow.

Due to the risk of jamming, conventional type of revolving doors are not normally allowed as doors for means of escape purposes. Where such door is used, exit door must be clearly indicated with exit sign.



(g) Exit door of each residential unit shall be located at not more than 500mm from the strata-title line to prevent the creation of large entrance alcove/corridor. However, in situation where the entrance alcove/corridor leads into an open sided common corridor which meets the requirements for smoke free approach under Cl.2.4.8, the separation distance between the entrance alcove/corridor and the nearest exit staircase shall not be less than 3000mm.

EXPLANATIONS & ILLUSTRATIONS

2.3.9

Not Acceptable

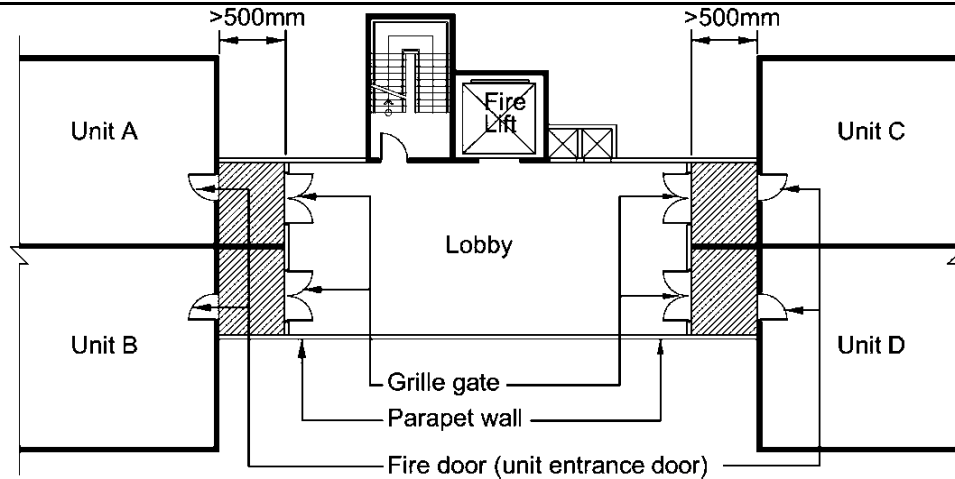

Plan

 Entrance alcove/corridor having a depth of more than 500mm, measured between the entrance door of the unit and the grille gate

Diagram 2.3.9(g)-1

Acceptable

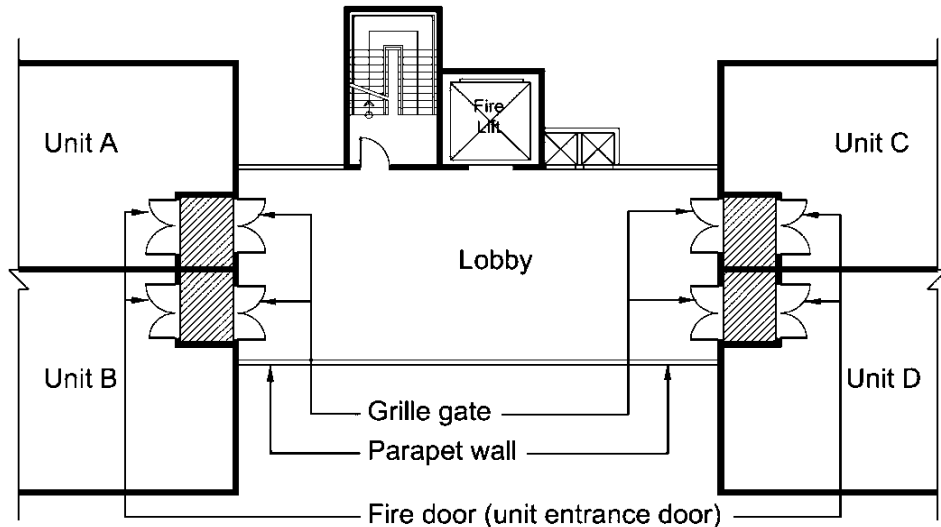

Plan

 Entrance alcove/corridor having a depth of 500mm or less measured between the entrance door of the unit and the grille gate

Diagram 2.3.9(g)-2



EXPLANATIONS & ILLUSTRATIONS

2.3.9(g)

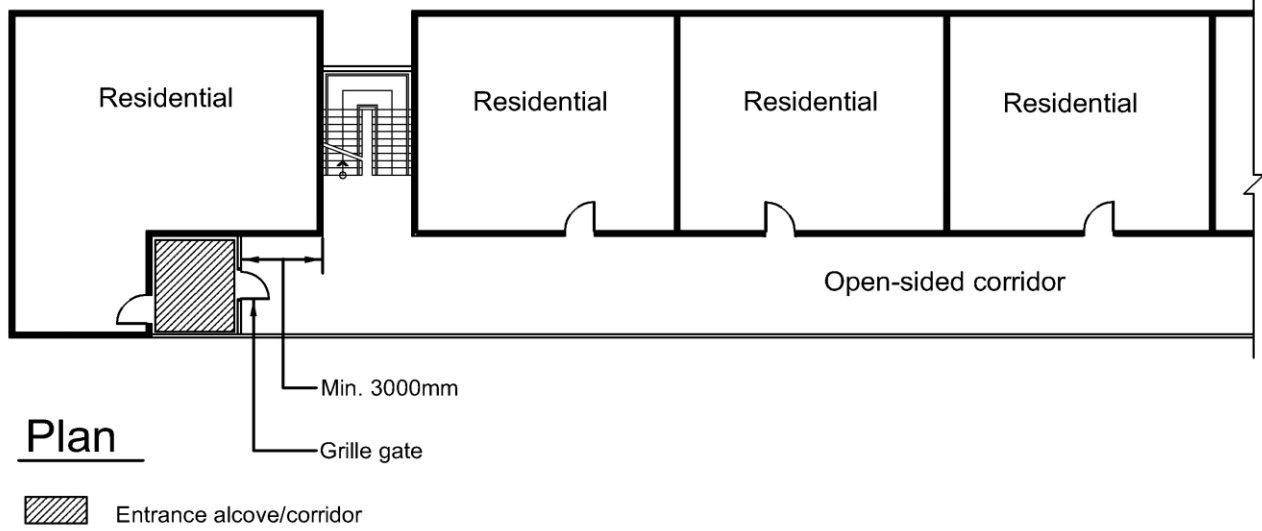

Diagram 2.3.9(g)-3

Separation distance between grilles/gate and exit staircase shall not be less than 3000mm.



(h) Any door located in a path of travel shall be of the side-hinged or pivoted swing type. The door shall be designed and installed so that when swung open, it does not prevent full use of the opening. The minimum clear width of the door opening shall not be less than the required door clear width.

Exception 1: Requirement on door swing shall not apply to buildings under Purpose Group I and residential units under Purpose Group II.

Exception 2: With prior consent from the MFRS, locking of exit doors is permissible at certain rooms or spaces of health care occupancies and detention and correctional occupancies.

Exception 3: Sliding door and roller shutter as listed in (i) to (iv) are permitted to be installed across the exit access or escape paths leading to exits, including the exterior door openings except in areas stipulated under cl.2.3.9(c)(i) and (iii). These doors shall not form part of the fire compartment integrity.

Note:

2.3.9(c) (i) - when leading to an area of refuge, exit and exit passageway, or 2.3.9(c)(iii)- when serving a high hazard area

Manually operable sliding doors or roller shutters shall be capable of being opened and closed manually from either side of the door. The maximum door opening force shall be 30N at 0 deg and 20N at 30 deg opening.

EXPLANATIONS & ILLUSTRATIONS

2.3.9

No illustration.



(h)(i) Manually operable sliding door or roller shutter that can remain in closed position during the period of occupation is permitted at rooms or spaces with occupant load not exceeding 50 persons. When opened, it shall not reduce the effective width/height of the doorway leading to the escape route. Sliding door or roller shutter is allowed within rooms or spaces that serve more than 50 persons provided it shall remain in the full open position during the period of occupation. A readily discernible sign with the lettering “THIS DOOR TO REMAIN OPEN WHEN THE BUILDING IS OCCUPIED” shall be permanently pasted on both sides of such sliding door or roller shutter at a height of 1.4 m from the finished floor level. The lettering shall be 25mm in height and painted in white on a red background with reflective surface, or

EXPLANATIONS & ILLUSTRATIONS**2.3.9**

No illustration.

If the occupant load to a room or space exceeds 50 persons, sliding door or roller shutter located across means of escape shall be kept in the open position during the period when the premise is occupied. The main concern is that extra effort and time would be needed to manually open the roller shutter or sliding door. Alternatively, wicket door can be built into the roller shutter or sliding door.

For warehouse buildings, most of the time the warehouse area would not be occupied unless there is a need to move goods or materials in or out of the building. Also, the actual number of people occupying a warehouse is usually very low.

For the above reasons, when the warehouse area is occupied, selected roller shutters or sliding doors that are not provided with wicket doors and located across means of escape would be kept in the open position to provide the required means of escape in an emergency.

However, should any warehouse building be open to the public for the purpose of Warehouse Sale, all the roller shutters or sliding doors, that are not fitted with wicket doors and located across the means of escape in the warehouse area, are required to be kept in the open position when the premise is occupied.

In areas provided with A/C or M/V and the roller shutters or sliding doors are required to be kept in the closed position most of the times, wicket doors shall be incorporated into the roller shutters or sliding doors. Alternatively, a by-pass exit door shall be provided next to the roller shutter or sliding door that is to be kept in the closed position most of the times.

All roller shutters or sliding doors that are not provided with wicket doors and located across means of escape are required to be kept in the open position when premise is occupied.

- (h)(ii) Wicket door shall be permitted to be incorporated within a roller shutter or sliding door. The wicket door shall be of the swing type having a minimum head height of 2m and a clear width of not less than the required door clear width. The wicket door shall comply with all the requirements of exit access door, and be clearly marked and readily visible so that the occupants can readily see where the door is. It should be fitted only with simple fastenings that can be manually operated for ease of escape, or
- (iii) A sliding door which can be swung open, shall swing in the direction of escape travel when a certain horizontal force is applied to the door. When the sliding door is converted to a swing door, it shall comply with all the requirements of an exit access door. The maximum door opening force shall be 30N at 0 deg and 20N at 30 deg opening. A readily visible sign with the letterings “IN EMERGENCY, PUSH TO OPEN” shall be affixed onto the door, or

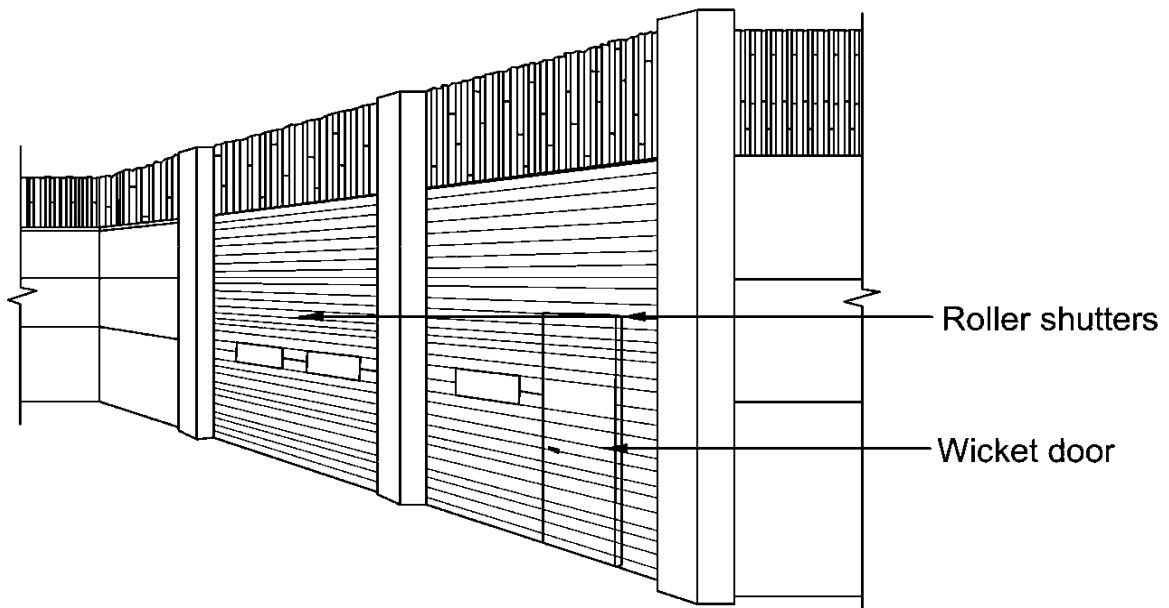
EXPLANATIONS & ILLUSTRATIONS**2.3.9***Diagram 2.3.9(h)(ii)*

Wicket doors are permitted to be incorporated within a roller shutter or sliding door. The wicket doors shall be able to perform the same functions as side hinged door and shall be able to be swung open in the direction of exit travel when used. Wicket doors shall comply with all requirements of exit access door, clearly marked and readily visible.



(h)(iv) Power operated automatic sliding doors/ roller shutters, shall be linked to the building fire alarm system. The sliding door/ roller shutter shall automatically open to the required width/height (of door opening) upon the activation of the fire alarm. The automatic sliding door/ roller shutter shall also comply with the following:

- (1) The automatic sliding doors/ roller shutters shall be of the fail-safe type. Should there be any fault in the electrical or sensor device, or any power failure (either mains or battery powered), these doors shall automatically open and remain in an open position until power is restored.
- (2) A manual override mechanism (a device to trigger the immediate opening of sliding doors/ roller shutters) shall be provided. The doors shall open and remain open upon activation of this device. This device shall be housed in a break glass box located beside the sliding doors or roller shutters and fixed at a height of 1.4m above the finished floor level. It shall be easily accessible, conspicuous and be free from obstructions. A readily discernible sign with the lettering “EMERGENCY DOOR RELEASE” shall be permanently pasted beside the switch. The letterings shall be of at least 15mm in height.

Exception : Powered sliding doors, roller shutters and swing doors that belong to the unit owners or tenants are not required to be linked to the building fire alarm system, provided they are designed as fail safe type, installed with manual over-ride, and do not form part of the building’s fire protection system, for example, smoke control system

EXPLANATIONS & ILLUSTRATIONS

2.3.9

No illustration.

With immediate effect, powered sliding doors, roller shutters and swing doors that belong to the unit owners or tenants are not required to be linked to the building fire alarm system, provided that they are designed fail safe type, installed with manual over-ride, and do not form part of the building’s protection system, for example, smoke control systems.



- (i) Any exit door or exit access door serving spaces of assembly/mass occupation, such as auditorium, concert hall, theatre, assembly hall, exhibition hall, cinema, etc which has to be kept shut and fastened while the building or part of the building is occupied shall be fitted with ‘panic exit device.’. The panic exit device shall operate to open the door when a pressure is applied on the bar in the direction of travel and be appropriately marked ‘Push Bar To Open’ in letters not less than 50mm high.

EXPLANATIONS & ILLUSTRATIONS

2.3.9

No illustration.



(j) Locking of staircase and smoke stop/fire lift lobby doors

One way locking device is allowed to be provided to doors of exit staircase, smoke stop/fire lift lobby in the following situations, provided only one-way locking device is used, e.g. panic bolt or thumb turn locking device:

- (i) exit door between staircase shaft and occupancy area; and
- (ii) exit access door between smoke-stop/fire-fighting lobby and occupancy area; and
- (iii) exit door between staircase shaft and smoke-stop lobby; and
- (iv) exit door between staircase shaft and circulation area; and
- (v) exit access door between smoke-stop/fire-fighting lobby and circulation area.

For selected floors under sub clause 2.3.9(1), the doors of the fire-fighting/exit staircase and smoke-stop/fire-fighting lobby shall not be fitted with any locking device to allow for re-entry from the staircase to the interior of the building.

EXPLANATIONS & ILLUSTRATIONS

2.3.9

No illustration.



- (k) Where access-control is provided to exit door using smart card locking device, magnetic bar and electro-mechanical locking device :
 - (i) The activation of the building fire alarm or sprinkler system shall automatically unlock the door. It shall remain unlocked until the building fire alarm system has been manually reset; and
 - (ii) The door shall be arranged to unlock from a manual release device located within the occupancy space, 1200mm above the floor and within 1.5m of the exit door jamb. The manual override device shall be readily accessible and clearly identified by a sign that reads “Emergency Door Release”. The mechanism to unlock the door shall be fail-safe type.
 - (iii) Where doors opening into passenger lift lobby are to be provided with access-control and would be locked after normal operation hours, the lobby shall be designed to have direct access to at least one exit staircase to prevent any occupant from being trapped in the lobby when the lifts are recalled at 1st storey or other designated floor during fire emergency or building’s power failure. Alternatively, a two-way communication system shall be available inside the lift lobby for use by trapped occupants to call for help. The two-way communication system shall be linked to the fire command centre and/or building control room which shall be manned 24 hours

EXPLANATIONS & ILLUSTRATIONS

2.3.9

No illustration.

(l) Staircase re-entry

- (i) Every exit staircase enclosure serving more than 7 storeys of non-residential building, excluding buildings of detention and correctional occupancies, shall allow re-entry from the staircase enclosure to the interior of the building. There shall be at least 1 level where it is possible to re-enter into the interior of the building from the staircase enclosure.
- (ii) The re-entry points shall be located not more than 6 storeys apart. There shall not be more than 3 storeys above the highest re-entry door in the building.
- (iii) Where re-entry is provided from the staircase enclosure, it shall enter into a common corridor that is connected directly to at least one other exit staircase
- (iv) Staircase doors permitting re-entry into the building, shall be identified with a signage “Re-entry door” of min. 50mm lettering height on the staircase side of the staircase door.

Note: Where the doors of exit staircases, smoke-stop lobbies or fire -fighting lobbies are provided with one-way locking device or electro-mechanical lock, a signage, though not mandatory, should be provided to warn occupants that they would not be able to re-enter the floor should they exit from it. The signage should be positioned at the entrance into exit staircase, smoke-stop lobby or fire-fighting lobby.

EXPLANATIONS & ILLUSTRATIONS

2.3.9

Example of a 9-storey building requiring 1 re-entry point to the exit staircase

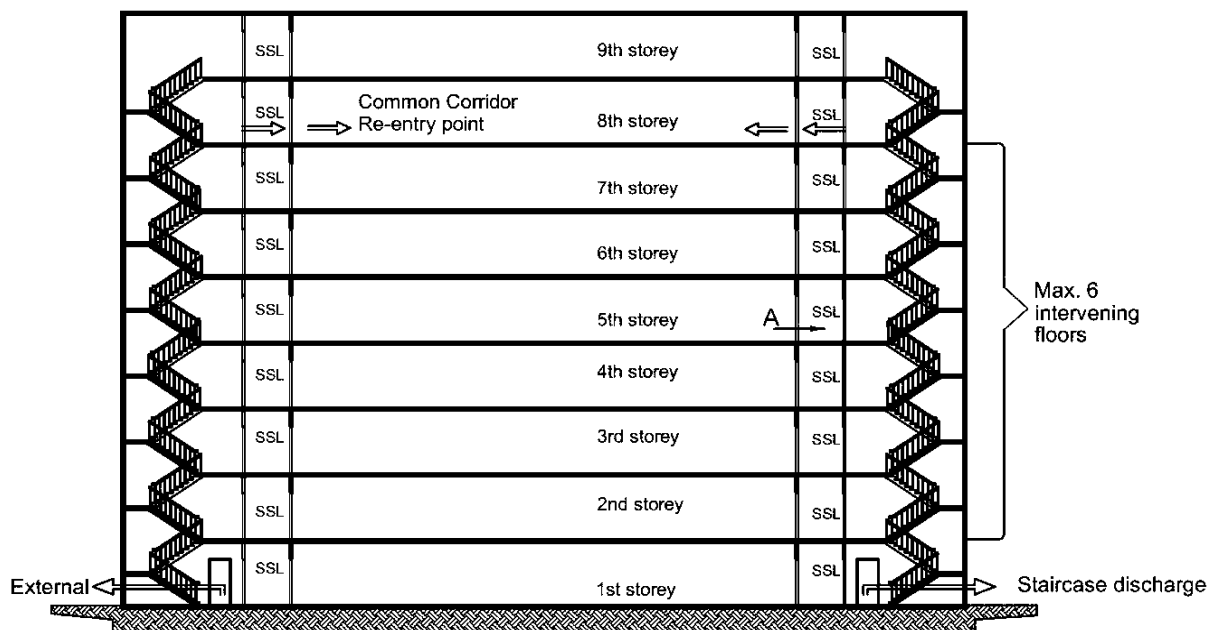

Diagram 2.3.9(l)-1

Occupant A, needs not travel more than 3 floors up to gain re-entry at 8th storey. The main purpose of re-entry door is to allow occupants to re-enter the building space to look for an alternative exit via a common corridor. This need would arise if the evacuation descend in the staircase is being held-up because of locked exit door at 1st storey or other reasons.



EXPLANATIONS & ILLUSTRATIONS

2.3.9

Example of a 10-storey building requiring 1 re-entry point to the exit staircase

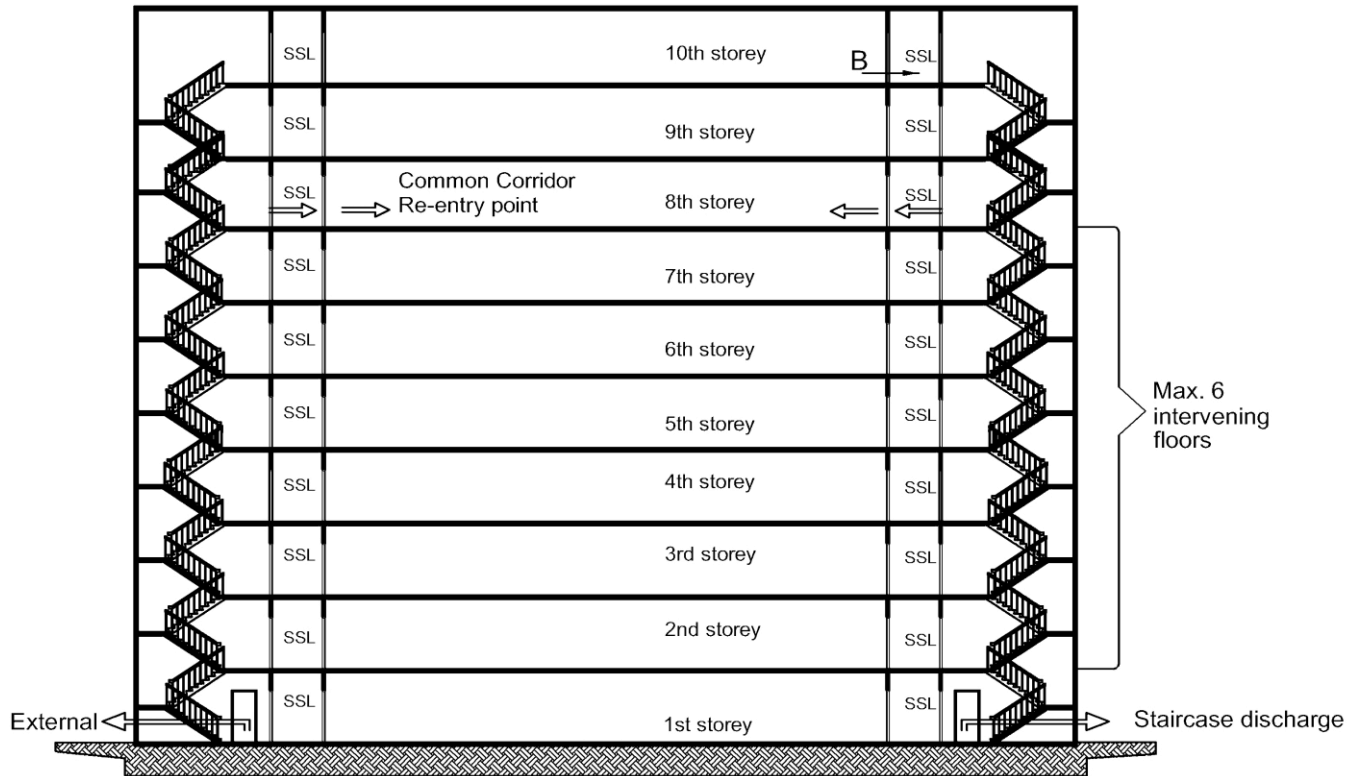

Diagram 2.3.9(1)-2

Occupant B, needs to travel 2 floors down to gain re-entry at 8th storey



EXPLANATIONS & ILLUSTRATIONS

2.3.9(i)

Example of a 11-storey building requiring 1 re-entry point to the exit staircase

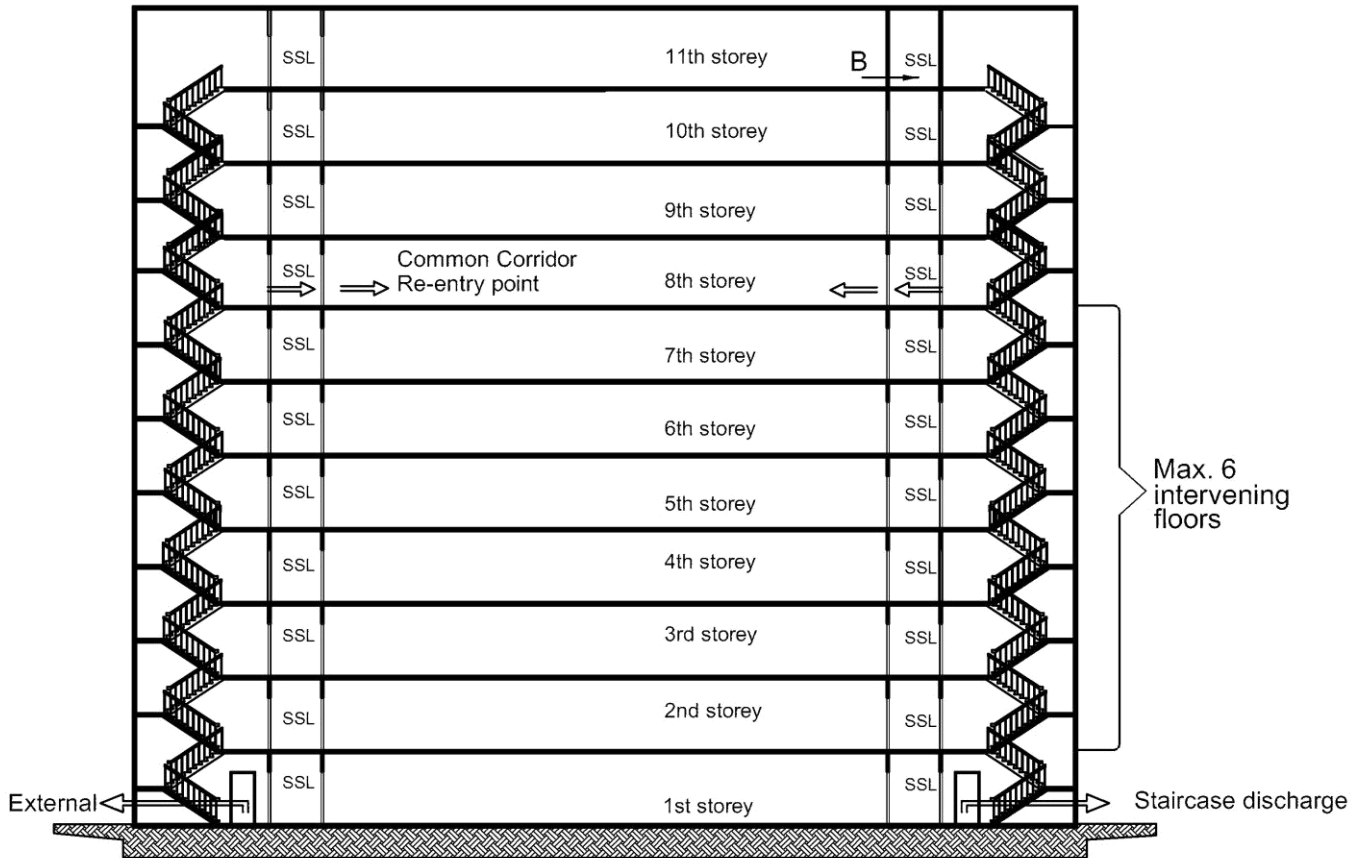

Diagram 2.3.9(i)-3

Occupant B, needs to travel not more than 3 floors down to gain re-entry at 8th storey

EXPLANATIONS & ILLUSTRATIONS

2.3.9(I)

Example of a 12-storey building requiring more than 1 re-entry point to the exit staircase

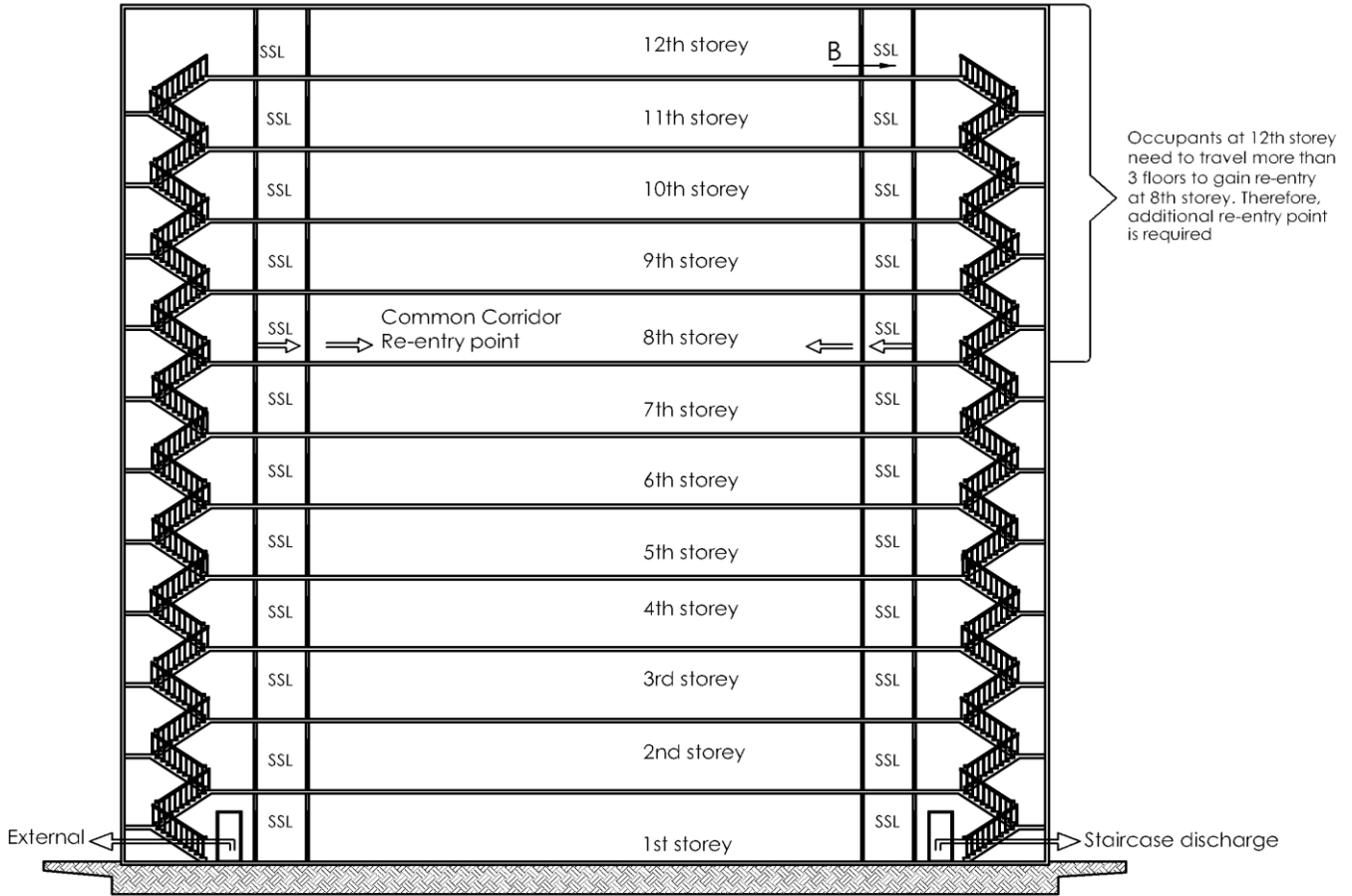

Diagram 2.3.9(I)-4

Occupant B, needs to travel more than 3 floors down to gain re-entry at 8th storey. An additional re-entry point to each exit staircase shall be provided.

EXPLANATIONS & ILLUSTRATIONS

2.3.9(l)

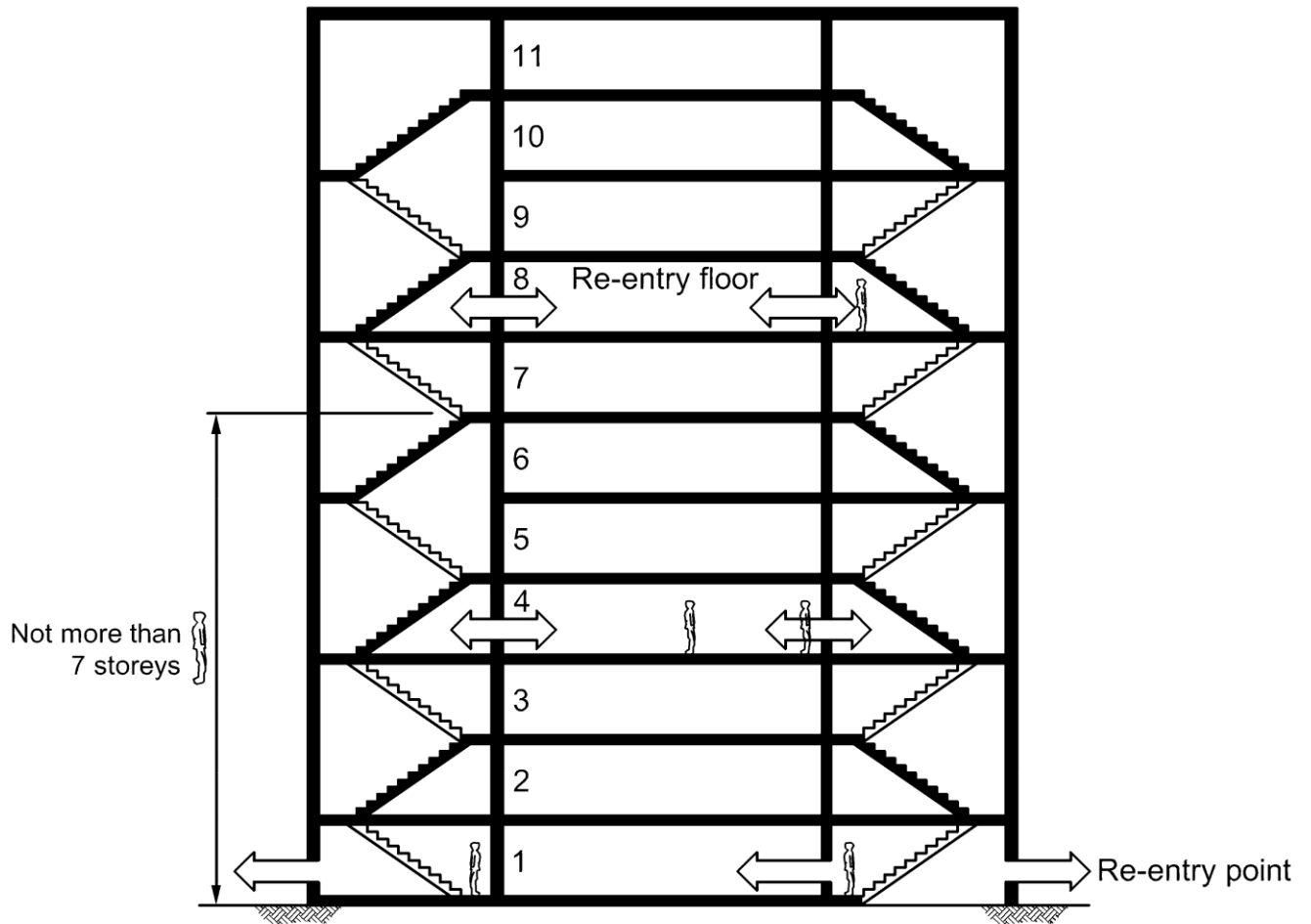

Diagram 2.3.9(l)-5

For stair enclosures serving more than seven storeys, more than two unlocked re-entry points are required. This arrangement provides flexibility, especially in office buildings that, for security reasons, might need to prevent re-entry on certain floors. At the same time, the provision ensures that one can re-enter the building without having to travel up or down too many flights of stairs. Any door providing a way out of the stair enclosure must be identified as such on the stairwell side.



EXPLANATIONS & ILLUSTRATIONS

2.3.9(1)

Staircase Re-entry Floor

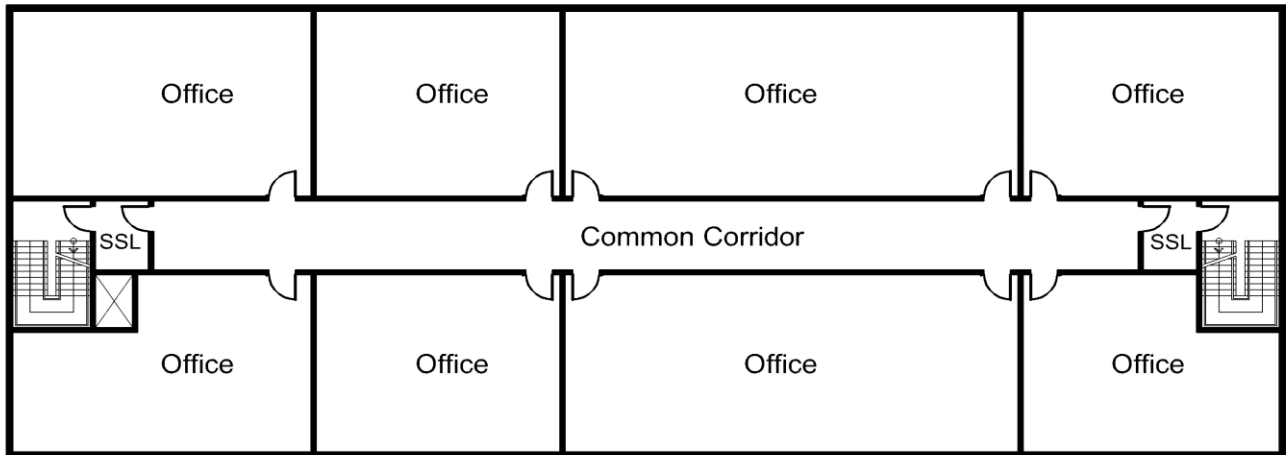

Diagram 2.3.9(1)-6

Typical office floor plan – Staircase doors that provide re-entry to the floor space shall be linked to at least one other exit staircase via common corridor.

CHAPTER 2

2.4 RESIDENTIAL OCCUPANCY

2.4.1 Residential buildings of Purpose Group I

Means of escape for a building or a separate part of a building of single occupancy of Purpose Group I may be provided via access staircases, and exit staircase under the provision of Cl.2.3 is not required.

EXPLANATIONS & ILLUSTRATIONS

Buildings which exceed 3 storeys or levels, inclusive of attic and basement but not exceeding 4 storeys or levels are not required to comply with either the provision of an automatic fire alarm system or the provision of an external exit staircase to serve the topmost storey or level. See diagram 2.4.1-1 and 2.4.1-2, subject to complying with the clear width of staircase and corridor as mentioned in clause 2.2.1.

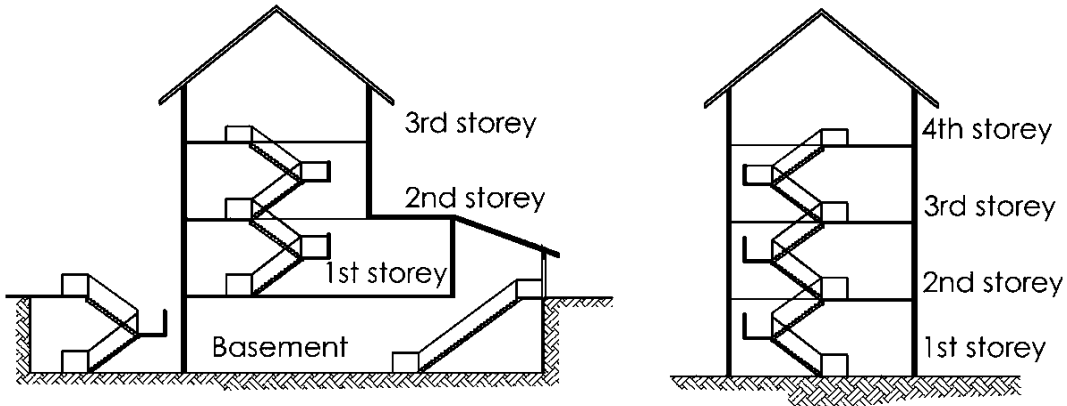

Diagram 2.4.1-1

Unenclosed internal staircase serving as means of escape for the building

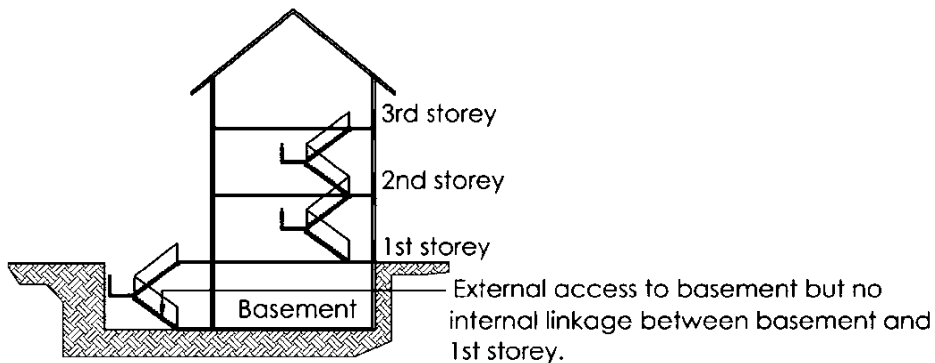

Diagram 2.4.1-2

An alternative arrangement to fire separates the basement from upper storeys. For roof terrace, see Cl.3.14.4. Basement level shall be compartmented and separated from upper storeys such that discharge shall be directly to external space



CHAPTER 2

2.4 RESIDENTIAL OCCUPANCY

2.4.2 Residential buildings of Purpose Group II	
<p>Means of escape for a building or a separated part of a building of Purpose Group II shall comply with the provision of Cl.2.3.</p>	
EXPLANATIONS & ILLUSTRATIONS	
<p><i>No illustration.</i></p>	



CHAPTER 2

2.4 RESIDENTIAL OCCUPANCY

2.4.3 No of exit staircases or exits per storey

In a block of residential apartments or maisonettes, at least two independent exit staircases or other exits from every storey shall be provided in compliance with the requirements of Cl.2.2.11 unless otherwise permitted.

EXPLANATIONS & ILLUSTRATIONS

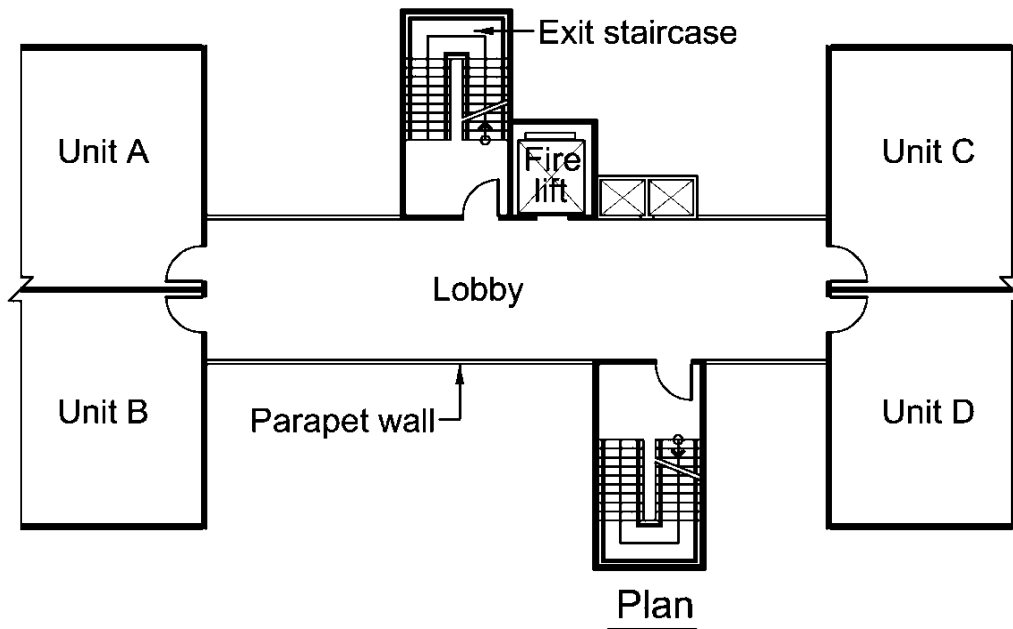

Diagram 2.4.3

The provision of two remotely located staircases or other exits provides for alternate escape for the occupants if one staircase or alternate exit is blocked off or rendered unusable in an emergency situation.

CHAPTER 2

2.4 RESIDENTIAL OCCUPANCY

2.4.4 Provision for buildings not exceeding 24m in habitable height

In a block of residential apartments or maisonettes not exceeding 24m in habitable height, one exit staircase only may be allowed to serve every upper storey, subject to:

- The exit staircase shall comply with the requirements of Cl.2.3.3.
- If the building consists of more than four storeys, approach to the exit staircase on all storeys shall comply with the requirements of smoke free approach to exit staircase under Cl.2.2.13.
- Access to the building for fire-fighting appliances being provided for in compliance with the requirements in Chapter 4.

EXPLANATIONS & ILLUSTRATIONS

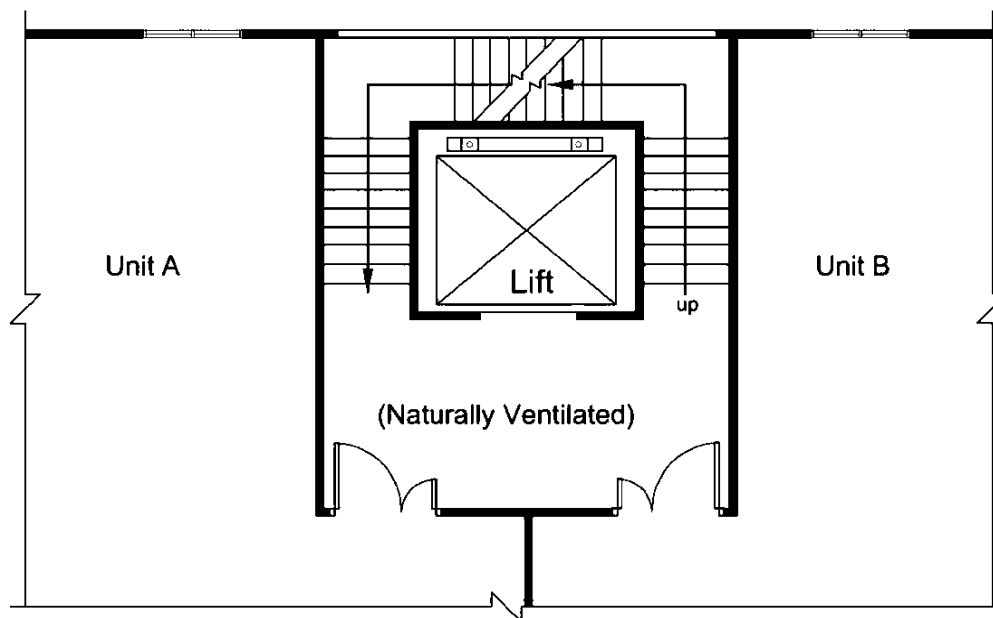

Plan

Diagram 2.4.4-1

Single staircase is only permitted for buildings not exceeding 4 storeys as the exit staircase is not separately enclosed. The above diagram shows a protected lift shaft, which is wrapped around by an exit staircase.

The space between the entrance doors and the lift shaft serves as a staircase landing, lift lobby and entrance to the residential units. It is not considered as a smoke stop lobby. Buildings, which are not more than 4 storeys, are not required to be provided with smoke stop lobby. Instead, the residential units have direct entry into the staircase enclosure.

EXPLANATIONS & ILLUSTRATIONS**2.4.4**

The above arrangement, with or without a protected lift shaft, is not acceptable for buildings exceeding 4 storeys.

The above arrangement is also not acceptable if the staircase is fully enclosed and provided with mechanical ventilation. The reason is that the movement of the lift car could cause a 'piston effect' to push or draw smoke into the staircase should a fire occur in the lift car or any of apartment units.

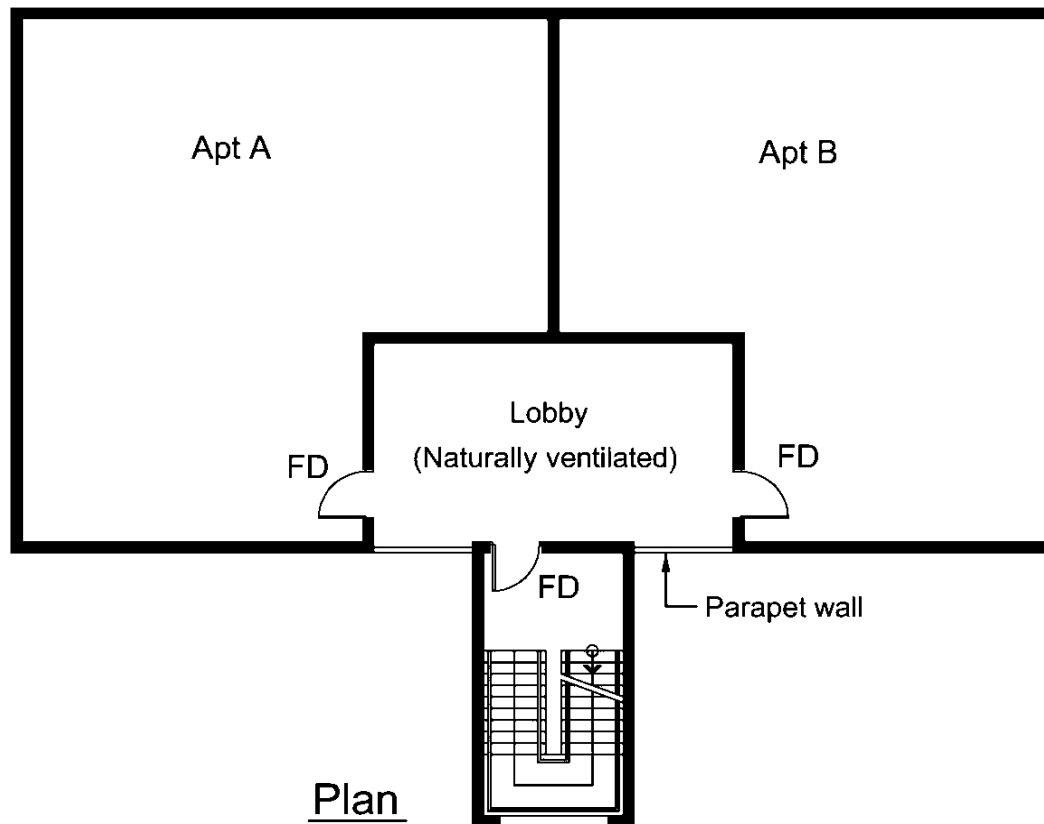

Diagram 2.4.4-2

Single exit staircase is permitted in buildings more than 4 storeys and with habitable height not exceeding 24m, if there is smoke free approach to the exit staircase. This can be achieved by providing a smoke-stop lobby or corridor which is open sided, in compliance with Cl.2.4.8.

EXPLANATIONS & ILLUSTRATIONS

2.4.4

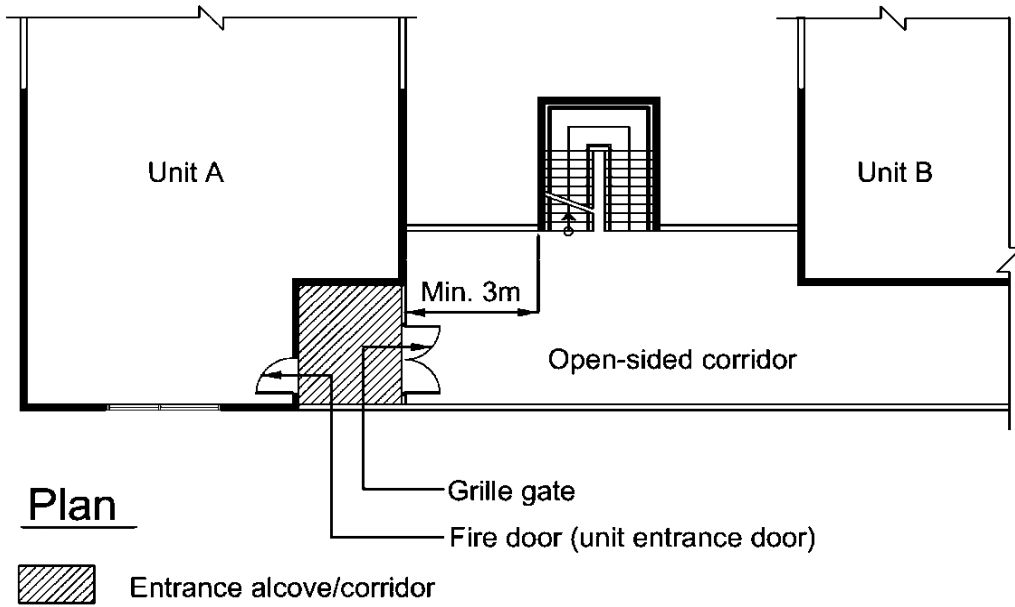

Diagram 2.4.4-3

Single exit staircase is permissible in buildings with 'slab-block' design and with habitable height not exceeding 24m, if there is an open sided corridor between the unit and the exit staircase and where the exit staircase is cross ventilated, provided that the travel distance requirements are complied with.

Not Acceptable

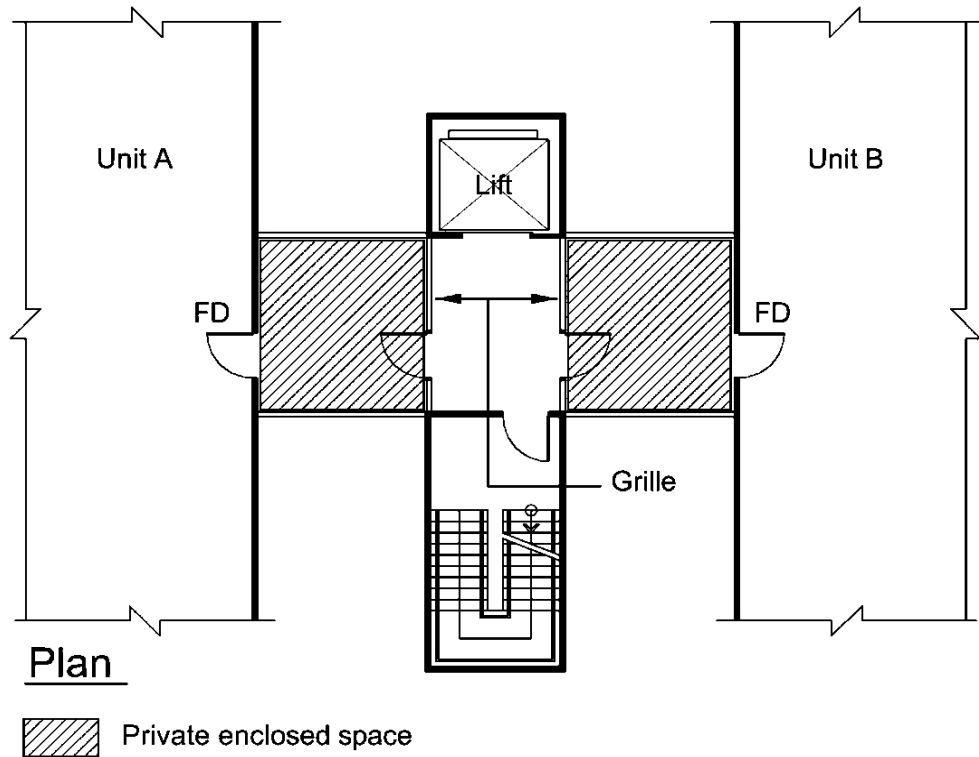

Diagram 2.4.4-4

Ventilation of the lobby through private enclosed space is not acceptable

EXPLANATIONS & ILLUSTRATIONS

2.4.4

Not Acceptable

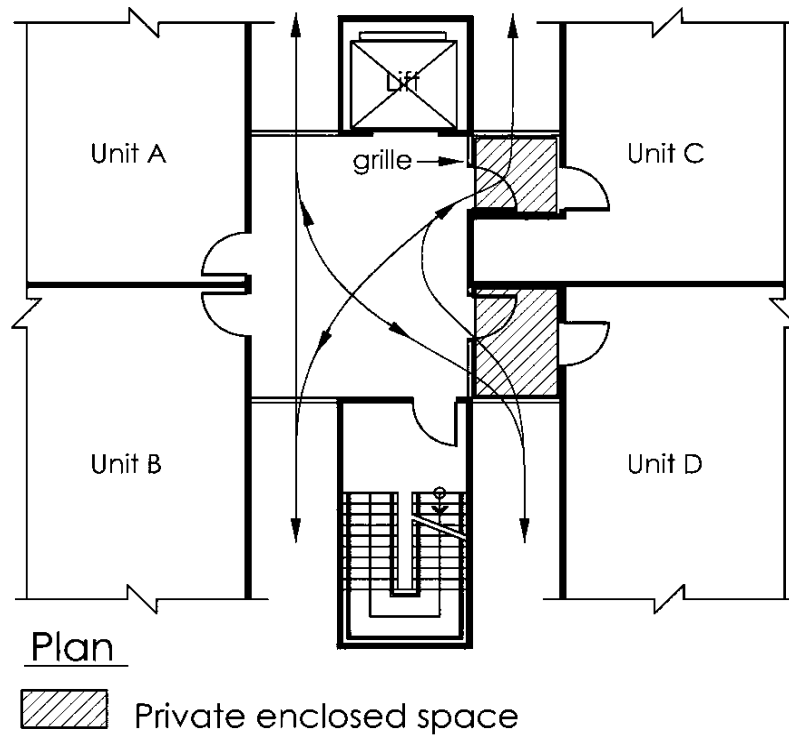

Diagram 2.4.4-5

The provision of ventilation shall not be made via private spaces, as such spaces are subject to modification by the unit owner. In order to ensure the permanency of the means of ventilating the smoke stop lobby, openings for such must always be provided through common areas.

EXPLANATIONS & ILLUSTRATIONS

2.4.4

Protected lobby to single unit storeysPlan

Diagram 2.4.4-6

For single unit per storey design, the smoke-stop lobby or fire-fighting lobby shall not be converted to other usage. It shall be kept free of any article or furniture. Therefore, it shall be kept as a common area and not be included as part of the strata unit. The lobby area acts as buffer zone against smoke migration into the staircase. The fire-fighting lobby is required for use by fire fighters during fire emergency.

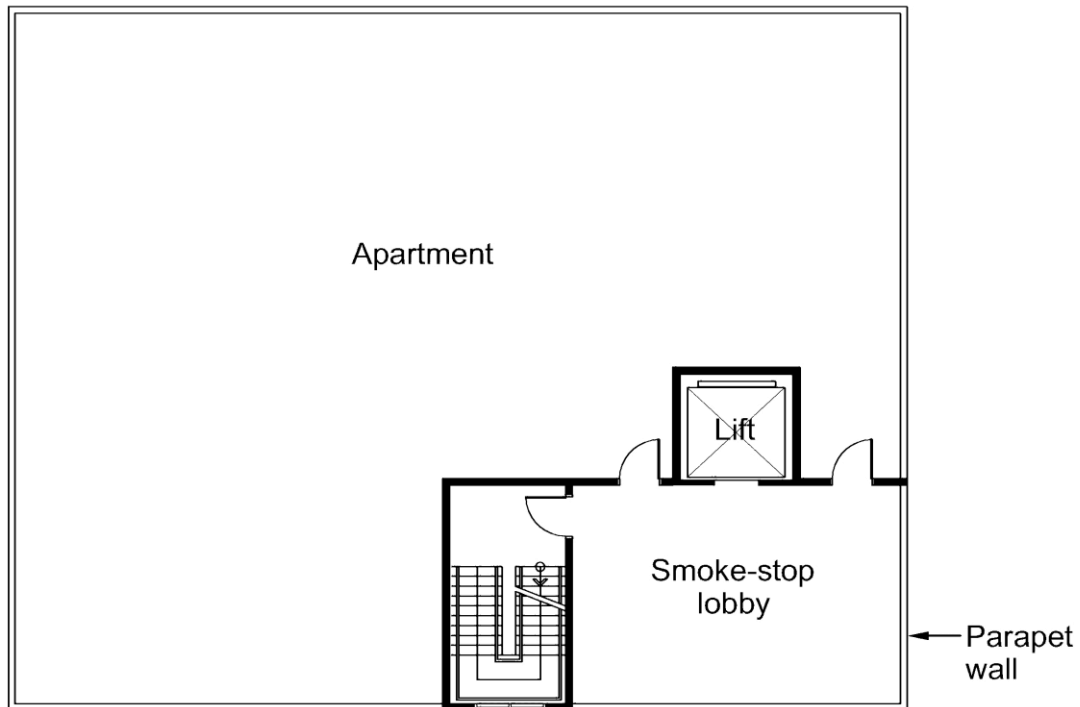

CHAPTER 2

2.4 RESIDENTIAL OCCUPANCY

2.4.5 Provision for buildings exceeding 24m in habitable height

In a block of residential apartments or maisonettes exceeding 24m in habitable height, one exit staircase only may be allowed to serve every upper storey, subject to –

- (a) The height not exceeding 60m unless otherwise permitted by the MFRS, and
- (b) The single exit staircase shall serve not more than four apartments or maisonettes at each storey level, and
- (c) Provision of exits from each residential apartment or maisonette shall comply with the requirements under Cl.2.4.6, and
- (d) Travel distance from the most remote exit door to the exit staircase from each apartment or maisonette shall not exceed 15m, and
- (e) Exit staircase shall comply with the requirements of Cl.2.3.3 for exit staircases, and
- (f) Approach to the exit staircase shall be through cross-ventilated lobby. The ventilation openings having a minimum width of 2000mm and a minimum height of 1200mm shall be unobstructed from parapet wall or balustrade level upwards and be positioned on opposite sides of the lobby such that they provide cross-ventilation throughout the entire space of the lobby. Where multiple ventilation openings are provided on opposite sides of the lobby, the minimum width and height of each opening shall not be less than 1000 mm and 1200mm respectively, provided the aggregate width of the openings at each opposite side is not less than 2000mm. See diagram 2.4.5(f).
- (g) Fire lift shall be provided to comply with the requirements in Chapter 6, and
- (h) Rising main shall be provided to comply with the requirements in Chapter 6, and
- (i) Access to the building for fire-fighting appliances shall be provided to comply with the requirements in Chapter 4.

EXPLANATIONS & ILLUSTRATIONS

2.4.5

Provision of single staircase for residential building not exceeding 60m in habitable height

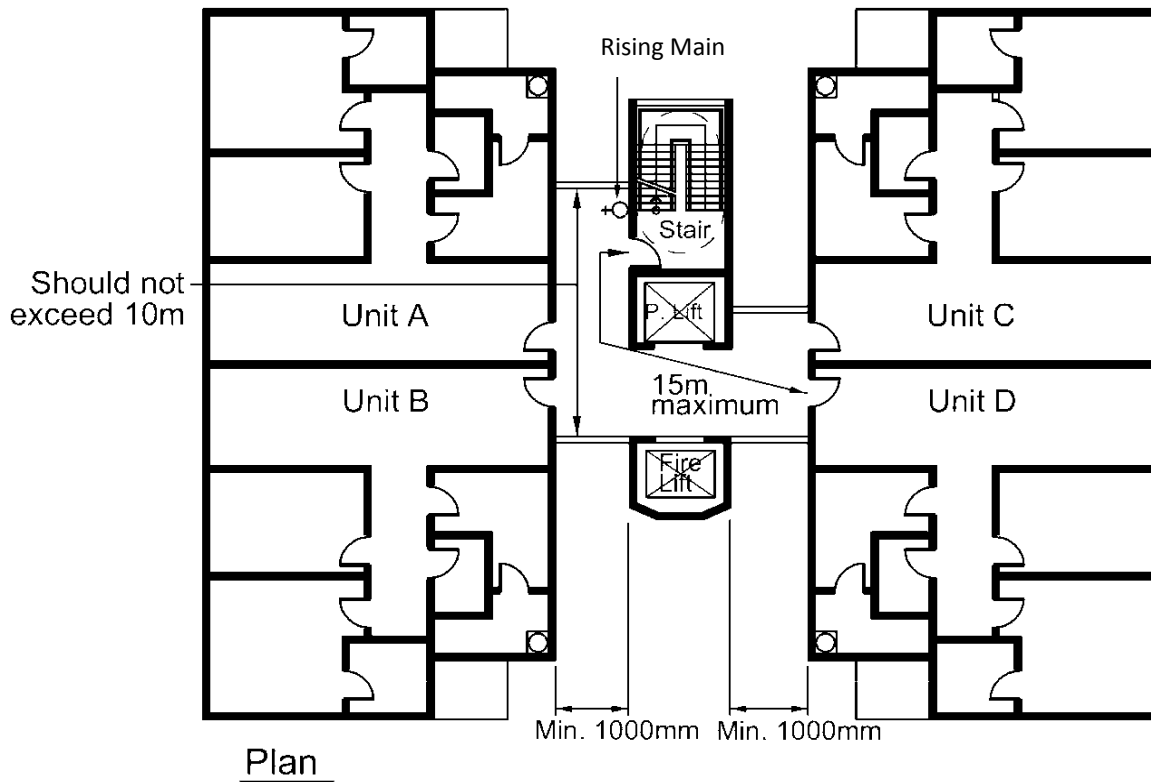

Diagram 2.4.5

Residential buildings not exceeding 60m in habitable height can be provided with single exit staircase, but the approach to exit staircase must be via cross-ventilated lobby. In designing the cross-ventilated lobby, there are instances where building designers only provide the minimum 2m wide and 1.2m high ventilation openings on the opposite ends of the lobby so as to minimize rain water from splashing into the lobby space. There may also be overhang structures at the openings. While the code specifies the minimum opening size for cross-ventilation of the lobby, building designers are encouraged to go beyond this specification. A well-designed cross-ventilated lobby that also addresses rain water from splashing into it can be achieved through thoughtful design at the planning stage. Building designers should also note that the protrusion of any overhang structures at the openings shall not exceed 1.4m. Neither should its design be such that it results in a smaller ventilation openings size e.g. a downward sloping overhang.

EXPLANATIONS & ILLUSTRATIONS

2.4.5

Residential apartment exceeding 24m in habitable height, one exit staircase only may be allowed to serve every upper storey, subjected to:

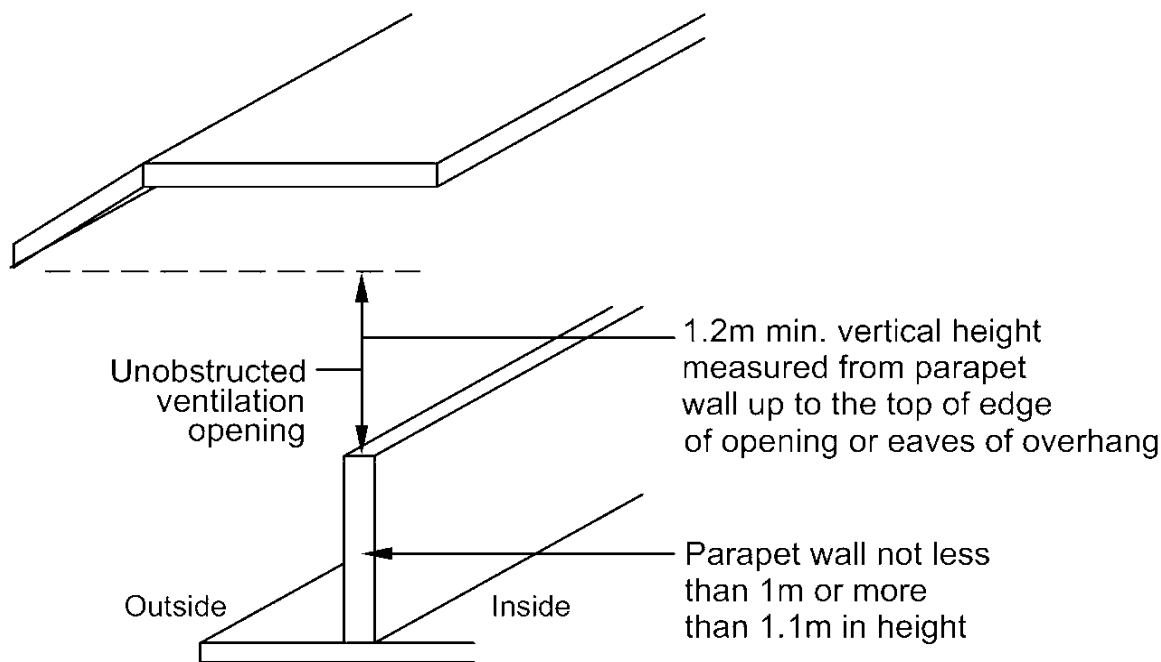

Diagram 2.4.5(f)

Single exit provision – In a block of residential apartments or maisonettes with habitable height not exceeding 60m, one exit staircase only may be provided to every storey.

The provision of single exit staircase must be seen as a relaxation from the two exit staircases requirement. If only one exit staircase is provided, it is important that the smoke free approach to the single exit staircase is absolutely maintained at all times. For this concern, the cross-ventilation openings to the lobby must be maintained and shall not be blocked or obstructed by air -con condensing unit or other structures that may be introduced to keep rainwater away from the lobby.



CHAPTER 2

2.4 RESIDENTIAL OCCUPANCY

2.4.6 Exits from residential unit

Exits from Residential Unit

(a) In each residential apartment or maisonette unit, the exit access door or doors shall be provided such that the travel distances measured from any point within the unit to the entrance door or doors of the unit shall not exceed 20m (see diagram 2.4.6(a)); and

EXPLANATIONS & ILLUSTRATIONS

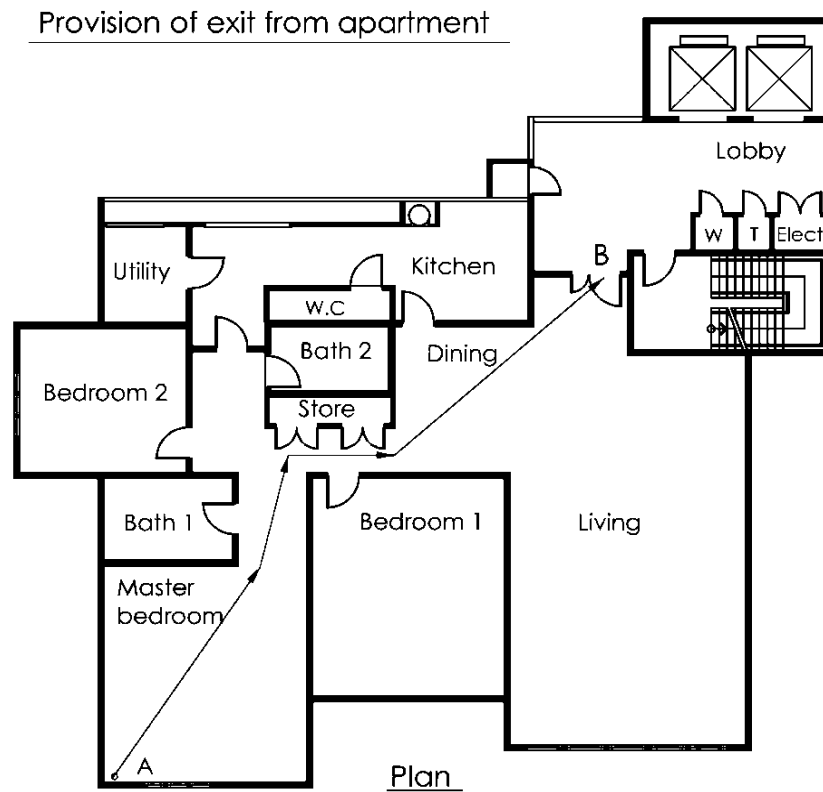
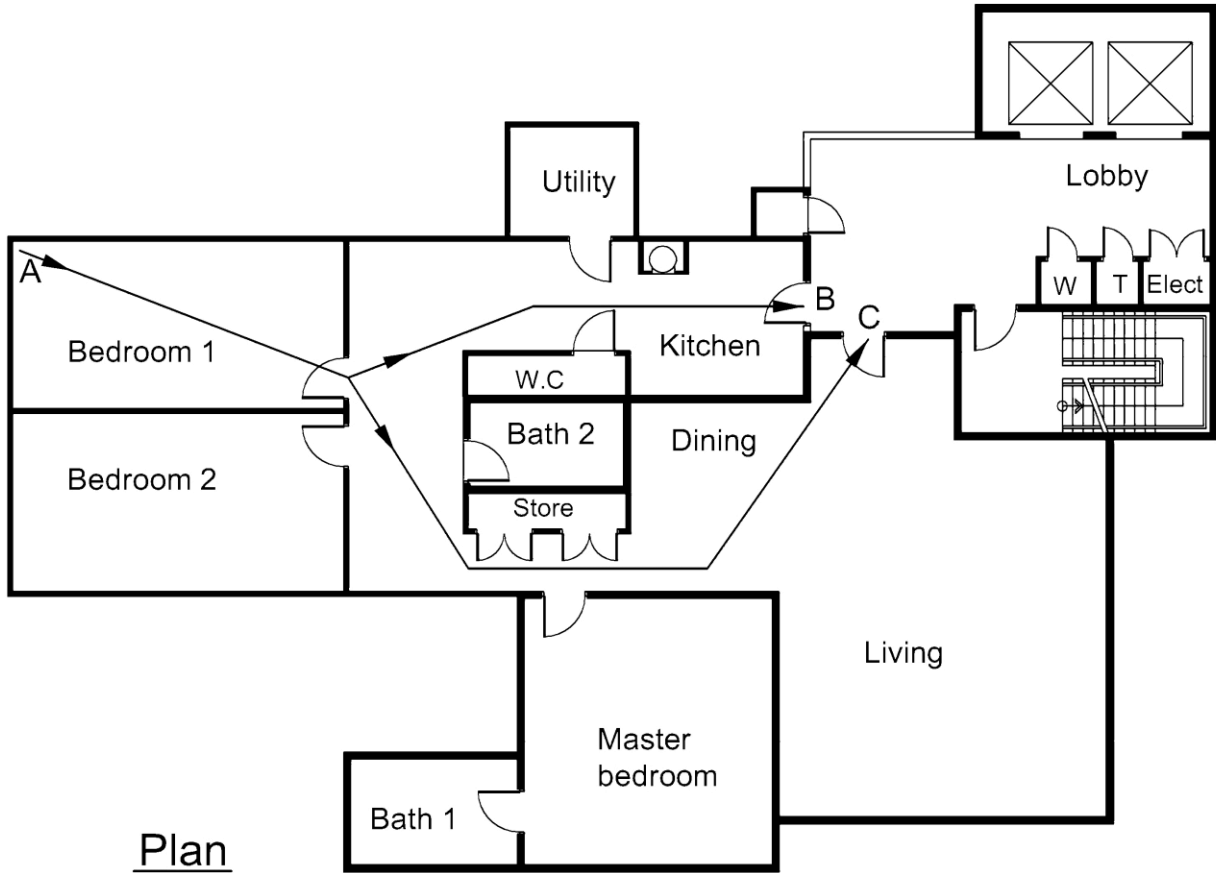

Diagram 2.4.6(a)-1

The travel distances measured from the most remote point (A) in the unit in diagram 2.4.6(a) –1 to its exit door (B) shall not exceed 20m.

EXPLANATIONS & ILLUSTRATIONS

2.4.6



Plan

Diagram 2.4.6(a)-2

If the travel distance from the most remote point (A) in diagram 2.4.6(a) –2 to the unit’s main exit door(C) exceeds 20m, then a second door (B) to the unit is required. The doors shall be located such that the travel distance from any point in that unit to the nearest exit door (B or C) is within 20m. Where a 2nd exit from a unit is required, it shall not pass through utility or storeroom.

- (b) In addition, in the case of a maisonette unit comprising not more than two storeys, where a single door is provided,
 - (i) the door shall not be located on the upper storey of the unit; and
 - (ii) the floor area of the upper storey shall not exceed 60m², unless a separate exit is provided on this upper storey.
- (c) All exits from residential or maisonette units shall have direct access to exit staircase, exit passageway or exterior open space.

EXPLANATIONS & ILLUSTRATIONS

2.4.6

Exit from maisonette unit

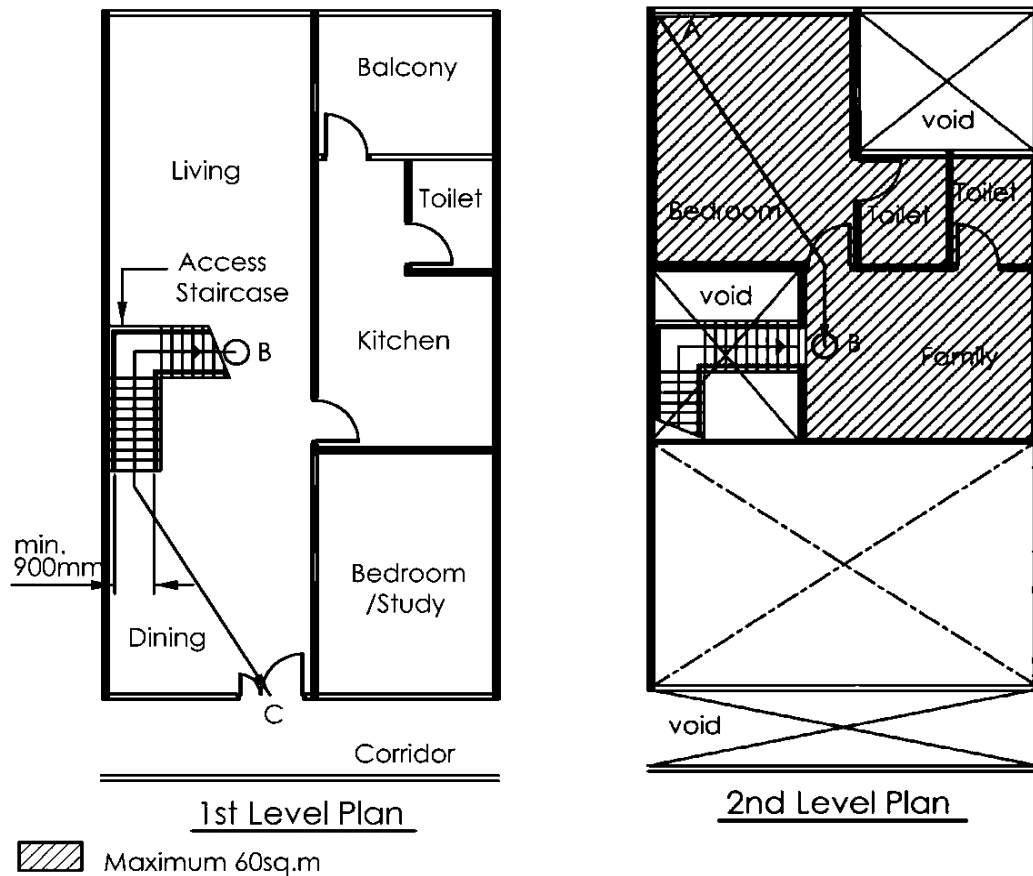

Diagram 2.4.6(b)

The maisonette unit shall not comprise more than 2 storeys and the main exit shall be located at the main storey. If the upper storey exceeds 60m², there shall be at least one exit door from each storey that have direct access to the exit staircase or exit passageways. In the single exit situation, the travel distance (ABC in diagram 2.4.6(b)), measured from the most remote point in the maisonette (point A on the second level), to the main exit door opening to the corridor (point C), shall not exceed 20m.

CHAPTER 2

2.4 RESIDENTIAL OCCUPANCY

2.4.7 Measurement of travel distance

Travel distance shall be measured from the door or doors of the residential apartment or maisonette unit. Where a residential apartment is required to be provided with two doors at the same storey level, and if only one way escape or one exit staircase only is provided, the travel distance shall be measured from the most remote door. If two way escape is achieved, the travel distance shall be measured from each of the doors.

EXPLANATIONS & ILLUSTRATIONS

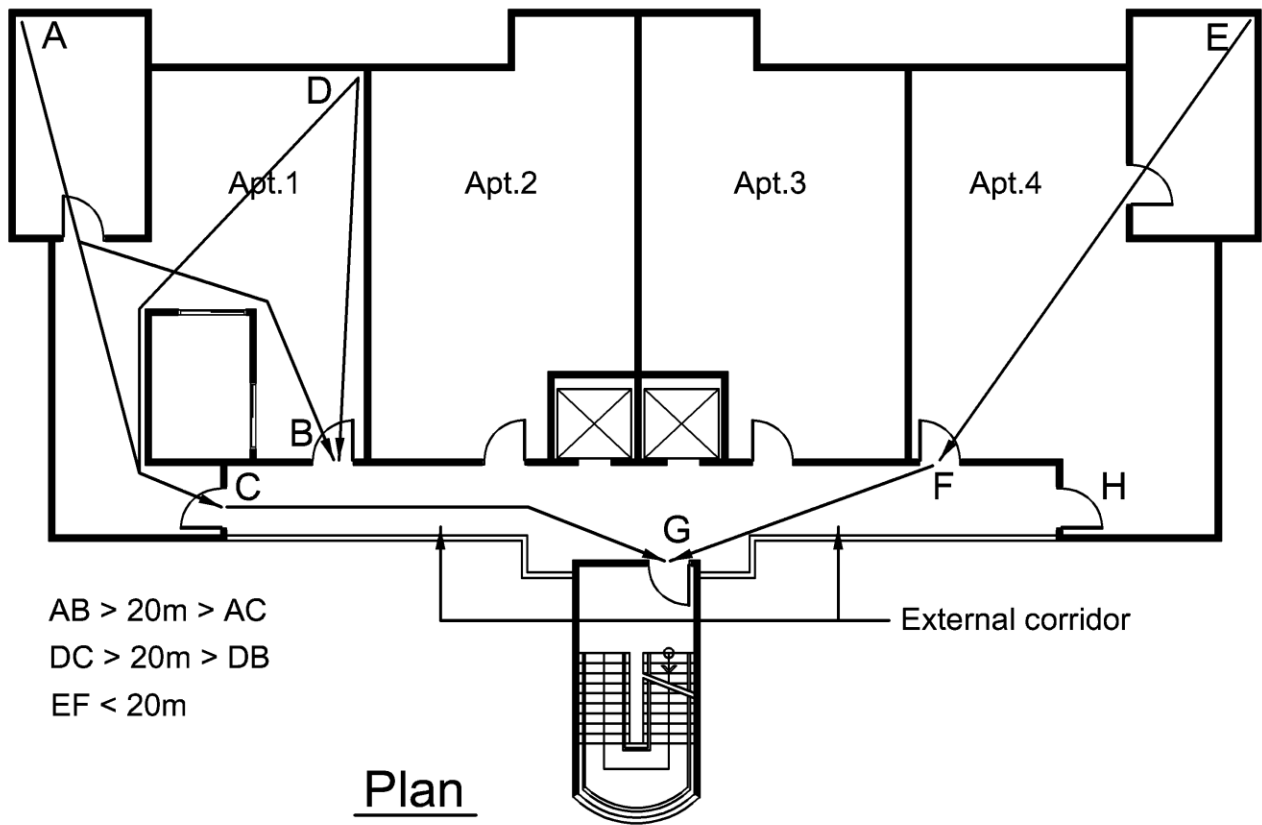

Diagram 2.4.7-1

Doors B and C in diagram 2.4.7 – 1, are the required exits to Apt.1, as both doors are needed to satisfy the internal travel distances from the remote points A and D. Hence, the travel distance from Apt.1 to the exit staircase shall be measured from its most remote door to the exit staircase, which is CG.

In the case of Apt.4, the travel distance to the exit staircase shall be taken from Door H.



EXPLANATIONS & ILLUSTRATIONS

2.4.7

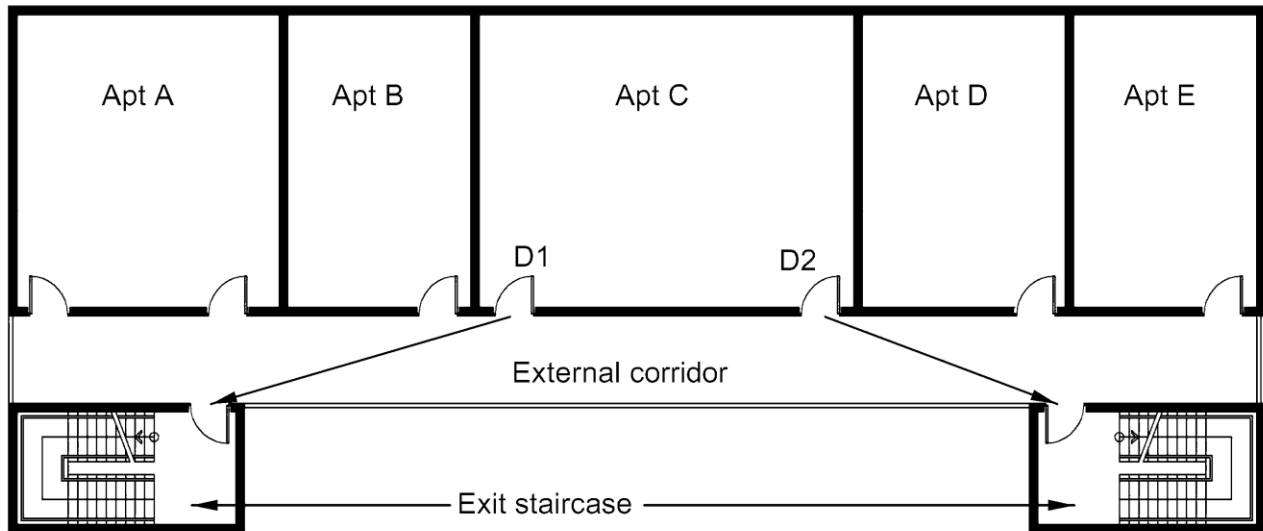

Plan

Diagram 2.4.7-2

Where two way escape is available from an apartment in a residential block with multiple exit staircases, e.g. Apt. C in diagram 2.4.7-2, each of its doors must be within the desired travel distance to their nearest respective exit staircase.



CHAPTER 2

2.4 RESIDENTIAL OCCUPANCY

2.4.8 Smoke-free approach to exit staircase

In a block of residential apartments or maisonettes, smoke free approach to an exit staircase is permitted by means of an external corridor subject to compliance with the following:

- (a) Such external corridors conform to the requirements of external exit passageways for minimum width, headroom clearance, changes in floor level. The provision of parapet wall or balustrade which shall not exceed 1.1m or lower than 1m in height along the outer side of the corridor. The corridor may be roofed over, provided the depth of the roofed over portion shall not exceed 3000mm. The vertical height of the unobstructed ventilation opening measured from the parapet wall or balustrade up to the top edge of the opening or eaves of overhang shall not be less than 1.2m
- (b) The residential apartment or maisonette shall be separated from the external corridor by an external wall with fire resistance rating of at least 1 hour, except that ventilation openings of non-combustible construction may be fixed at or above a level of 1.1 m, measured from the finished floor level of the external corridor to the sill level of the opening.

EXPLANATIONS & ILLUSTRATIONS

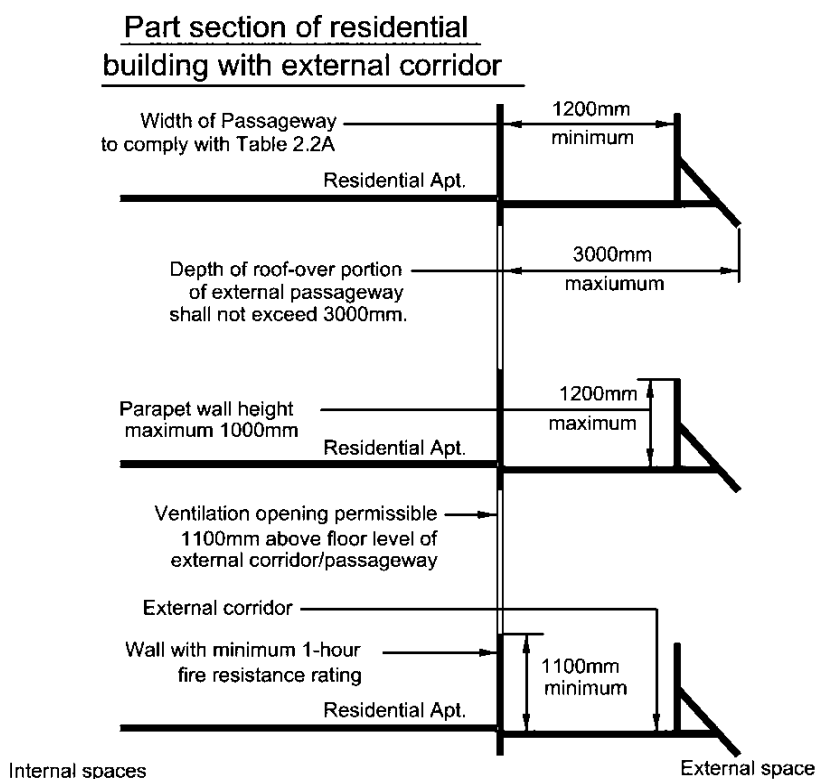

Diagram 2.4.8 (a) & (b)-1



EXPLANATIONS & ILLUSTRATIONS

2.4.8

Typical layout of cross-ventilated internal exit staircase approached from external corridor

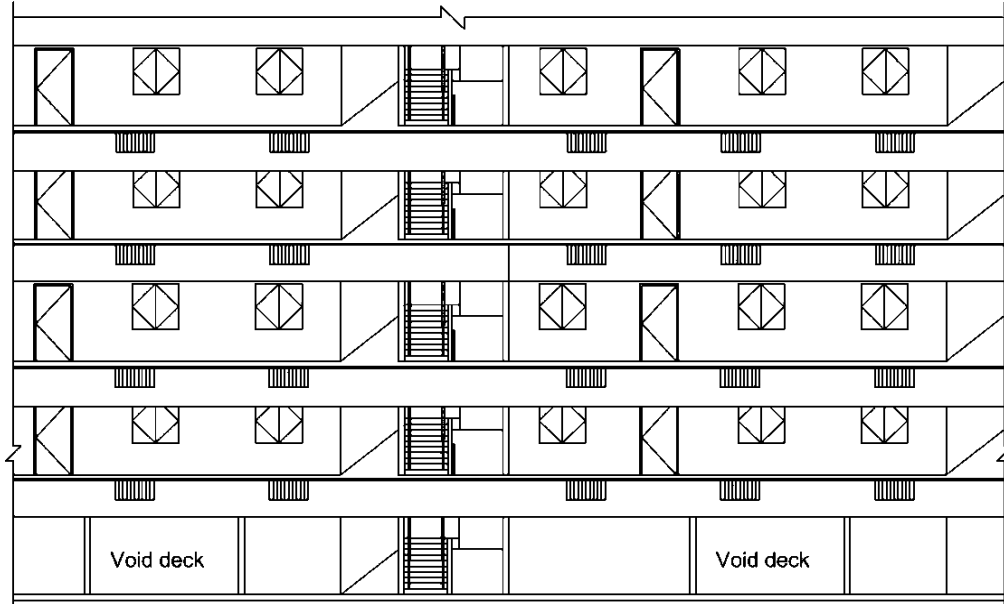

Elevation view

Diagram 2.4.8 (a) & (b)-2

Not Acceptable

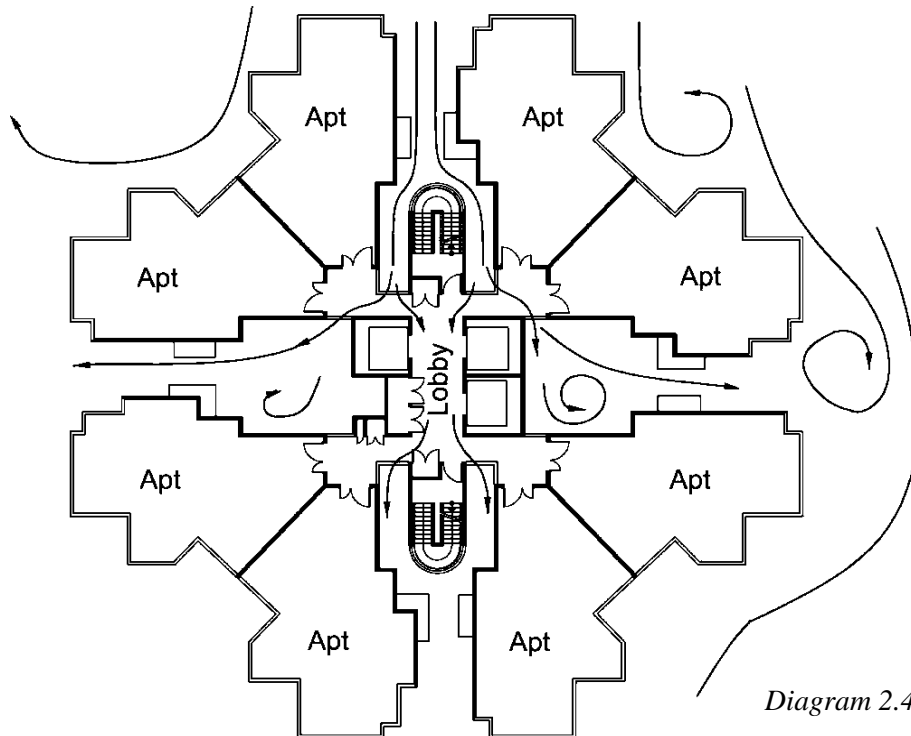

Diagram 2.4.8 (a) & (b)-3

EXPLANATIONS & ILLUSTRATIONS

2.4.8

Acceptable

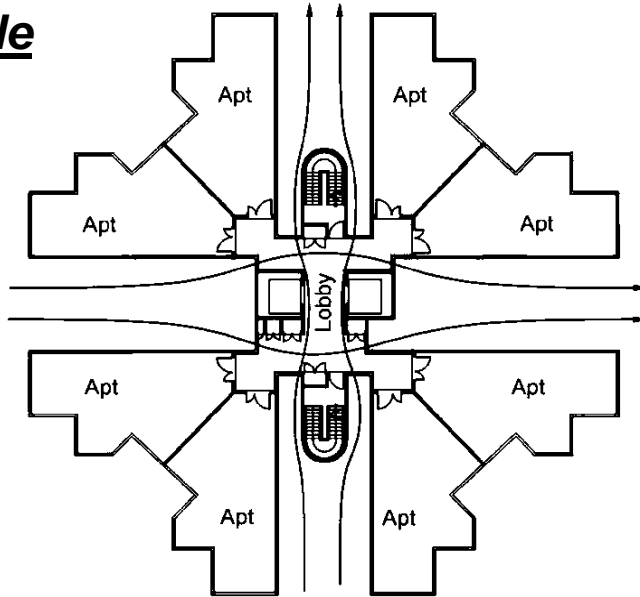

Diagram 2.4.8 (a) & (b)-4

Corridors or lobbies, which are cross ventilated, serve as smoke free approach to exit staircases from residential units. For effective cross ventilation and quick smoke dispersal from these areas, particular attention must be given during design stage of buildings, to ensure clear, wide open unobstructed paths for the passage of the wind currents as shown in diagram 2.4.8(a) & (b) – 4. Layout in diagram 2.4.8(a) & (b) – 3 is not desirable, as the wind path is obstructed, creating a situation whereby smoke build up in the lobby area would be retained for prolonged periods by turbulent eddy wind currents.

Not Acceptable

Ventilation for smoke free approach to exit staircases
Example of a 20th storey apartment building

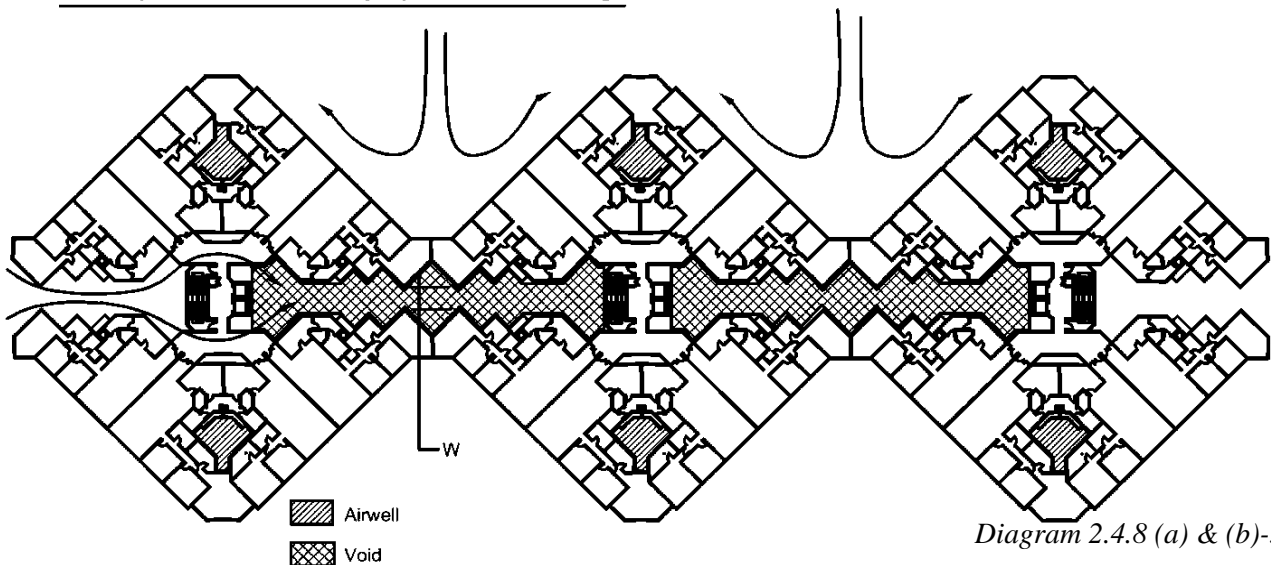
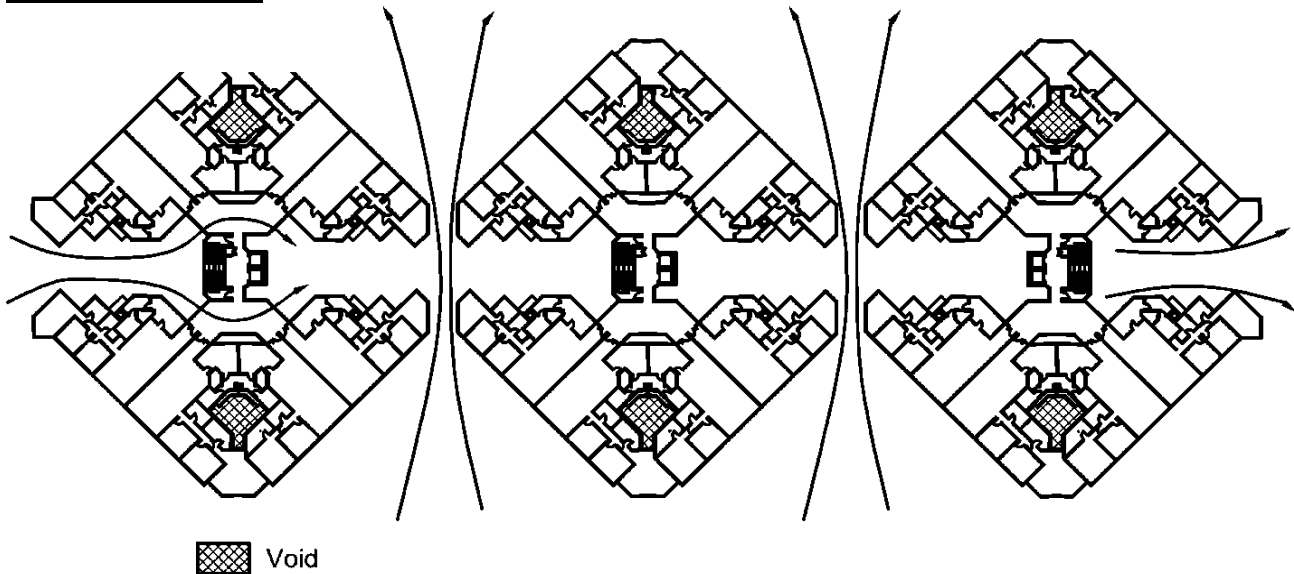

Diagram 2.4.8 (a) & (b)-5

EXPLANATIONS & ILLUSTRATIONS

2.4.8

Acceptable*Diagram 2.4.8 (a) & (b)-6*

The above design layout (diagram 2.4.8 (a) & (b) – 5), is not favourable as ventilation of the corridors and lobbies through the narrow central court or air-well, is not effective for such high-rise development. The staircases are sharing ventilation with other areas via the air-wells. The central services cores, which also incorporates the exit staircases and lifts, further disrupt or obstruct any possible wind current through that air-well space.

For smoke free approach to exit staircases through air-well, open vertically to the sky, the air-well shall have a minimum width (see diagram 2.2.13(a) (iii)-6) of 6m and a superficial plan area of not less than 93 m².

The above layout could be improved by separating the abutting blocks and widening the width of the internal court as shown in diagram 2.4.8(a) & (b)-6,



CHAPTER 2

2.4 RESIDENTIAL OCCUPANCY

2.4.9 Travel Distance

(a) One-way travel distance

In a block of residential apartment or maisonette where the means of escape is through an external corridor, the one-way travel distance measured from the door of the apartment or maisonette to exit staircase shall not exceed 20m or 24m if the aggregate one-way travel distance within the unit and along the external corridor does not exceed 40m. The above one-way travel distances along the external corridor shall not apply to residential apartments or maisonettes in a building exceeding 24m permitted under Cl.2.4.5, and

EXPLANATIONS & ILLUSTRATIONS

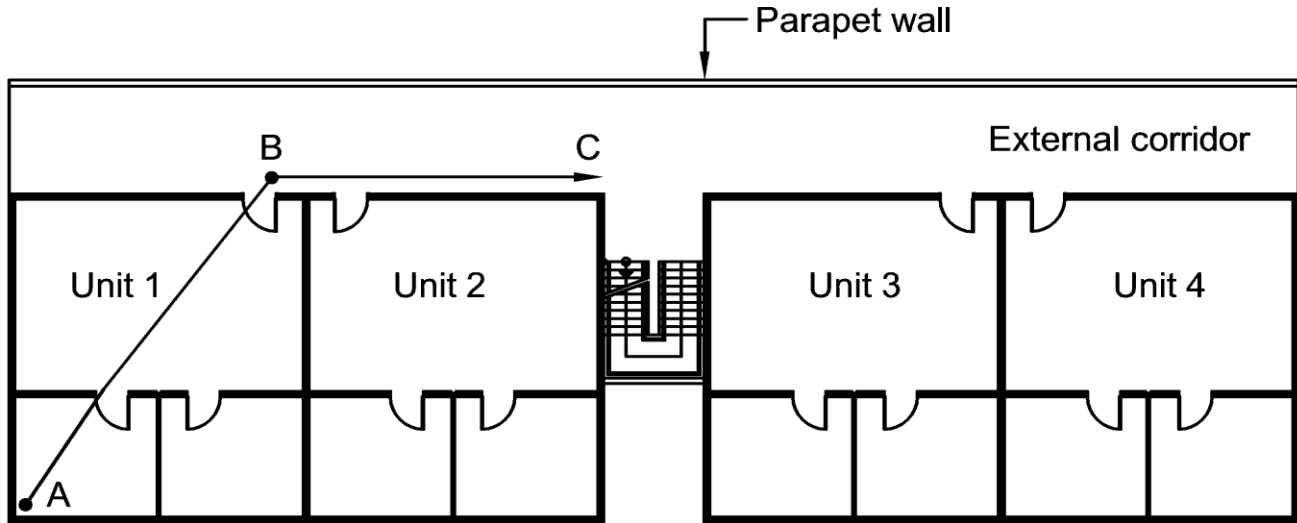

Diagram 2.4.9(a)



(b) Two-way travel distance

In a block of residential apartments or maisonettes, the two-way travel distance may be extended to 45m if the means of escape is through an external corridor as in Cl. 2.4.8.

In the case of buildings which are required to be provided with rising mains, the number and distribution of rising mains specified in Chapter 6 shall be complied with.

EXPLANATIONS & ILLUSTRATIONS

2.4.9

No illustration.

Only in the case of escape via external corridor, the travel distance can be extended to 45m.

CHAPTER 2

2.4 RESIDENTIAL OCCUPANCY

2.4.10 Protection of staircases

The provisions of Cl.2.3.3 (a) (ii) and (b) (ii) that there shall be no unprotected openings within 3m horizontally or vertically below ventilation openings of exit staircases may not be applicable in the case of exit staircases for residential apartments or maisonettes provided:

- (a) the exit staircases are cross-ventilated and maintained under smoke free condition at all times; and
- (b) unprotected openings of the apartment or maisonette units are not facing or ventilating into the exit staircase enclosures as shown in diagram 2.4.10.

EXPLANATIONS & ILLUSTRATIONS

Exemption from 3m clearance of
unprotected openings from exit staircase

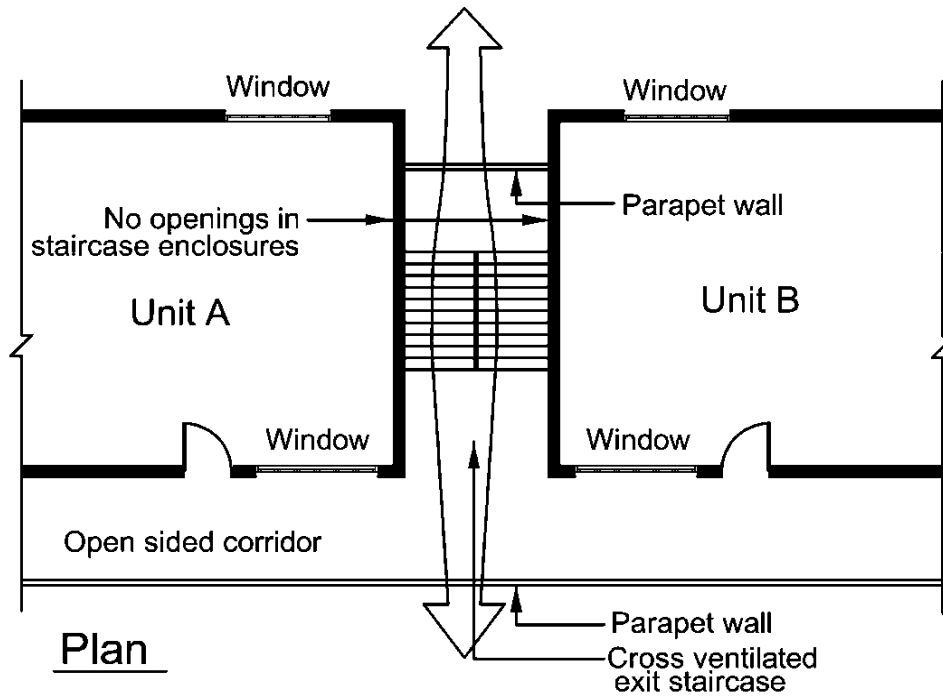

Diagram 2.4.10

Cross-ventilated exit staircase of residential apartments or maisonettes, shown in above, should be able to prevent any accumulation of smoke and provide the smoke free condition for occupants to evacuate. The above clause grants a relaxation of the requirement for 3m separation of unprotected openings from exit staircases, required under Cl.2.3.3, and is only applicable to residential buildings.



CHAPTER 2

2.4 RESIDENTIAL OCCUPANCY

2.4.11 Residential doors opening into external corridors

Doors of residential apartments or maisonettes opening into external corridors need not have fire resistance rating.

EXPLANATIONS & ILLUSTRATIONS

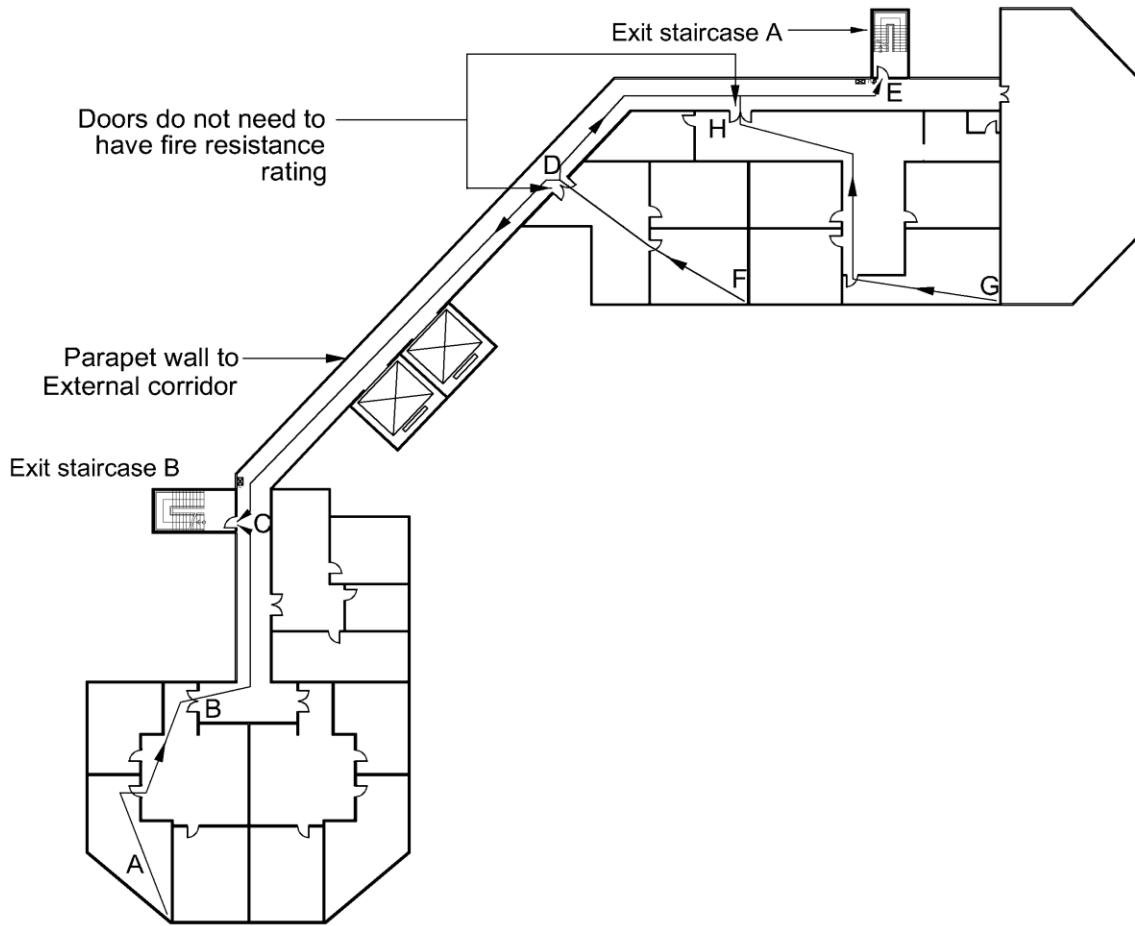

Diagram 2.4.11

As external corridors, mentioned in clauses 2.2.13 and 2.4.8, would be able to provide good venting for smoke and heat, doors of apartment or maisonette units opening into such external corridors, as shown in diagram 2.4.11, need not have fire resistance rating.



CHAPTER 2

2.4 RESIDENTIAL OCCUPANCY

2.4.12 Attic floor

An attic in buildings under Purpose Group I and II can be constructed of timber boardings on timber joists, provided it is protected to achieve the fire resistance rating required of the elements of structure of the building or compartment.

EXPLANATIONS & ILLUSTRATIONS

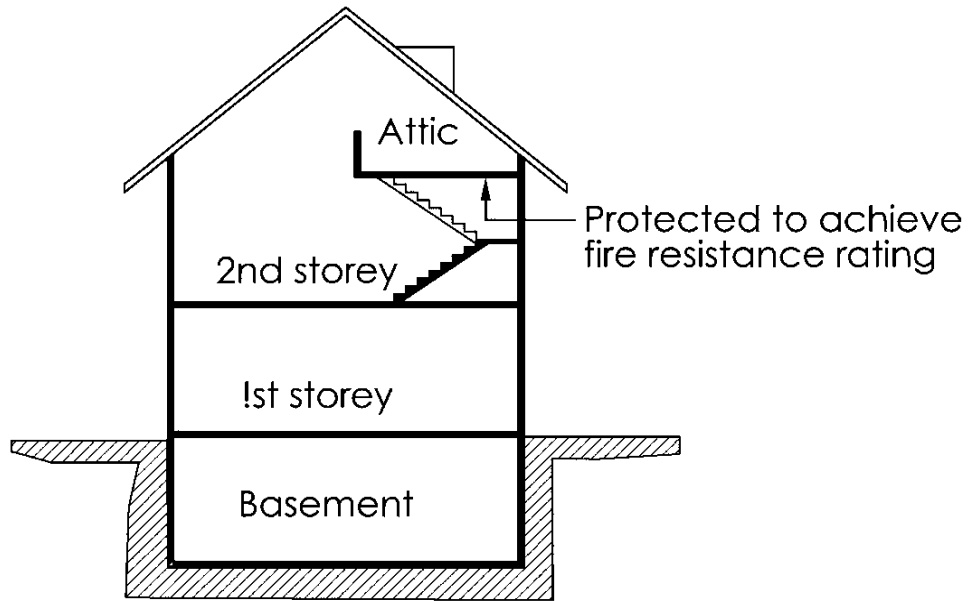

Diagram 2.4.12

- a. An attic can be added to new or existing buildings under purpose group I, provided the total number of storeys or levels in the building does not exceed 4, inclusive of basement.
- b. The attic can be constructed of timber boardings on timber joists, provided that it is protected to achieve the fire resistance rating required of the elements of structure of the building (see diagram 3.3.6).



EXPLANATIONS & ILLUSTRATIONS

2.4.12

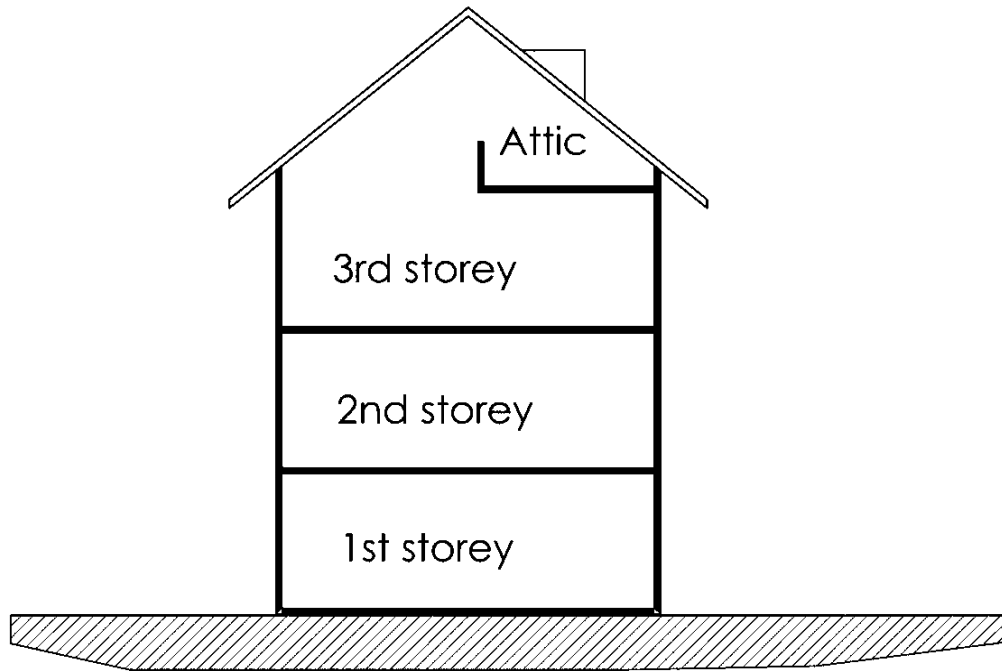

Diagram 2.4.12

The above should be seen as a relaxation as timber floors are only allowed in buildings under conservation. Owing to the need to create additional living space in existing houses for extended family use, etc many applications were received to have addition of attic. In all the applications affecting existing buildings, timber floor construction was the norm for ease of construction and the need to consider the dead load affecting the existing structures..



CHAPTER 2

2.4 RESIDENTIAL OCCUPANCY

2.4.13 Common corridor – means of ventilation

The common internal corridor not forming part of smoke free approach to exit staircase shall have ventilation openings of not less than 15 per cent of the floor area and located not more than 9m from any part of the common internal corridor. If the common internal corridor is cross-ventilated, the fixed ventilation openings at each end of the wall shall not be less than 50 per cent of the superficial area of the end walls. No part of the floor area of the common internal corridor shall be at a distance of more than 13m from any ventilation openings.

EXPLANATIONS & ILLUSTRATIONS

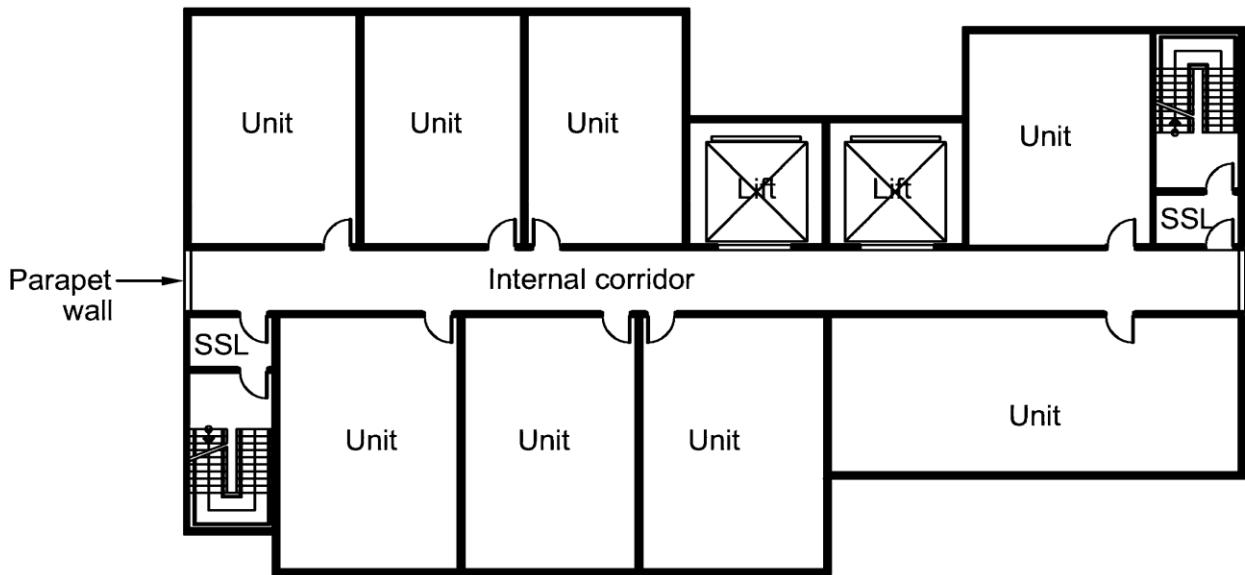

Diagram 2.4.13

To address smoke logged situation that may take place in an internal corridor, a suitable means of ventilation shall be provided. In a case of long internal corridor with units entrance fronting, it shall be provided with cross ventilation. Each end of the wall shall not be less than 50% of the superficial area of the end walls.



CHAPTER 2

2.5 HEALTH CARE OCCUPANCY

2.5.1 General

The provisions stated herein shall apply to Health Care Occupancies which may be identified under the following categories:

(a) Hospital

A building used for medical and surgical care and shall include general hospitals, hospitals for psychiatric care, children's hospitals, with 24 hours or in-patient service.

(i) Basement

Patient accommodation area containing beds shall not be located in the basement storey.

(ii) Number of exits per ward

Each patient accommodation ward area shall be provided with at least 2 exits, which shall be remotely located from each other, if the occupant load exceeds 50 persons.

(iii) Provision of area of refuge

Every upper storey used for the accommodation of patients shall be provided with at least an area of refuge for horizontal evacuation purposes. The size of the area of refuge and the routes leading to it shall comply with clauses 1.2.4 and 2.5.3.

(iv) Size and compartmentation of patient accommodation area

(1) Each patient accommodation ward shall not exceed a floor area of 750m² and an occupant load of 75 persons, calculated on the basis of gross floor area of 10m² per person.

(2) Each patient accommodation ward area shall be constructed as a compartment having fire resistance rating of at least 1-hour for walls/ceilings and ½-hour fire door for protection of door openings. The internal walls between wards shall be constructed to have min. 1-hour fire resistance rating and door opening shall be protected by ½ hour fire door. For walls and doors between ward and main exit access corridor (either internal or external corridor), the requirements given in sub clause 2.5.1(a)(vi) and 2.5.1(a)(vii) respectively shall be complied with. This requirement shall not be applicable to patient accommodation floor which is sprinkler protected.



EXPLANATIONS & ILLUSTRATIONS

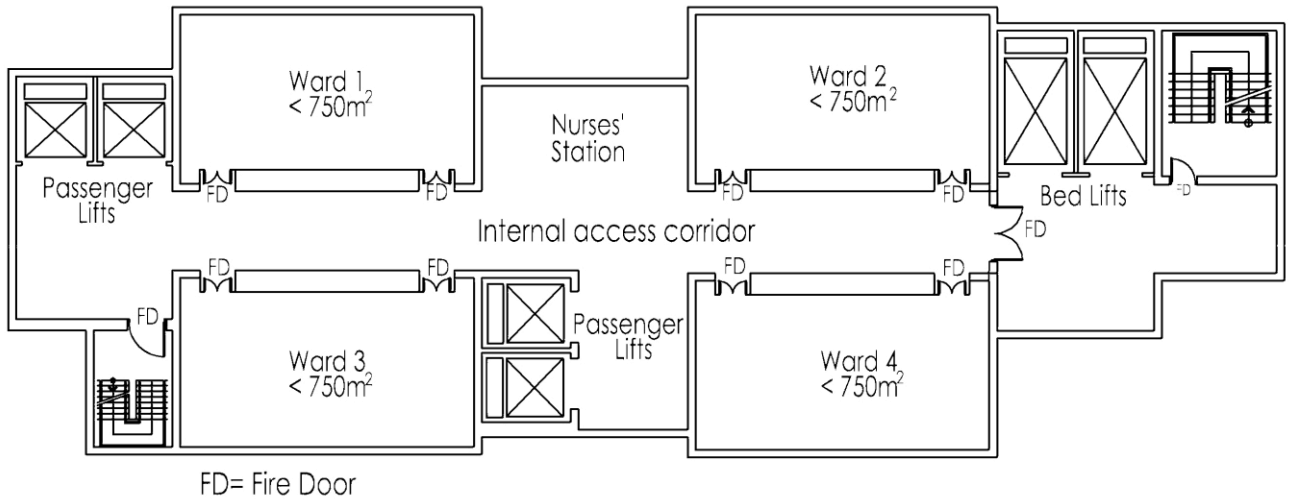

Diagram 2.5.1 (a) (iv)

The above diagram shows 4 wards that are fire compartmented from the internal corridor by walls and doors having 1-hour and ½ hour fire resistance rating respectively.

(a)(v) Provision of Escape Bed-lifts

- (1) An escape bed-lift shall be provided adjacent to a protected exit staircase to serve every storey and/or every area of refuge above the 1st storey containing Operating Theatre Department, Coronary Care Unit, Intensive Care Units, Intensive Therapy Units, Neo Natal Units and patient accommodation areas where patients could not be able to be evacuated, in the event of a fire, by any means other than a bed, patient trolley or similar conveyance.
- (2) A protected shaft containing an escape bed-lift shall be constructed to comply with the relevant requirements under clause 3.8.
- (3) The entry into the escape bed-lift and the protected exit staircase shall be through a common protected lobby. The protected lobby shall have a floor area of not less than 9 m², having a depth of min. 2.5m perpendicular to the lift landing door, and shall be large enough to hold a minimum of two beds, attendant staff and additional equipment. In the situation where the protected lobby is also acting as a smoke-stop lobby or fire-fighting lobby, the floor area of the lobby shall be of sufficient size to allow the evacuation of the required number of beds and the movements of other occupants into the protected staircase.
- (4) Escape bed-lift is to be used for the evacuation of patients in beds including those confined to wheel-chairs or physically disabled, in a fire emergency, although it can be used as a normal passenger lift during normal times in the day to day running of the hospital. A signage shall be posted outside the bed-lift stating “FIRE ESCAPE BED-LIFT”

EXPLANATIONS & ILLUSTRATIONS

2.5.1

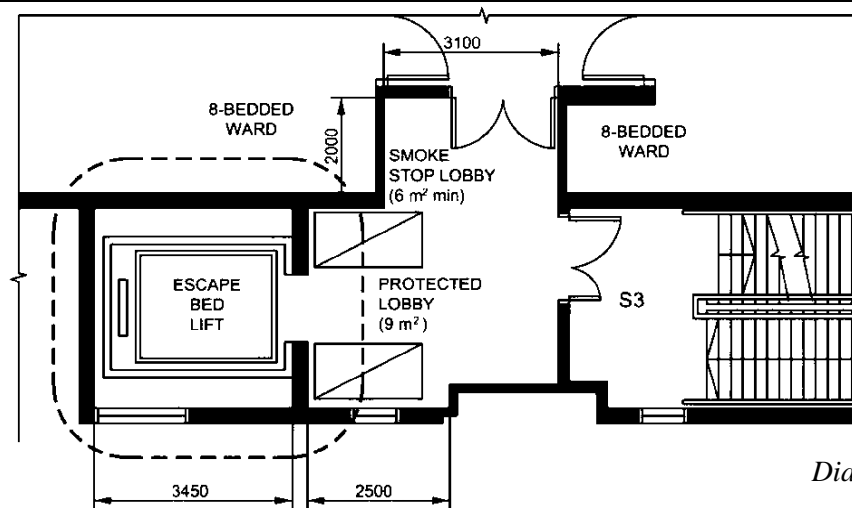

Diagram 2.5.1(a)(v)(3)

Escape bed lifts are used for the evacuation of patients who are bed-ridden. The escape bed lift shall be provided adjacent to a protected exit staircase. The protected shaft to the bed lift shall comply with clause 3.8. The protected lobby serving the bed-lift shall have a floor area of not less than 9m² and a depth of min 2.5m perpendicular to the lift landing door. A signage shall be posted outside the bed lift, stating “Fire Escape Bed-Lift”.

- (5) The escape route for the escape bed-lift at the 1st storey level shall be made protected from other occupancy areas by minimum 1-hour fire resistance separation and shall discharge directly into a safe exterior space.

EXPLANATIONS & ILLUSTRATIONS

2.5.1(a)(v)

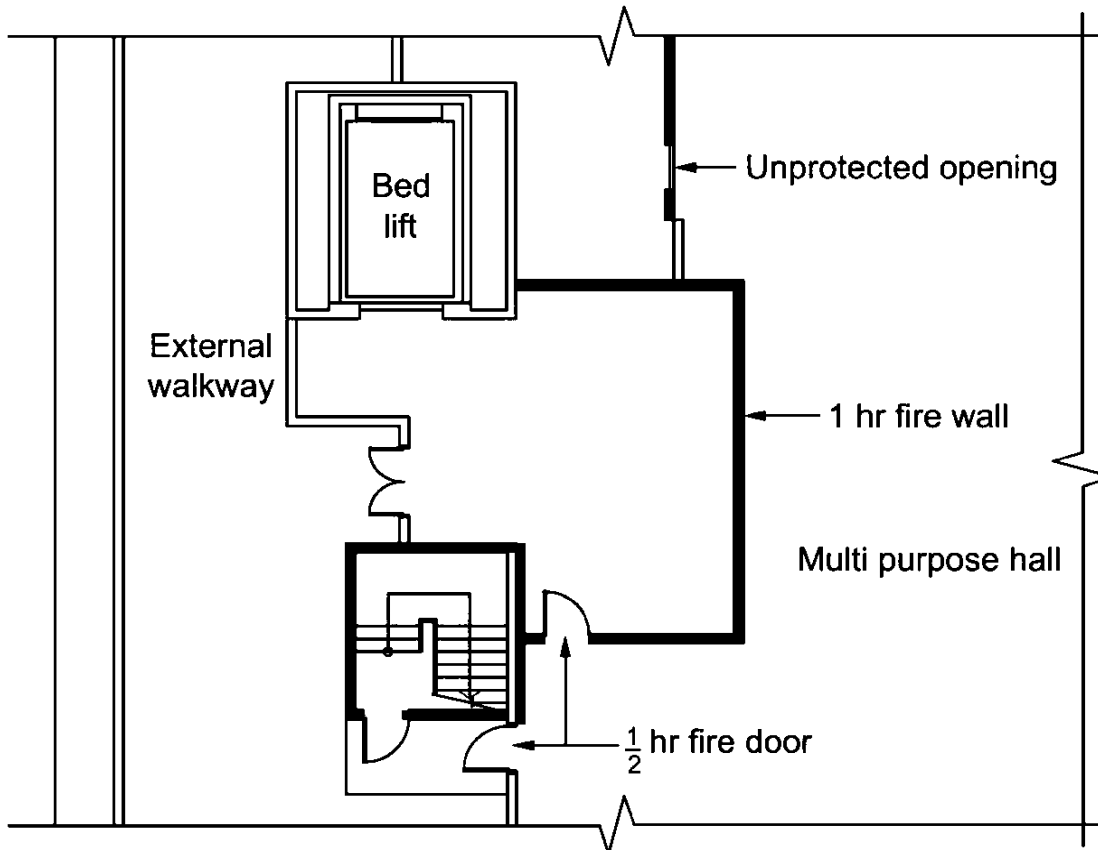

Diagram 2.5.1(a)(v)(5)

The discharge route for the exit bed lift is to be protected from other occupancy by 1-hour fire rated wall and 1/2 hour fire door



(6) An escape bed-lift that opens directly into an external corridor and is sited adjacent to a protected exit staircase does not require a protected lobby, provided there is no unprotected opening within 3m horizontally from the escape bed-lift door opening. The escape bed-lift provided under the above situation may be treated as common bed-lift that can serve multiple compartments located on the same floor.

EXPLANATIONS & ILLUSTRATIONS

2.5.1(a)(v)

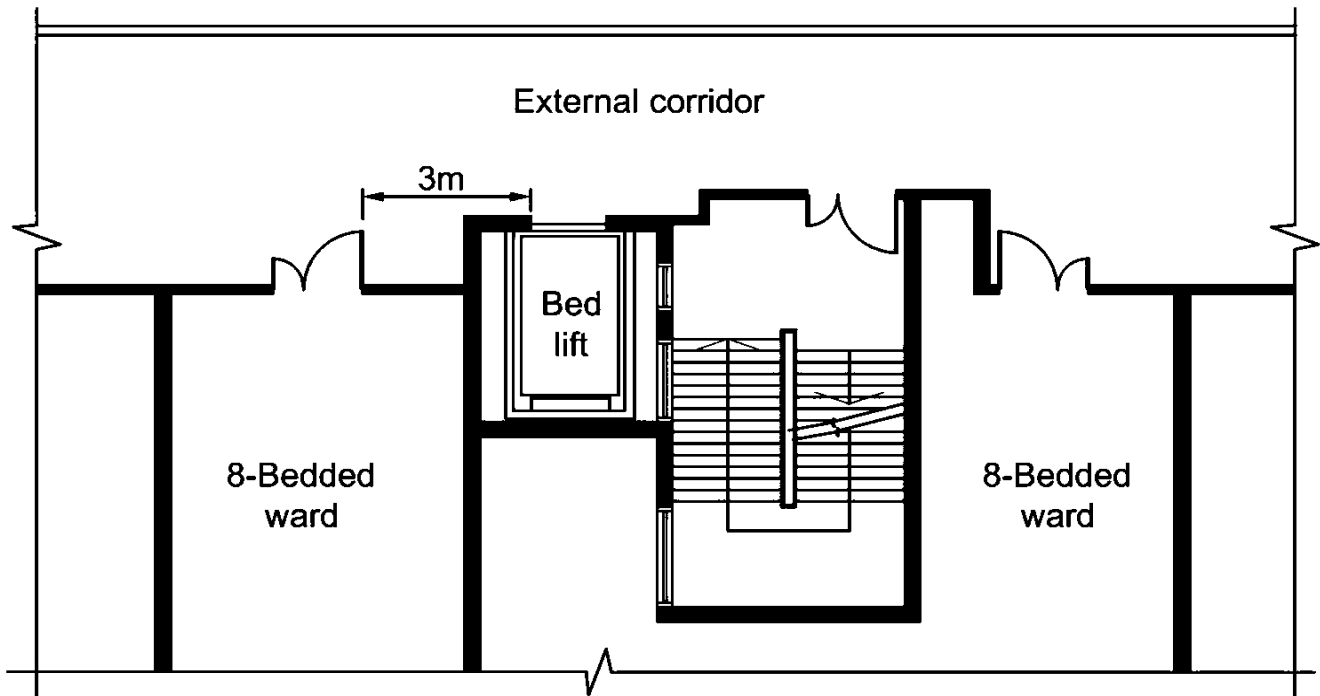

Diagram 2.5.1(a)(v)(6)

The provision of protected lobby to the bed lift is not required, provided there is no unprotected opening within 3m horizontally from the bed-lift door opening.



(7) An escape bed-lift shall be provided with the following features :

- a duplicate power supply from an emergency generating plant;
- a switch labelled “Evacuation Bed-Lift” situated next to the lift landing door at the final exit storey, which enables an authorised person nominated by the building management to take control of the lift car during an emergency. Operation of the switch should isolate the lift landing call controls and return the lift immediately to the final exit storey, where upon the lift can only operate in response to the lift car control panel. Such a switch is not needed in 2-storey buildings; and
- a communications system (except in 2-storey building) should be installed to allow communication between occupants at each lift landing and the operator in the lift car.

(8) The installation of escape bed-lifts shall be in accordance with BS EN 81-20.

EXPLANATIONS & ILLUSTRATIONS

2.5.1(a)(v)

No illustration.

To ensure that the escape bed lift will stay operational during a fire emergency or a power failure in the building, a duplicate power supply from an emergency plant, such as a generator set, shall be provided.



2.5.1(a)(vi) Internal access corridor to wards

Patient accommodation ward with access through an internal access corridor shall comply with the requirements as follows:

- (1) Each ward shall be separated from the internal access corridor by a wall having fire resistance of at least 1-hour; and
- (2) Doors opening into internal access corridor shall have fire resistance of at least ½-hour and fitted with automatic self-closing device to comply with the requirements of cl.3.9.2; or held open by electromagnetic or electromechanical device; and

EXPLANATIONS & ILLUSTRATIONS

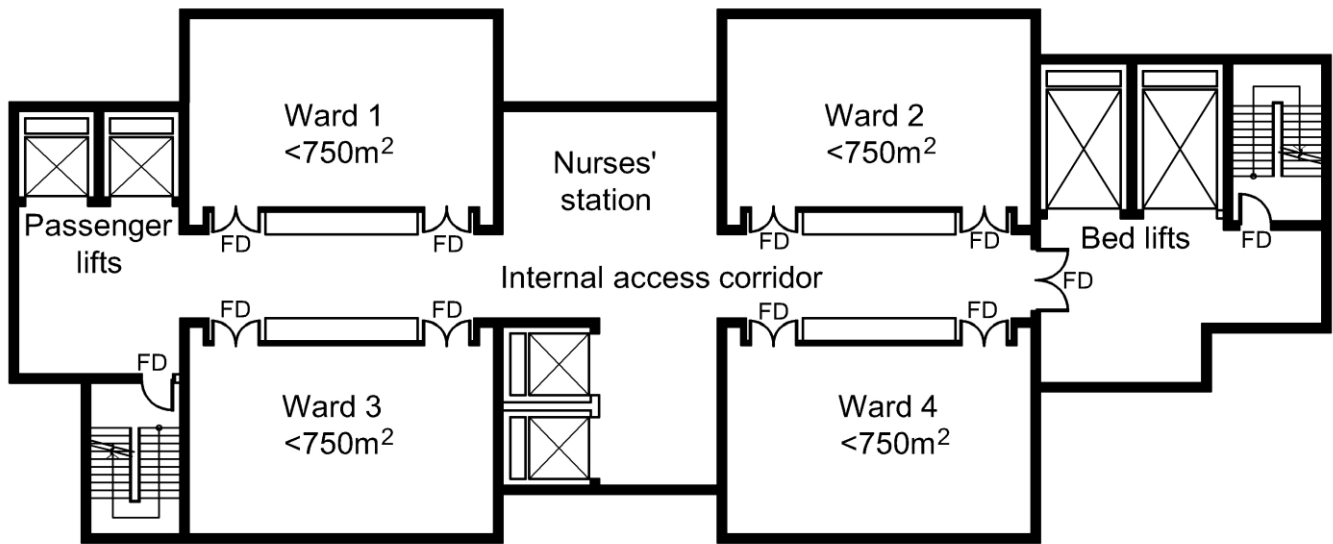

FD = Fire door

Diagram 2.5.1(a)(vi)

As the internal access corridor is an escape route for all the occupants in Wards 1 to 4, it shall be made protected from the ward areas.



- (3) Requirements on fire compartmentation under (vi)(a) and (vi)(b) will not be applicable if the patient accommodation floor is sprinkler protected; and
- (4) Internal access corridors shall be naturally ventilated with fixed openings in an external wall, such ventilation openings being not less than 15 percent of the floor area of the internal access corridor; and
- (5) The ventilation opening in the external walls shall not be less than 3.5m² and shall be unobstructed from parapet wall or balustrade level upwards and be positioned on opposite sides of the internal access corridor such that they provide effective cross-ventilation throughout the entire space of the corridor; and
- (6) The ventilation openings in the external walls shall not be more than 12m from any part of the internal access corridor; and
- (7) Internal access corridor may be provided with mechanical ventilation and pressurisation in lieu of natural ventilation; and
- (8) Other non-patient accommodation areas or spaces which open into or form part of the internal access corridor and which may prejudice the means of escape provision shall be compartmentalised by min. 1-hour fire rated enclosures and min ½-hour fire doors.

EXPLANATIONS & ILLUSTRATIONS

2.5.1(a)(vi)

No illustration.



2.5.1(a)(vii) External access corridor

Patient accommodation ward with access through an external access corridor shall comply with the requirements as follows:

- (1) Patient accommodation ward shall be separated from the external access corridor by a wall having fire resistance of at least 1-hour, except that ventilation openings of non-combustible construction may be fixed at or above 1.1m, measured from the finished floor level of the external exit access corridor to the sill height of the opening; and
- (2) Doors opening into the external access corridor shall not be required to have fire resistance rating; and
- (3) External access corridor shall conform to the requirements of external exit passageway for minimum width, changes in floor level, roof protection and provision of parapet wall or solid balustrade which shall not exceed 1000mm height along the outer side of the corridor.

EXPLANATIONS & ILLUSTRATIONS

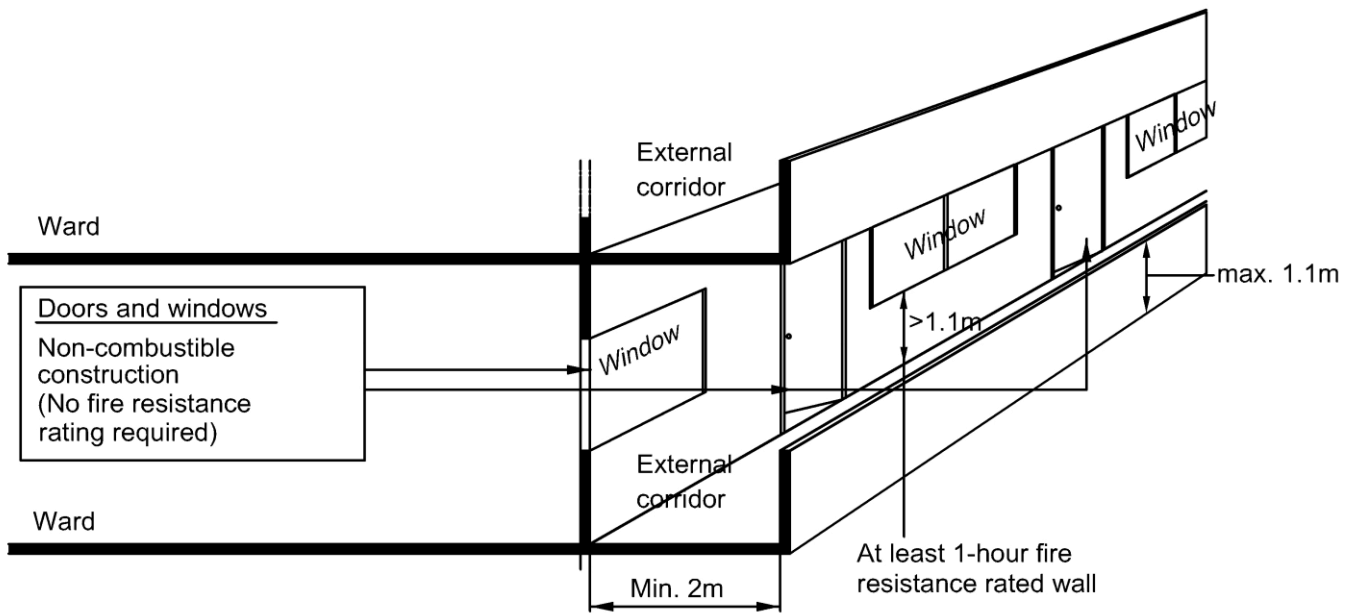

Diagram 2.5.1 (a)(vii)

2.5.1(a)(viii) Smoke free approach to exit staircase

- (1) Entry into an exit staircase from any part of a building of more than 4 storey above ground level shall comply with cl.2.2.13 – requirements of smoke free approach to an exit staircase. Pressurisation of staircase in lieu of the provision of smoke-stop lobby is not permitted.
- (2) Any exit staircase which serves a basement storey shall comply with Cl.2.2.14 and Cl.2.3.5.
- (3) Where a smoke-stop lobby is provided to exit staircase to serve a patient accommodation floor, or any area where patients may need to be evacuated on mattresses or stretchers, the lobby shall have a minimum clear space (unobstructed by door swings) of 6m².

EXPLANATIONS & ILLUSTRATIONS

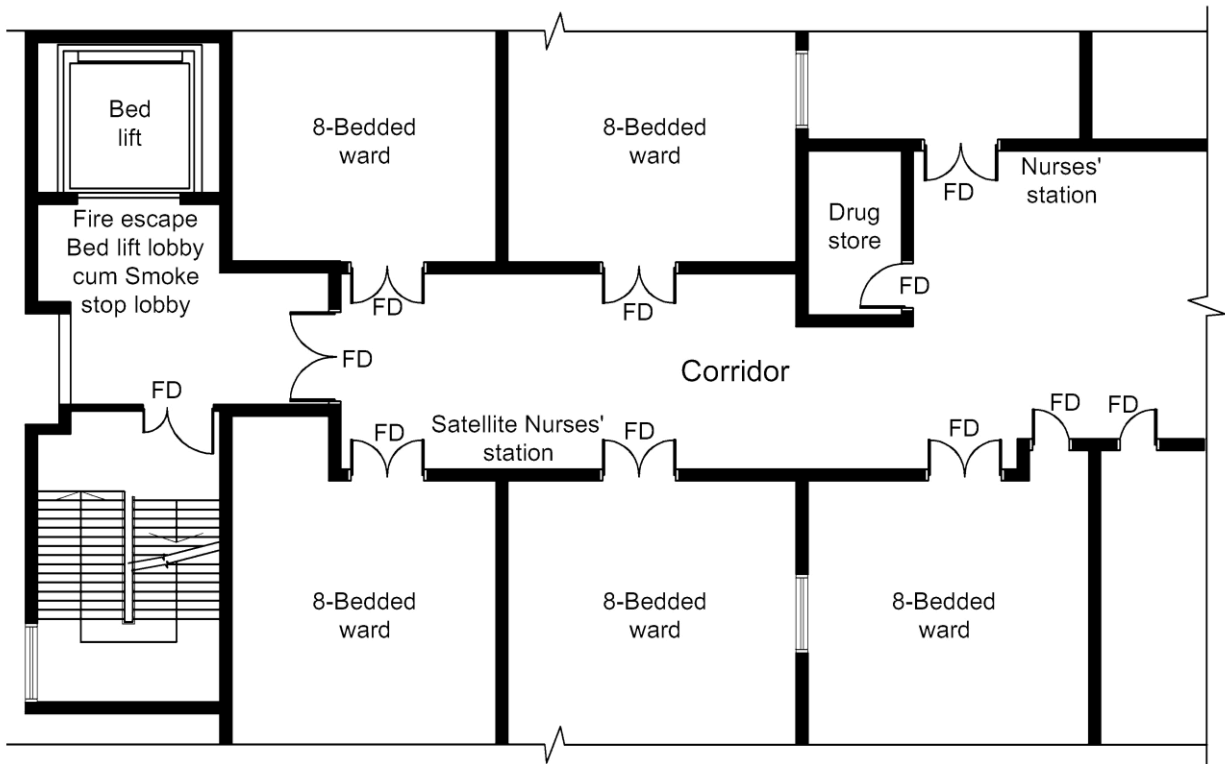

Diagram 2.5.1 (a)(viii)

The clear space within a smoke stop lobby shall not be less than 6m² to accommodate the people in wheelchairs, etc. In the above diagram the smoke stop lobby also performs as a fire escape bed-lift lobby. The floor area shall not be less than 9m² having a depth of min 2.5m perpendicular to the lift landing door.



2.5.1(a)(ix) Staircase landing width/depth

- (1) Exit staircases that serve patient accommodation floor and are to be used by patients in an emergency fire situation shall be designed to allow evacuation of patients on mattresses or stretchers.
- (2) The width of stair, landing width and depth shall comply with the following table:

Table 2.5.1 (a)(viii)(2)

STAIR WIDTH	MIN LANDING WIDTH	MIN LANDING DEPTH	
1000	2800	1900	Allows mattress or stretcher evacuation only (i.e. no pedestrian passing).
1250 1500	2800 3200	1900 1550	Allows mattress or stretcher evacuation and restricted ambulant passing
1750 2000	3600 4000	* 1350 * 1250	Allows mattress or stretcher evacuation and ambulant passing

- * For the purpose of calculating the exit capacity of the staircase, clear landing depth, instead of the clear stair width, should be taken.



EXPLANATIONS & ILLUSTRATIONS

2.5.1(a)(ix)

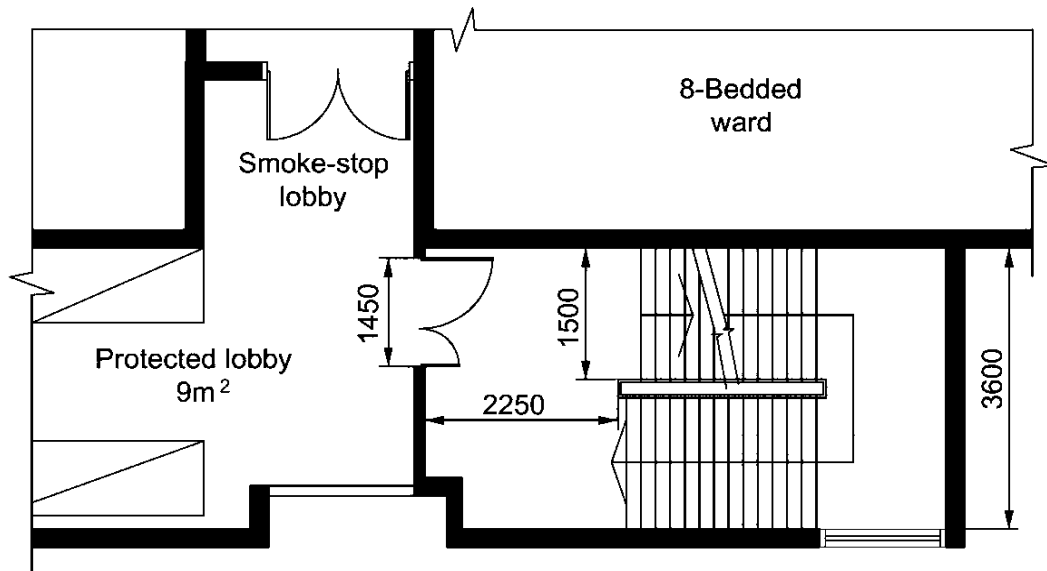

Diagram 2.5.1 (a)(ix)

Exit Capacity Calculation

Exit Door width: 1.45m

Unit of width=2.5

Person per unit width: 30persons

No of person provided: 30 X2.5= 75 persons

Stair Landing Depth: 1600mm and clear width of staircase: 1500m)

Unit of width: 3 (Using clear width of staircase as it is less than 1600mm)

Person per unit width: 15persons

No. of person provided: 15persons x 3 = 45 persons

No. of persons provided with means of escape for this staircase: 45 persons.

EXPLANATIONS & ILLUSTRATIONS

2.5.1(a)

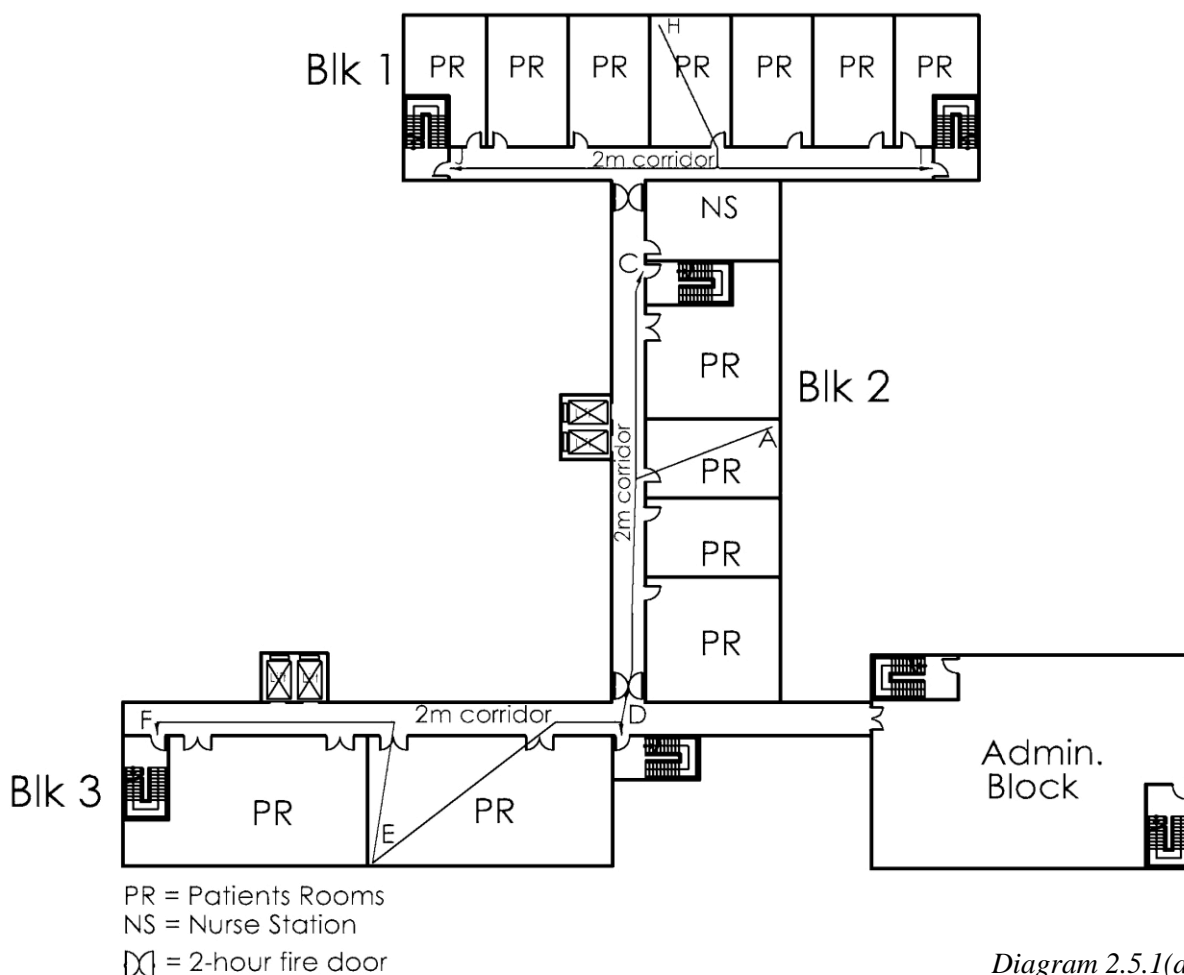

In diagram 2.5.1(a), each block is provided with at least 2 exit staircases, except for Blk 2, which is provided with only one exit staircase. This is because blocks 1 and 3 serve as areas of refuge for blk 2. The holding area in blocks 1 and 3 shall be based on the area of 2.8m²/person. See clause 2.5.3 and clause 1.2.4 and 2.2.6(f) for further explanation. Administration block is self-sufficient in the provision of exit staircases.

Owing to the design using area of refuge concept, the 2m wide corridors are required to be designed and maintained as open sided at all times. This will prevent the corridors from being filled with smoke during a fire emergency. The max. 2 way travel distances shall not exceed 30m or 45m if sprinklered. The direct distances for blk 1 and 3, from point H to I and point E to F respectively shall not exceed $\frac{2}{3}$ of 30m or $\frac{2}{3}$ of 45m, if sprinkler protected, for open plan layout. The direct distance for blk 2 from point A to D, entry point to block 3 as area of refuge, shall not exceed $\frac{2}{3}$ of 30m or $\frac{2}{3}$ of 45m if sprinkler protected, for open plan layout. Travel distances shall comply with Table 2.2A when internal partitioning work is introduced to create patients' rooms etc.

Where the occupant load of any room exceeds 50 persons, the doors to the room shall be made to swing outwards. Care should be taken to ensure that the corridor width is not affected.

2.5.1(b) A building or part thereof, used for the housing and nursing care of persons, who because of mental or physical incapacity, may be unable to care for their own needs and safety without the assistance of other persons. Such buildings shall include nursing and convalescent homes, homes for the aged and hospices.

(j) Fire safety requirements under Cl.2.5.1 (a) – Hospital shall be fully complied with.

EXPLANATIONS & ILLUSTRATIONS

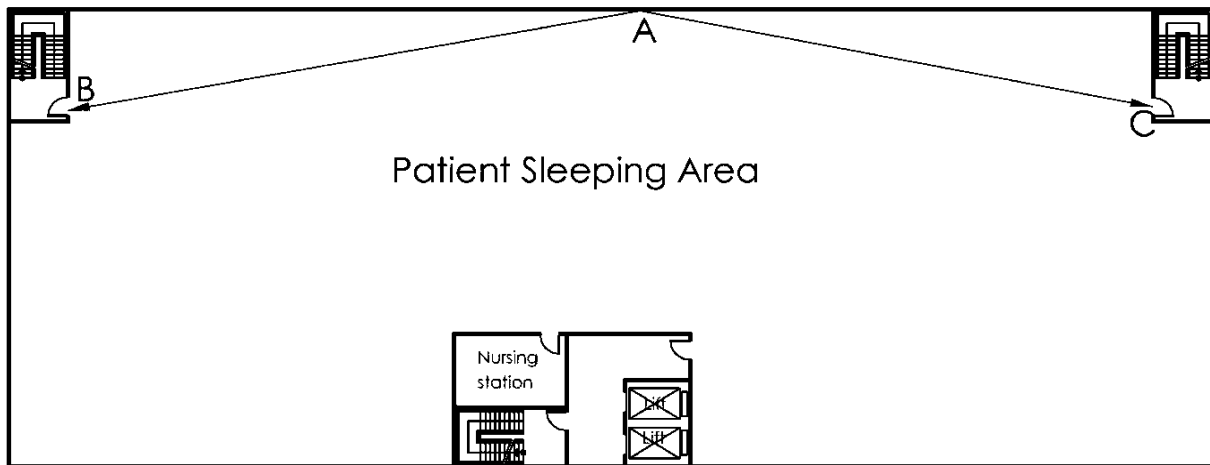

Diagram 2.5.1(b)-1

Nursing home shall also include hospices. Each floor of the patient sleeping area shall be provided with at least 2 exit staircases. Most of the occupants of nursing homes are considered as non-ambulatory or bedridden and incapable of self-preservation. As such, the homes shall be manned on a 24-hour basis by trained staff who knows how to evacuate the patients during a fire emergency.

In the above diagram 2.5.1(b), which shows an open plan layout, the direct distance requirements i.e. $\frac{2}{3}$ of travel distance shall be used to ensure that actual travel distances would comply with Table 2.2A when internal partitioning work is introduced to create patients' rooms etc. The direct distance from points A to B and A to C shall not exceed $\frac{2}{3}$ of 30m or $\frac{2}{3}$ of 45m if sprinklered.



EXPLANATIONS & ILLUSTRATIONS

2.5.1(b)

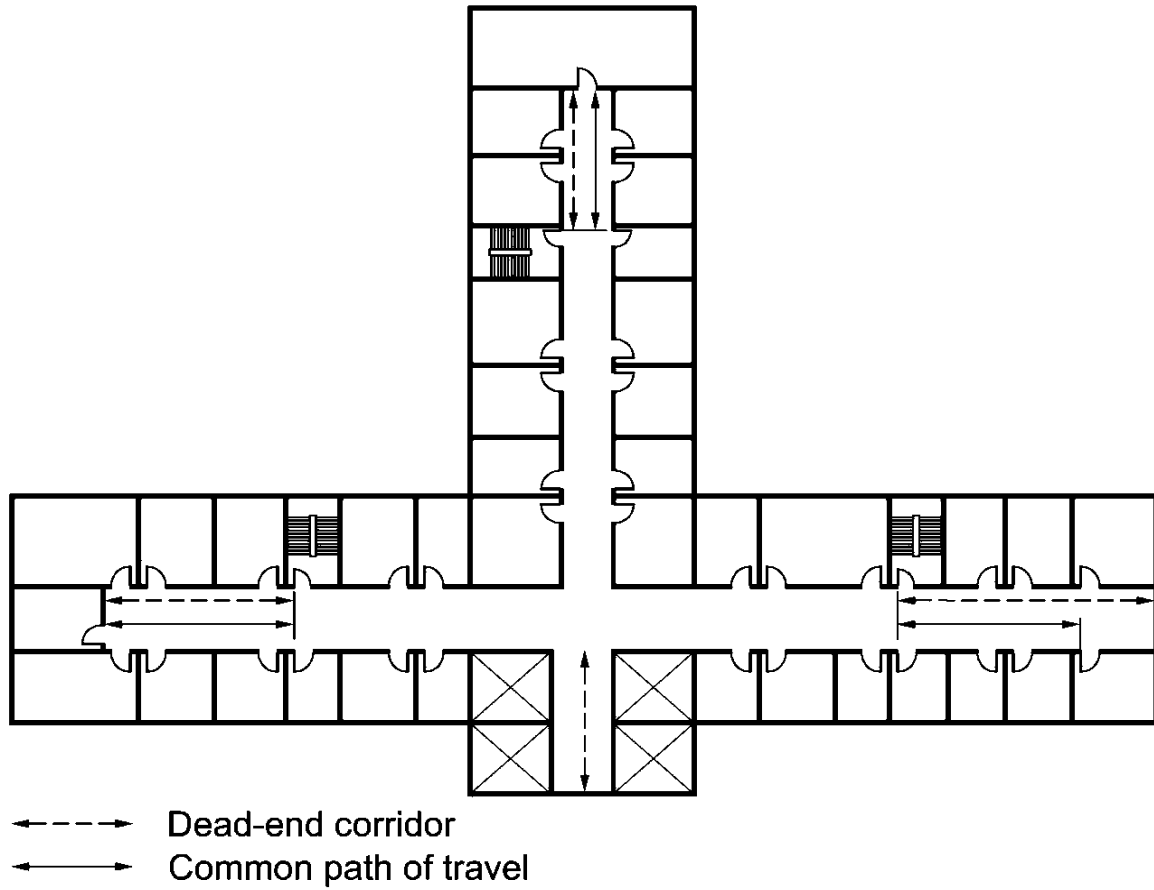

Diagram 2.5.1(b)-2

Path of travel and dead-end corridors in a nursing home.



2.5.1(c) Custodian Care Facility

Custodian Care Facility is a building or part thereof, used for the housing of persons who, because of age, or physical or mental disabilities, are unable to care for their self-preservation and safety. Such buildings shall include nurseries for children under 6 years of age and institutions for the mentally disabled.

- (i) Nurseries, including Childcare Centres, Kindergarten, infant care, if located within a building of mixed use, shall be compartmentalised from other spaces and occupancies by walls and doors having at least 1-hour fire resistance rating.

Where such facilities are located on the 1st storey, they shall be provided with direct access to the exterior of the building, and if located on the upper storey shall be sited adjacent to an exit staircase with direct dedicated access through smoke stop lobby to the staircase (minimum one exit staircase) or direct access without passing through the common areas to the exit staircase.

The requirement on the provision of fire compartmentation will not apply to any nursery, including Childcare Centres, Kindergarten, Infant Care that is located within a building protected by an automatic sprinkler system

- (ii) Institutions for the mentally disabled shall be designed with each storey having an area of refuge in accordance with Cl.1.2.4 and Cl.2.5.3. Fire safety requirements under Cl.2.5.1(a)-Hospital, shall be fully complied with, except Cl.2.5.1 (a) (v) on Provision of escape bed-lift and Cl.2.5.1 (a) (ix) on Staircase landing width/depth.

EXPLANATIONS & ILLUSTRATIONS

2.5.1(c)

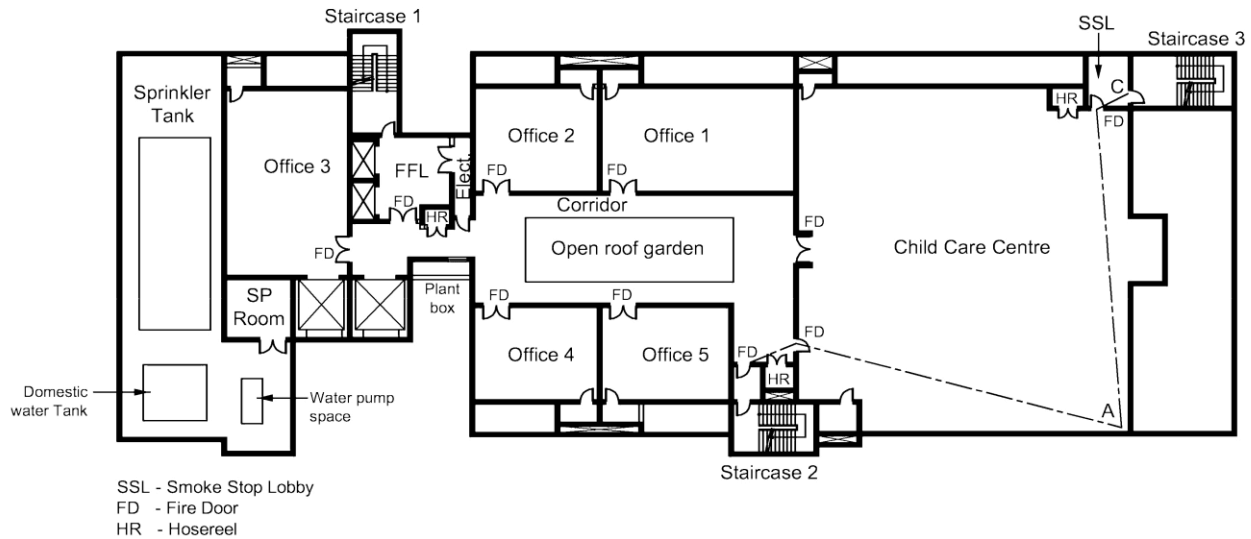

Diagram 2.5.1(c)

In the above diagram, a child care centre or nursery is located in one part of the office building. The child care centre shall be provided with direct access to at least 2 exit staircases. Routes leading to exit staircases outside the child care centre shall be made protected. It is recommended that child care centre should not be located in part of a building or storey of a building higher than 2nd storey. This is to allow the children and staff to have orderly evacuation during any emergency.

Occupants of custodian care facilities are generally capable of movement with limited assistance. They do not require to be evacuated in beds or stretchers, or bedsheets.

Institutions for mentally retarded patients would have locked exit doors, windows with security bars to confine and protect them. QPs shall consult the MFRS regarding the fire safety features in the security control system before submission of building plan. The max. 2 way travel distances shall not exceed 30m or 45m, if sprinkler protected. The direct distance from point A to B shall not exceed of $\frac{2}{3}$ of 30m or $\frac{2}{3}$ of 45m if sprinkler protected for open floor plan layout.



2.5.1(d) Supervisory Care Facility

A building or part thereof, used for the housing, on a 24 hour basis, of mental health patients who may be capable of self-preservation but require supervision and are receiving therapy, training or other health related care and for whom there may be security measures not under their control.

- (i) Fire safety requirements under Cl.2.5.1 (a) – Hospital, shall be fully complied with, except Cl.2.5.1 (a)(v) on Provision of escape bed-lift and Cl.2.5.1(a)(ix) on Staircase landing width/depth.

EXPLANATIONS & ILLUSTRATIONS

No illustration.

Supervisory care facility used for housing for 4 or more mental health patients would require security measures such as locked exit doors, windows with security bars etc. It must be recognised that such measures, which contravenes the fire code would be necessary to restrain the patients and for their own safety.

The facility would be manned by trained staff on a 24 hours basis. QPs shall consult MFRS on the provision of locking devices to exit doors and how such doors would be released in times of emergency to allow orderly evacuation of patients before making building plan submission.

2.5.1(e) Ambulatory Health Care Centre

A building or part thereof, used for providing services on an out-patient basis for:

- (i) treatment for patients which would render them incapable of taking action for self preservation or safety under emergency conditions without assistance from others, such as haemodialysis units, or
- (ii) surgical treatment requiring general anaesthesia
- (iii) Ambulatory Health Care Centre, if located within a building of mixed use, shall be compartmentalised from other tenants and occupancies by walls and doors having at least 1-hour fire resistance rating. The Ambulatory Health Care Centre shall be provided with its own means of escape to at least one exit staircase.
- (iv) Fire Safety requirements under (a) – Hospital, shall be fully complied with except Cl.2.5.1 (a)(iii) on Provision of area of refuge for horizontal evacuation, Cl.2.5.1(a)(v) on Provision of escape bed-lift and Cl.2.5.1(a)(ix) on Staircase landing/depth.

EXPLANATIONS & ILLUSTRATIONS

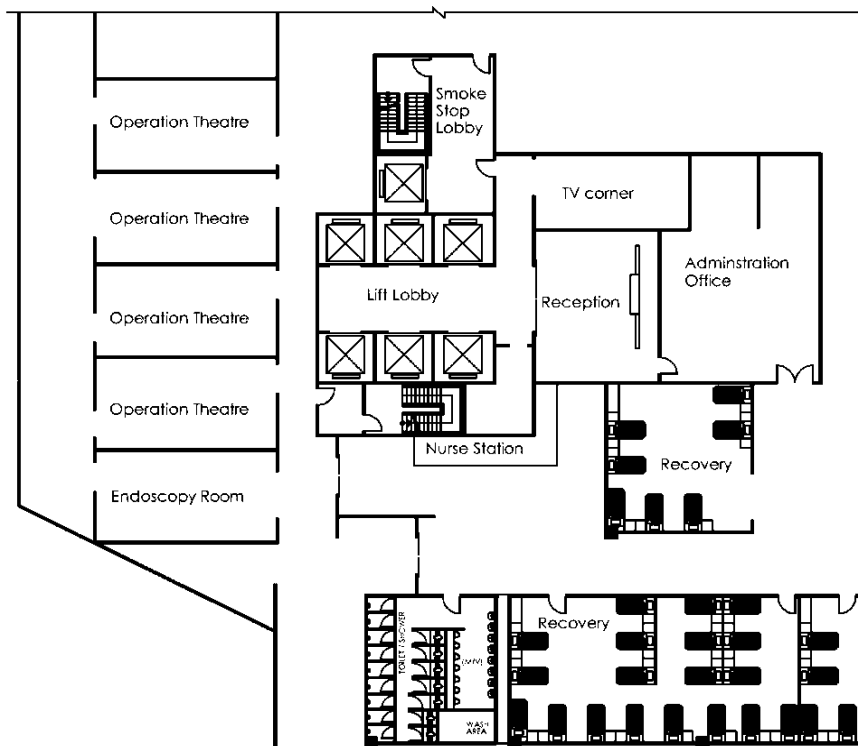

Diagram 2.5.1(e)

In an ambulatory health care centre, some of the patients are not capable of perceiving threats and taking appropriate action for self-preservation under emergency conditions without assistance from others, such as haemodialysis units or freestanding emergency medical units.

Staff shall be trained to carry out evacuation procedures during a fire emergency. The building or part of the building used as an ambulatory health care centre shall be provided with at least 2 exit staircases.



2.5.1(f) Outpatient clinics that do not fall under categories described above.

Fire safety requirements under Cl.2.5.1(a) are not applicable, except on the provision of separate compartment, which shall comply with cl.3.2.5(b).

EXPLANATIONS & ILLUSTRATIONS

No illustration.



CHAPTER 2

2.5 HEALTH CARE OCCUPANCY

2.5.2 Number of Doors

- (a) In compliance with the provisions of Cl.2.2.10 for number of doors from rooms and spaces, two openings for doors located remote from each other shall be provided for any patient's sleeping room or suite of patients' sleeping room having an occupancy load exceeding 50 persons, and
- (b) Rooms and spaces with occupancy of 50 persons or more shall comply with the requirements of Cl.2.8.2 for Assembly Occupancy.

EXPLANATIONS & ILLUSTRATIONS

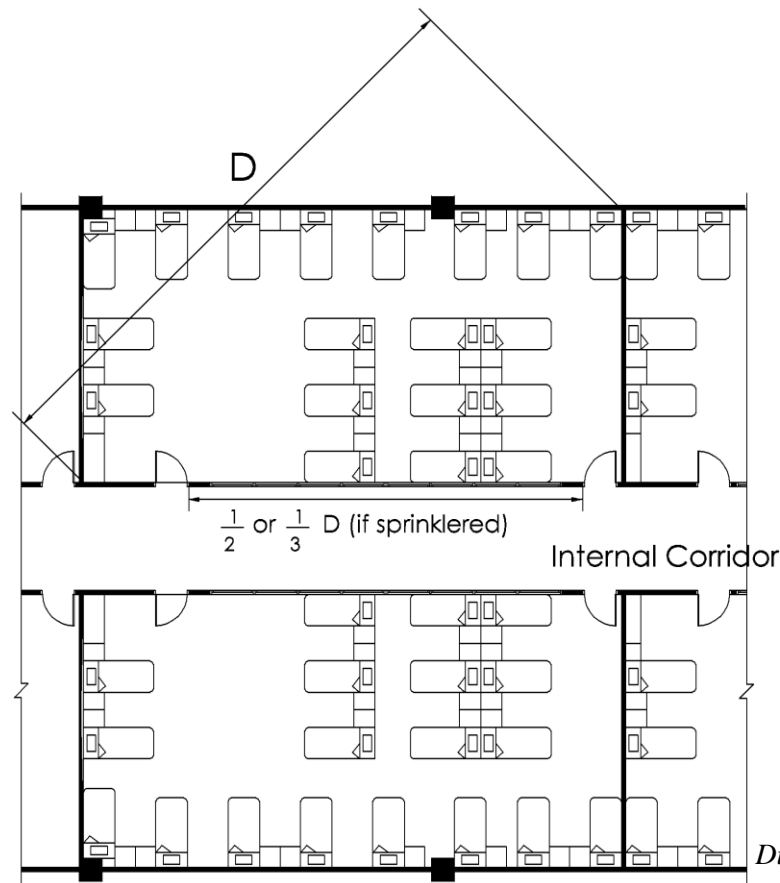

Diagram 2.5.2

Any patients' ward or suite of patient's sleeping room having an occupant load of more than 50 persons shall be provided with 2 exit doors or staircases located as remote from each other as possible. The occupant load shall be based on:

$$\frac{\text{Gross floor area}}{\text{Occupant load factor of } 10\text{m}^2 \text{ per person}} = \text{Occupant load}$$

CHAPTER 2

2.5 HEALTH CARE OCCUPANCY

2.5.3 Area of refuge - Occupancy load

Where Area of Refuge serves as required exit, the calculation of area for refuge occupants shall be based on the following:

- (i) Hospitals - 2.8 m²/person.
- (ii) Nursing Homes - 2.8 m²/person.
- (iii) Custodian Care Facility - 1.4 m²/person.
- (iv) Supervisory Care Facility - 0.56 m²/person.
- (v) Ambulatory Health Care Centre - 1.4 m²/person.

On storey of hospitals or nursing homes where patient accommodation is not provided, at least 0.56 m² per occupant shall be taken for the calculation of the area for refuge of occupants.

EXPLANATIONS & ILLUSTRATIONS

Example (1) of health care occupancy layout

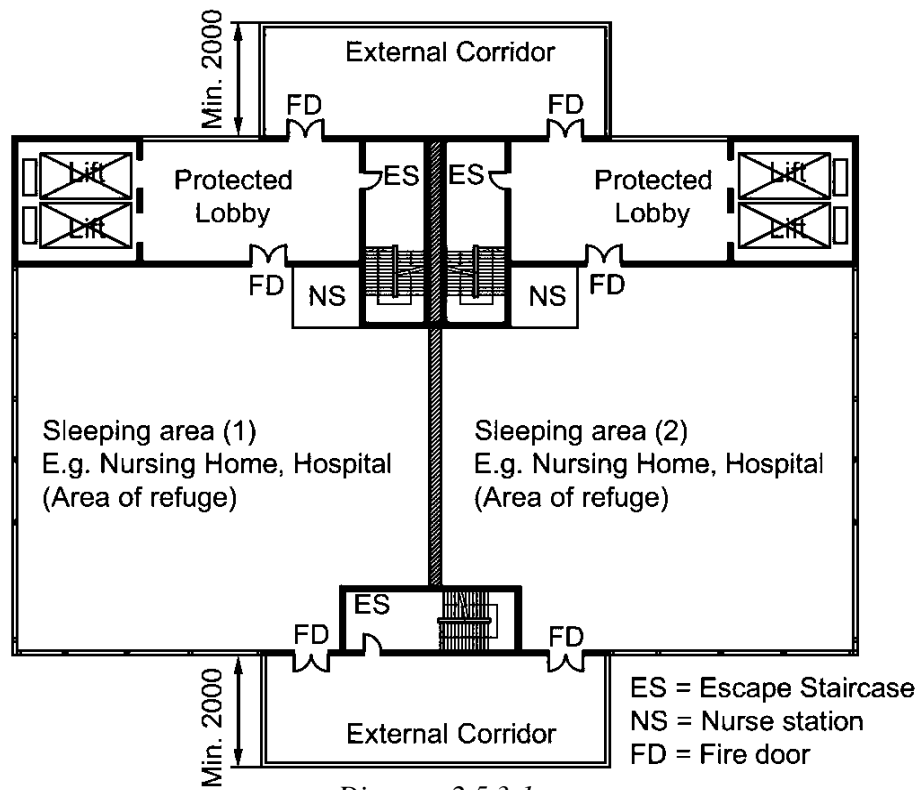

Diagram 2.5.3-1

EXPLANATIONS & ILLUSTRATIONS

2.5.3

Example (2) of health care occupancy layout

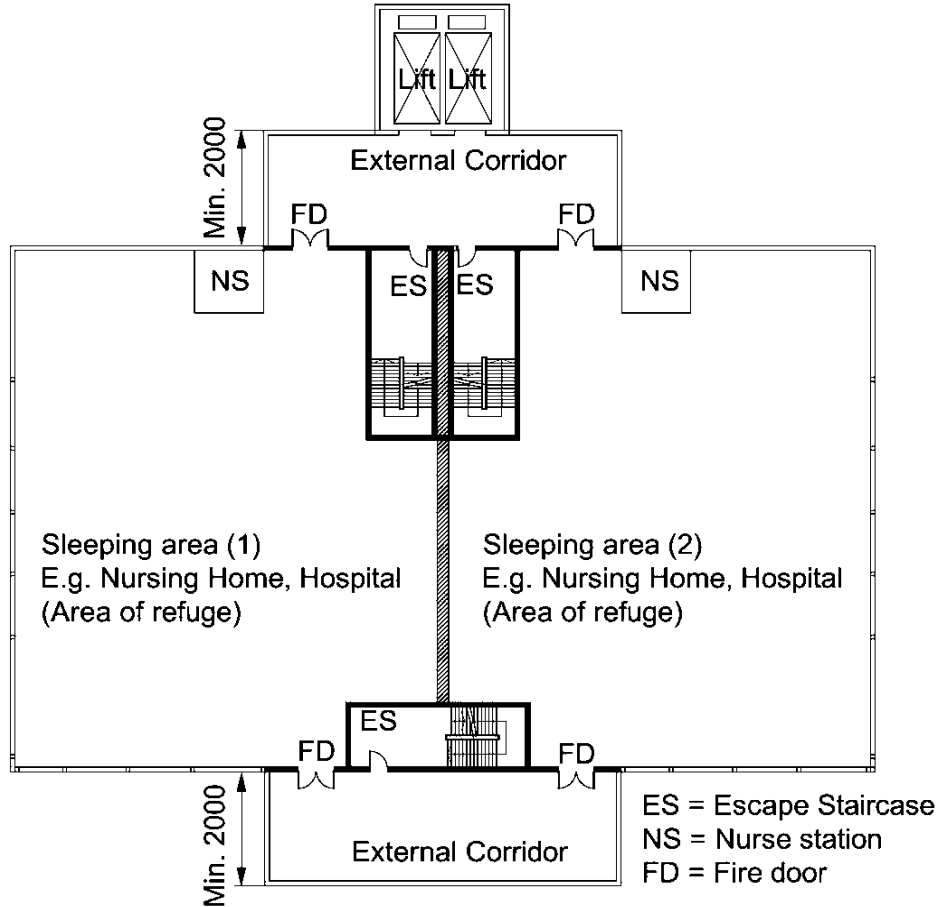

Diagram 2.5.3-2

- a) Access to an area of refuge shall be along defined means of egress provided with ramp or level floor, not stairs.
- b) An area of refuge is a temporary holding area and is provided with two-way voice communication system between the area of refuge and the Fire Command centre. It is intended to be used as a staging area that provides relative safety to its occupants. Thus taking refuge within such an area is a stage of the total evacuation process; a stage between exit from the immediately threatened area and exit to a public exterior space at grade level.

**EXPLANATIONS & ILLUSTRATIONS****2.5.3**

c) The reasons for adopting an occupant load factor of 2.8m²/person for hospitals and nursing homes are :

- i) Circulation spaces required for movement of patients and the beds are required to be taken into consideration;*
- ii) Patients in critical care areas might be connected to life-supporting equipment, making movement of patient confined to the bed difficult thereby increasing the evacuation time, and*
- iii) During a fire, the emergency evacuation of patients in non-ambulatory health care facility can be an inefficient and time-consuming process, taking into consideration the staff to patients ratio, the presence of beds, equipment causing obstruction to the transferring of patients from the ward area to the area of refuge.*

d) The provision of area of refuge is not compulsory, but we would recommend it for the following reasons :

- i) fewer staircases need to be built;*
- ii) patients who are non-ambulatory or bedridden can be transferred to safe holding area in an emergency ; and*
- iii) passenger/patients lifts may be used as a supplemental facility for evacuation purpose if they are suitably designated, located, protected and provided with independent emergency power supply similar to that provided for fire lifts. For such arrangement QPs shall consult MFRS before making building plan submission.*



CHAPTER 2

2.6 OFFICE/SHOP/FACTORY/WAREHOUSE OCCUPANCY

2.6.1 Number of exit staircases or exits per storey

In an office, shop, factory and warehouse building, at least two independent exit staircases or other exits shall be provided in compliance with the requirements of Cl.2.2.11, except that one exit staircase is permitted to serve the upper storeys, if the building is of non-combustible construction and not exceeding four storeys, subject to:

- (a) The maximum travel distance on any storey complying with column (ii) of Table 2.2A; and
- (b) Exit staircase conforming to the requirements of Cl.2.3.3; and
- (c) The gross floor area of each upper storey of shop, factory and warehouse building not exceeding 200m², including service ducts, lift shafts, toilets, staircase etc; and
- (d) The habitable height of the shop, factory or warehouse building not exceeding 15m; and
- (e) Access to the building for fire-fighting appliances being provided for in compliance with the requirements in Chapter 4.

EXPLANATIONS & ILLUSTRATIONS

Conditions for Single Exit Staircase

AC or BC < 15m (30m if sprinklered)

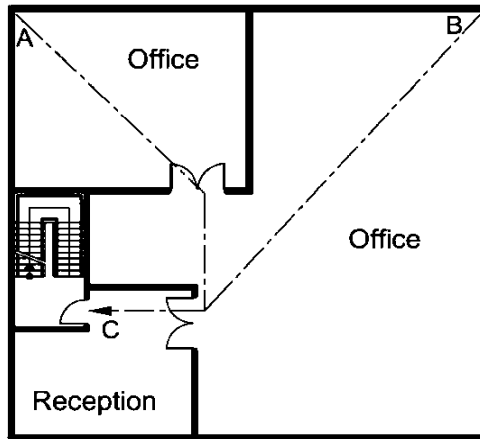

Diagram 2.6.1-1

- OL δ 50 persons (or 10 persons^{*})
- One-way travel distance AC or BC δ 15m or 30m (if sprinkler protected) or δ 10m or 20m respectively*
- Floor area δ 200m²
- storey height δ 4 storeys or habitable height of building δ 15m whichever is lower.

* For high hazard building if allowed by MFRS

EXPLANATIONS & ILLUSTRATIONS

2.6.1

AB < 15m (25m if sprinklered)

Diagram 2.6.1-2

- Occupant Load δ 50 persons
- One-way travel distance AB, δ 15m or 25m (if sprinkler protected)
- Floor area δ 200 m² (not applicable to office)
- Gross floor area includes service ducts, lift shafts, toilets and staircase.
- Building shall not exceed 4 storeys or habitable height of 15m whichever is lower.

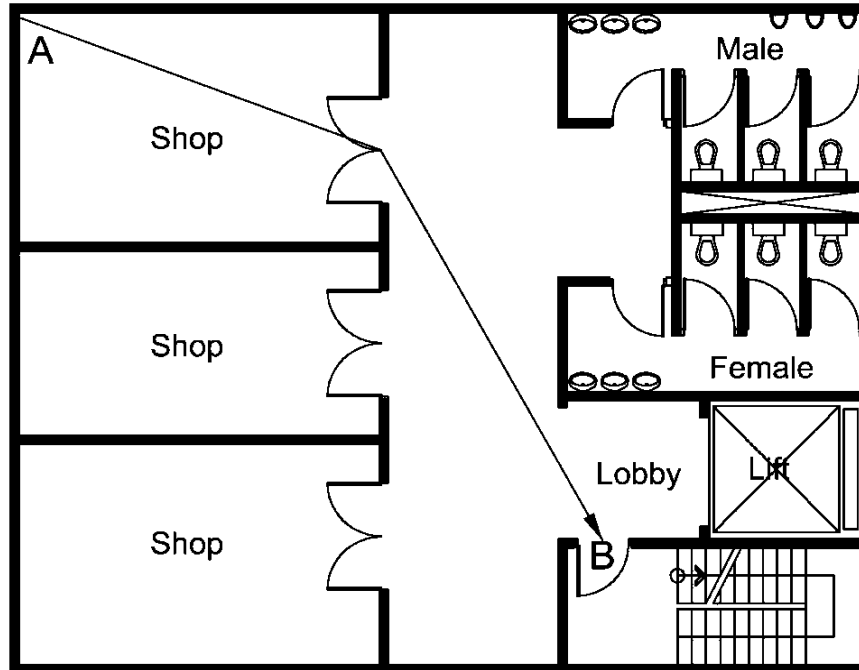

EXPLANATIONS & ILLUSTRATIONS

2.6.1

Office – Max. 4 storey

AC, BC or DE < 15m (30m if sprinklered)

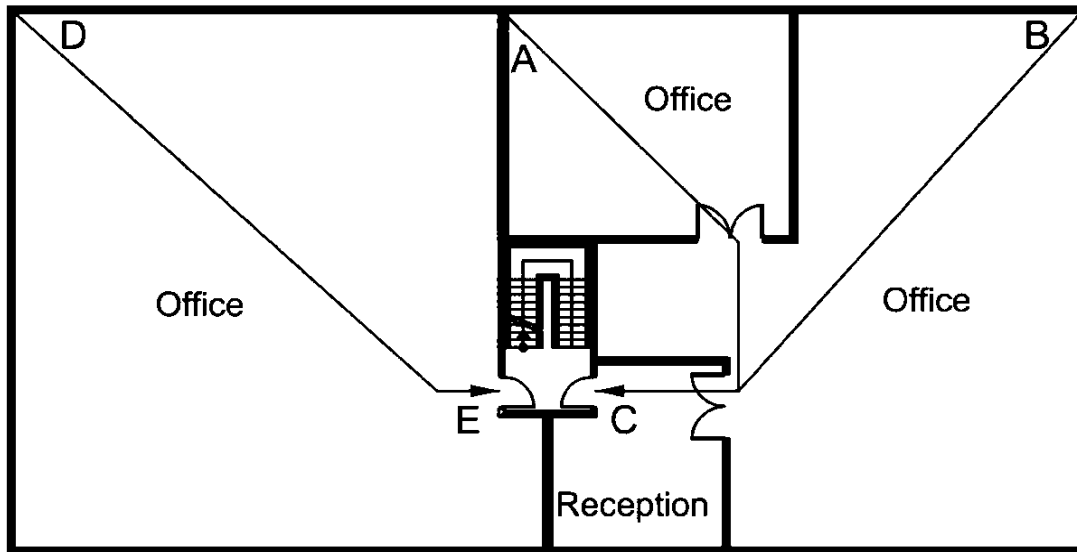

Diagram 2.6.1-3

- One-way travel distance AC, BC, δ 15m or 30m (if sprinkler protected)
- DE shall be treated as one-way direct distance as the floor space is an open floor plan. The direct distance for DE shall be $\frac{2}{3} \times 15\text{m}$ or $\frac{2}{3} \times 30\text{m}$, if sprinklered.



EXPLANATIONS & ILLUSTRATIONS

2.6.1

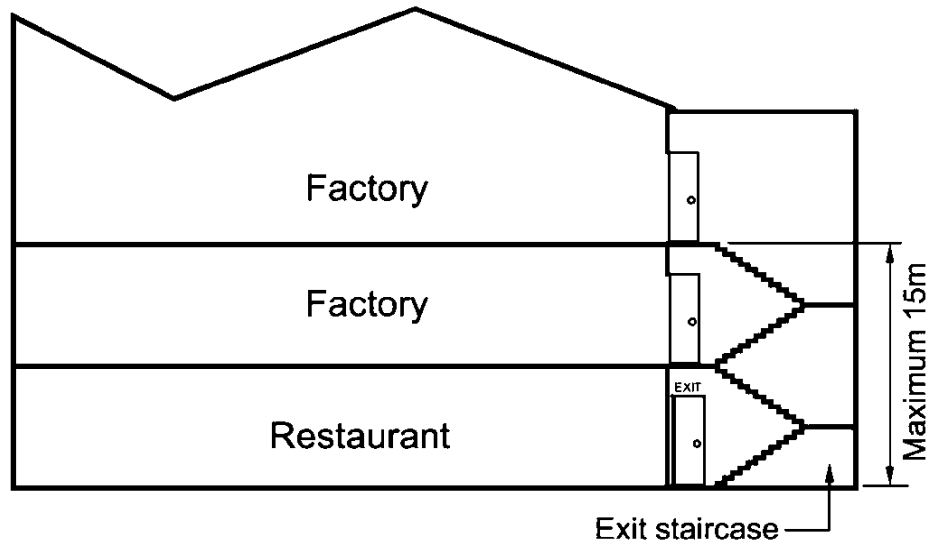

Diagram 2.6.1(d)-1

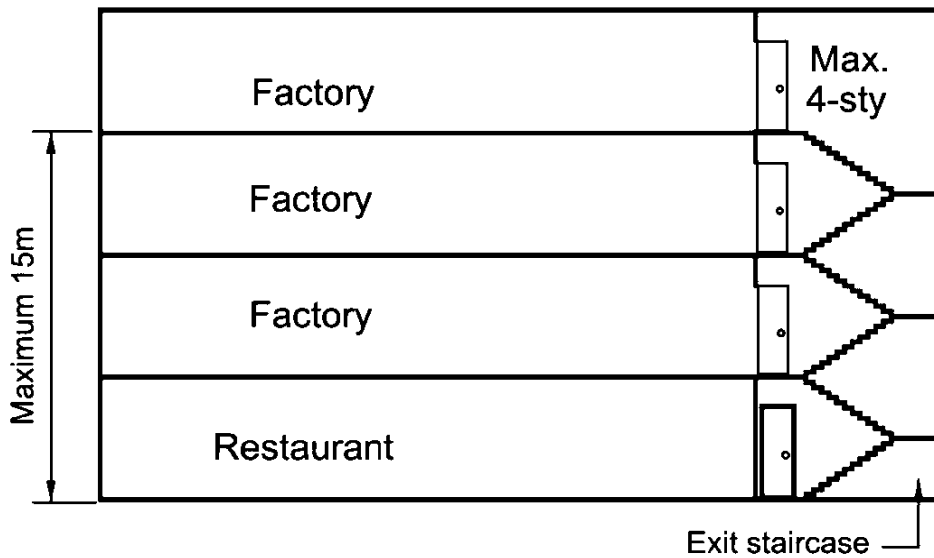

Diagram 2.6.1(d)-2



CHAPTER 2

2.6 OFFICE/SHOP/FACTORY/WAREHOUSE OCCUPANCY

2.6.2 Mezzanine floor

In factory unit with mezzanine floor, one open stair is allowed to serve the mezzanine floor, provided:

- (a) there is only one mezzanine floor above the main factory per factory unit; and
- (b) the mezzanine and open stair shall be of fire resistant construction, the stair shall have a minimum width of 1m; and
- (c) the maximum travel distance measuring from remote point on the mezzanine floor to the exit access door of the factory unit on the main factory floor shall comply with column (ii) of Table 2.2A; and
- (d) the area of the mezzanine floor shall not exceed 60m², including service ducts, toilets, staircase and etc; and
- (e) the habitable height of mezzanine floor shall not exceed 24m; and
- (f) mezzanine floor shall only be used for factory, store and/or ancillary office.

EXPLANATIONS & ILLUSTRATIONS

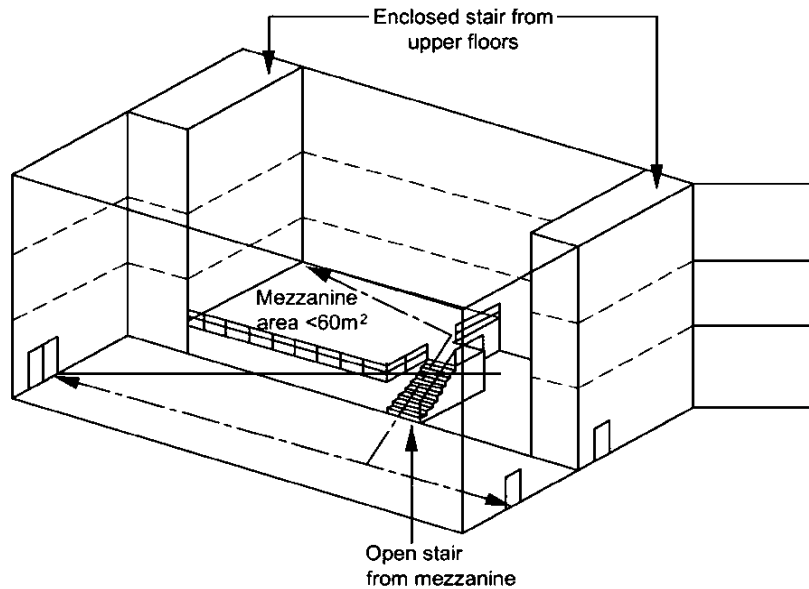

Mezzanine egress through that floor.

Diagram 2.6.2-1



EXPLANATIONS & ILLUSTRATIONS

2.6.2

The mezzanine floor and open staircase shall be fire resistant construction, similar to the compartment floor.

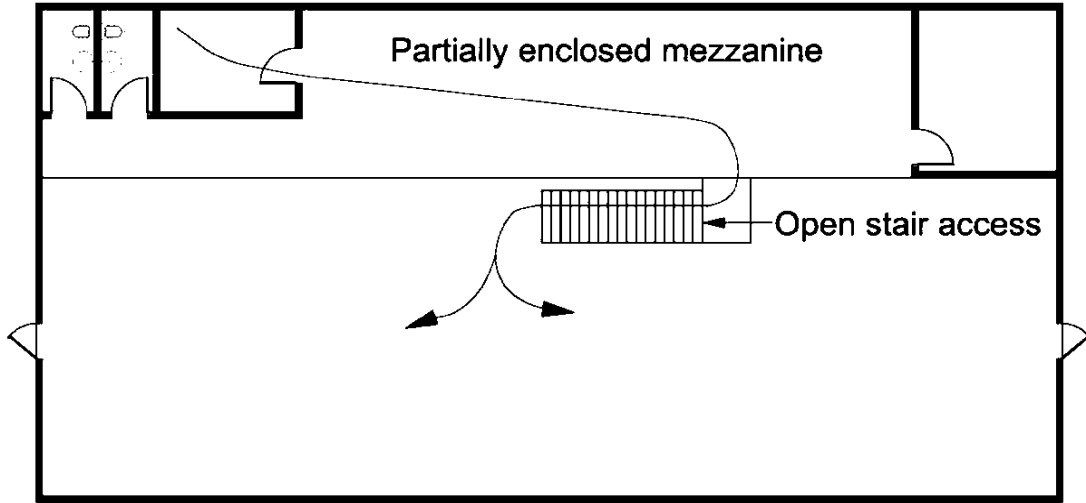

Open mezzanine

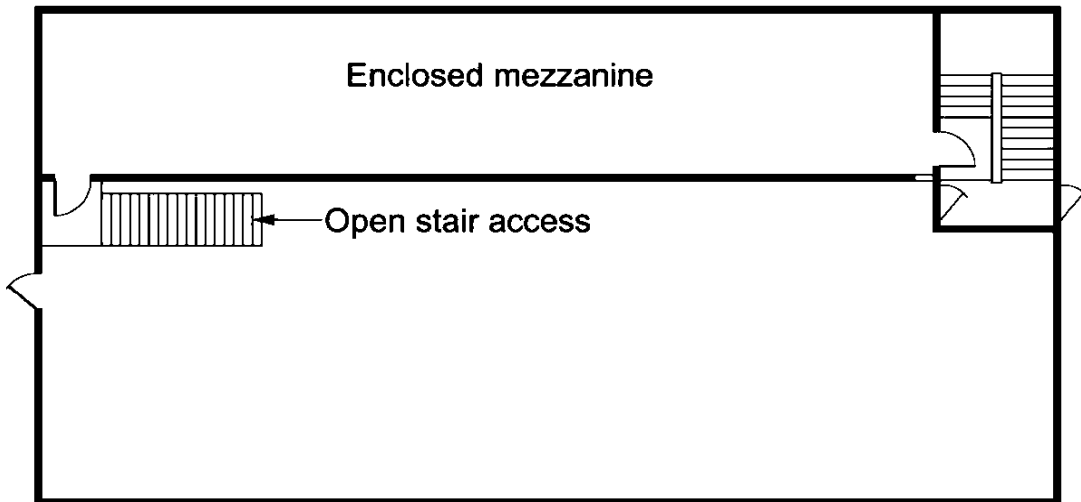

Enclosed mezzanine

Diagram 2.6.2-2

The allowable common path of travel were exceeded, the mezzanine would require a second, remote exit access.



EXPLANATIONS & ILLUSTRATIONS

2.6.2

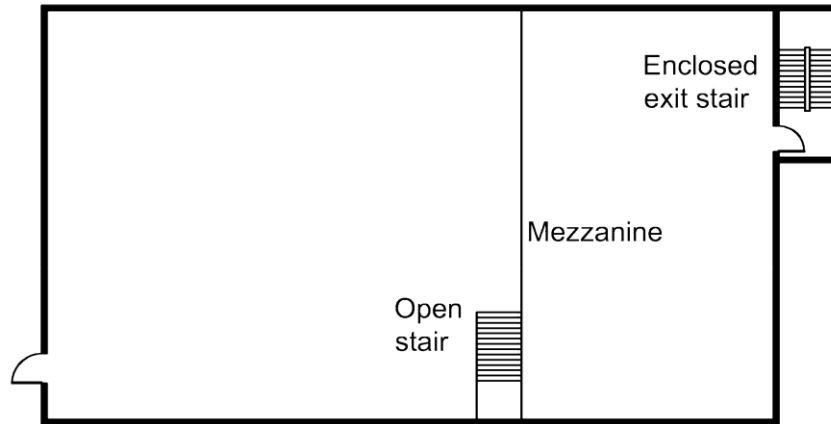

(a)

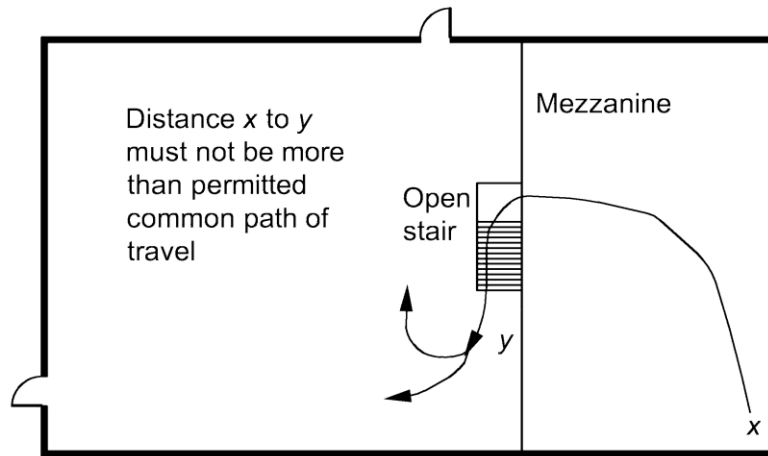

(b)

Diagram 2.6.2-3

Egress from mezzanine



CHAPTER 2

2.7 HOTELS, BOARDING HOUSES, SERVICES APARTMENTS, STUDENT HOSTELS, BACKPACKERS HOTEL

2.7.1 Internal corridor to guestroom or accommodation unit

Guestroom or accommodation unit with access through an internal corridor shall comply with the requirements as follows:

- (a) Guestroom or accommodation unit shall be separated from the internal corridor by a wall having fire resistance of at least 1 hour, and
- (b) Doors opening into internal corridors shall have fire resistance of at least half an hour and fitted with automatic self-closing device to comply with the requirements of Cl.3.9.2, and

EXPLANATIONS & ILLUSTRATIONS

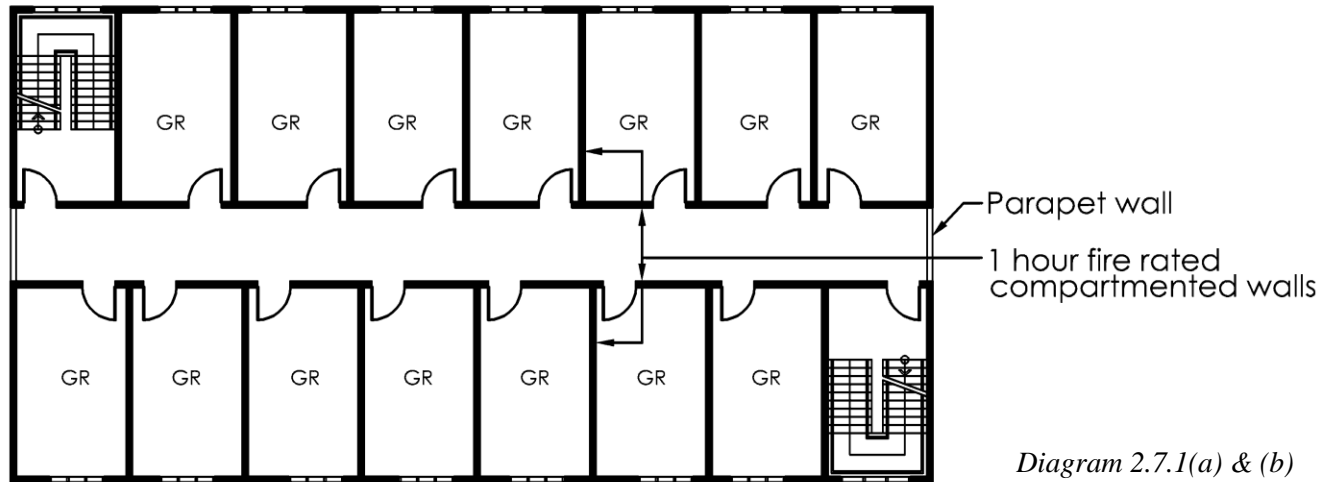

GR : Guest Rooms
 ⌞ : Min. 1/2 hour fire door fitted with automatic self-closing device

Each guestroom is treated as a fire compartment. Walls facing the corridor and between guestrooms may be constructed of fire rated materials other than masonry. They shall be of full height carried right-up to the underside of the soffit of the floor slab above or to an imperforate fire rated ceiling or to the roof coverings.



(c) Internal corridors shall be naturally ventilated with fixed openings in an external wall, such ventilation openings shall comply with Cl.2.2.13 (i) & (iv), and internal corridors which cannot be naturally ventilated shall be pressurised to comply with the requirements in Chapter 7.

EXPLANATIONS & ILLUSTRATIONS

2.7.1

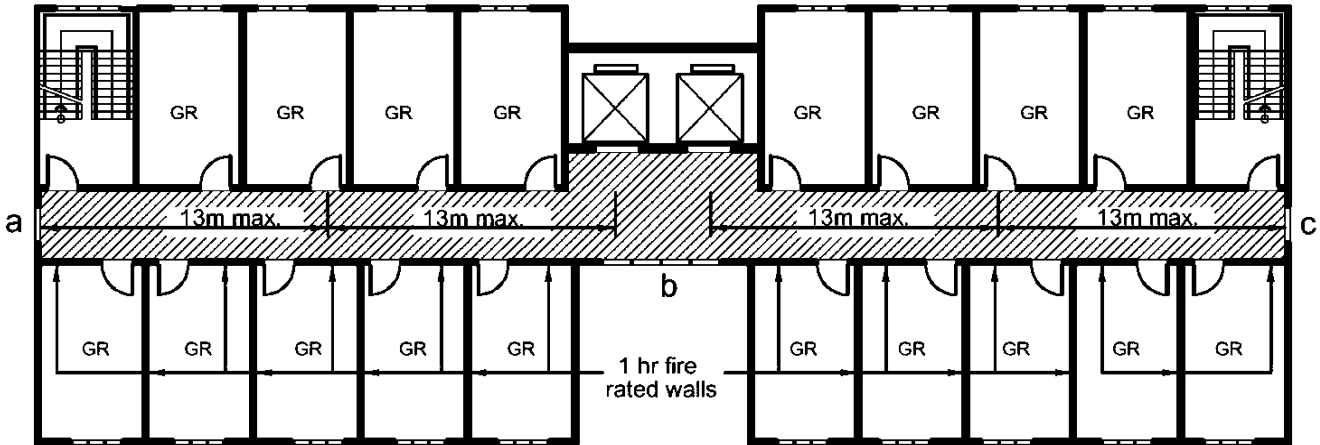



-  : Min. 1/2 hr fire door
- GR : Guest room
-  : Internal corridor

Diagram 2.7.1(c)

For natural ventilation to the internal corridor, the total fixed openings (a + b + c) shall not be less than 15% of the area of the internal corridor. Alternatively, internal corridor can be provided with mechanical ventilation and pressurised to comply with the requirements in Chapter 7. No part of the corridor shall be at a distance of more than 13m from any ventilation openings.



(d) Other rooms or spaces which open into or form part of the guestroom or accommodation unit corridor which may prejudice the means of escape provision shall be required to be compartmented to the same extent as the guestroom or accommodation unit.

EXPLANATIONS & ILLUSTRATIONS

2.7.1

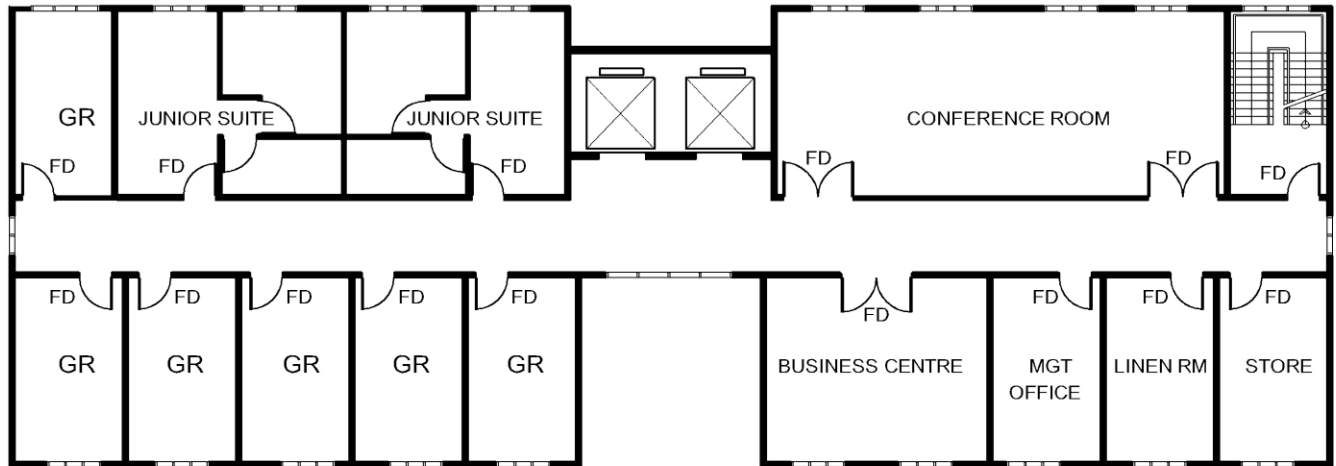

Diagram 2.7.1(d)

FD : Min. $\frac{1}{2}$ hr fire door
GR : Guest room

Other rooms or spaces include linen room, which required to be fire compartmented with 1-hour fire rated enclosure and $\frac{1}{2}$ hour fire door respectively. Lounge area, business centre etc. should be treated as guestroom. Therefore, compartmentation is required.

CHAPTER 2

2.7 HOTELS, BOARDING HOUSES, SERVICES APARTMENTS, STUDENT HOSTELS, BACKPACKERS HOTEL

2.7.2 External corridor

Guestroom or accommodation unit with access through an external corridor shall comply with the requirements as follows:

- (a) Guestroom or accommodation unit shall be separated from the external corridor by a wall having fire resistance of at least 1 hour, except that ventilation openings of non-combustible construction may be fixed at or above a level of 1.1m, measured from the finished floor level of the external corridor to the sill height of the opening, and
- (b) Doors opening into the external corridor shall not be required to have fire resistance rating, and
- (c) External corridors shall conform to the requirements of external exit passageway in respect of minimum width of 1.5m, changes in floor level, maximum roofed-over width, and enclosure on the open side.

EXPLANATIONS & ILLUSTRATIONS

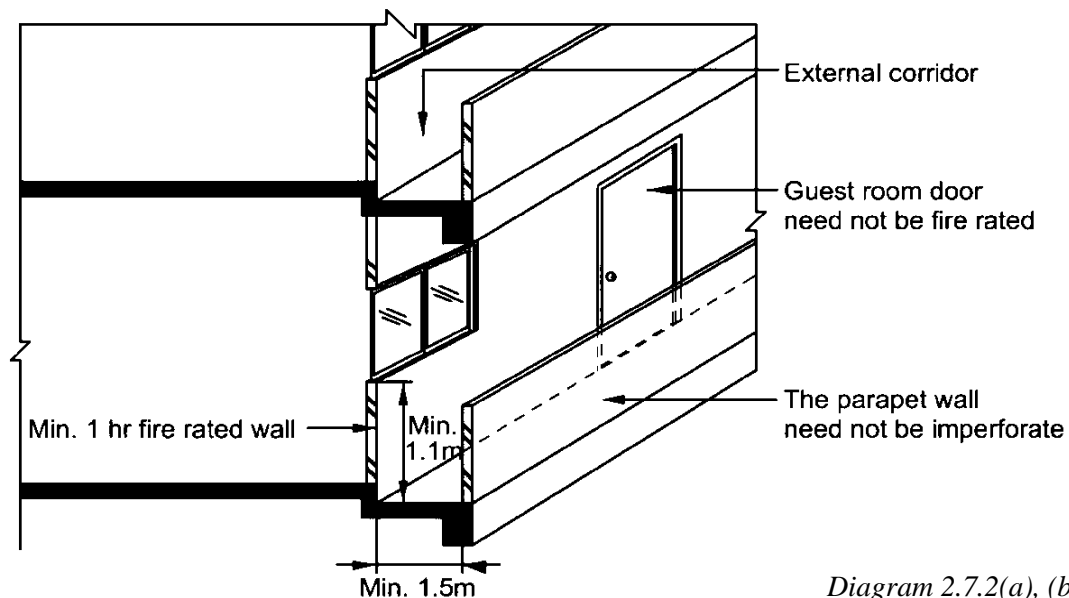

The depth of the roof protection over the corridor shall not exceed 3m. The open side of the corridor shall not be installed with glazing, blinds, etc. The external corridor refers to corridor which opens to the external and not to atrium.



CHAPTER 2

2.7 HOTELS, BOARDING HOUSES, SERVICES APARTMENTS, STUDENT HOSTELS, BACKPACKERS HOTEL

2.7.3 Measurement of travel distance

The travel distance shall be measured from the most remote point of a guestroom or accommodation unit or suite to the exit door of an exit staircase, exit passageway or exterior open space.

EXPLANATIONS & ILLUSTRATIONS

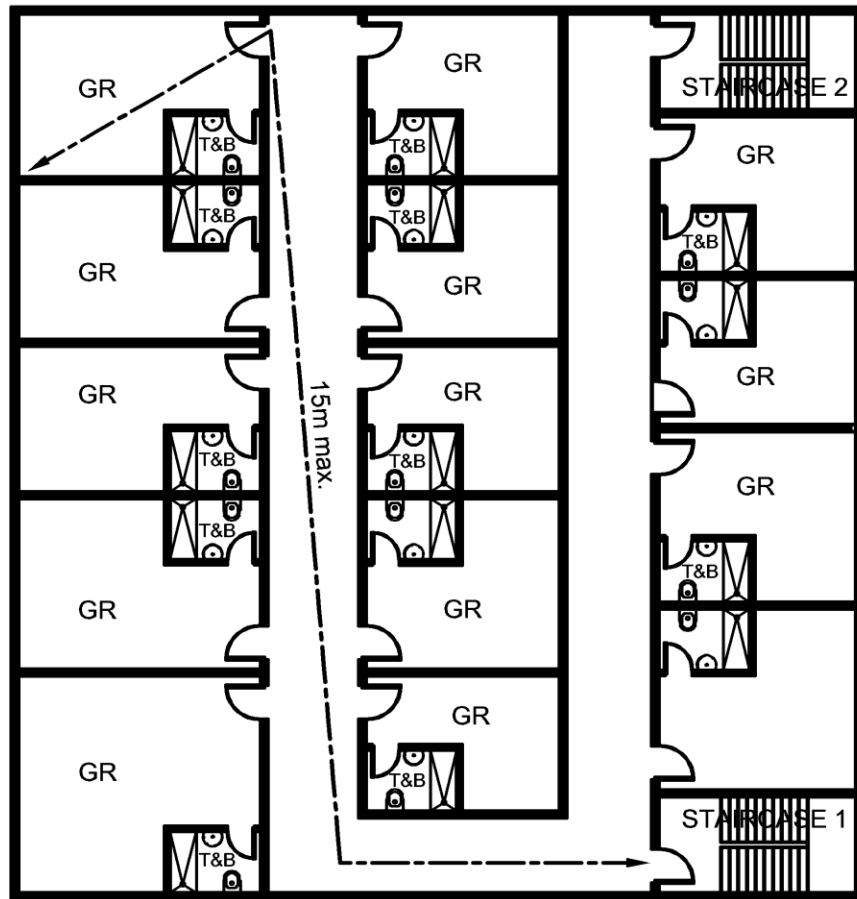

Diagram 2.7.3-1

Unsprinkler

One-way travel distance from most remote point of guest room to exit staircase is 15m.

EXPLANATIONS & ILLUSTRATIONS

2.7.3

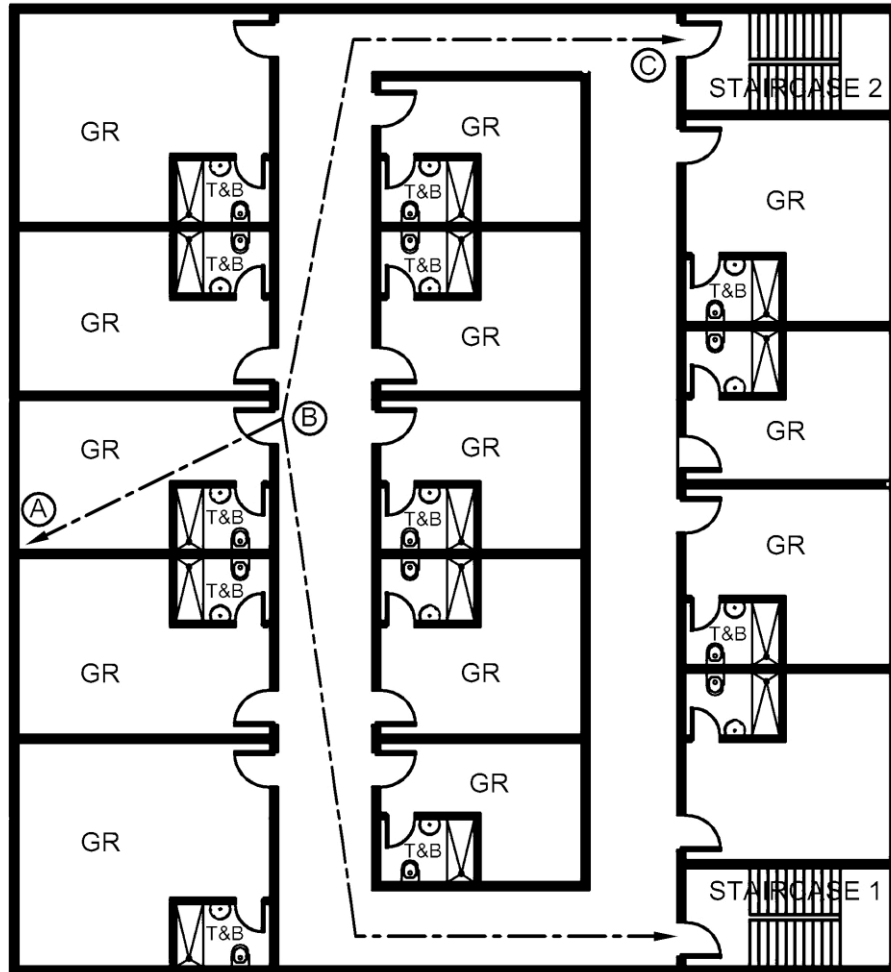

Diagram 2.7.3-2

Travel distance for Non-sprinkler protected building

A to B is considered as one-way travel distance and it shall be not more than 15m. In computing the two-way travel distance, the escape route from point A to C (via B) shall not exceed 30m.

Travel distance for sprinkler protected building

“A to B is considered as one-way travel distance and it shall not be more than 20m. In computing the two-way travel distance, the escape route from point A to C (via B) shall not exceed 60m.”



CHAPTER 2

2.7 HOTELS, BOARDING HOUSES, SERVICED APARTMENTS, STUDENT HOSTELS, BACKPACKERS HOTEL

2.7.4 Spacing of smoke barrier

- (a) Internal corridors which are not naturally ventilated shall be subdivided by smoke barriers into the following lengths:
 - Building protected by sprinkler system .. 45m
 - Building not protected by sprinkler system .. 30m

EXPLANATIONS & ILLUSTRATIONS

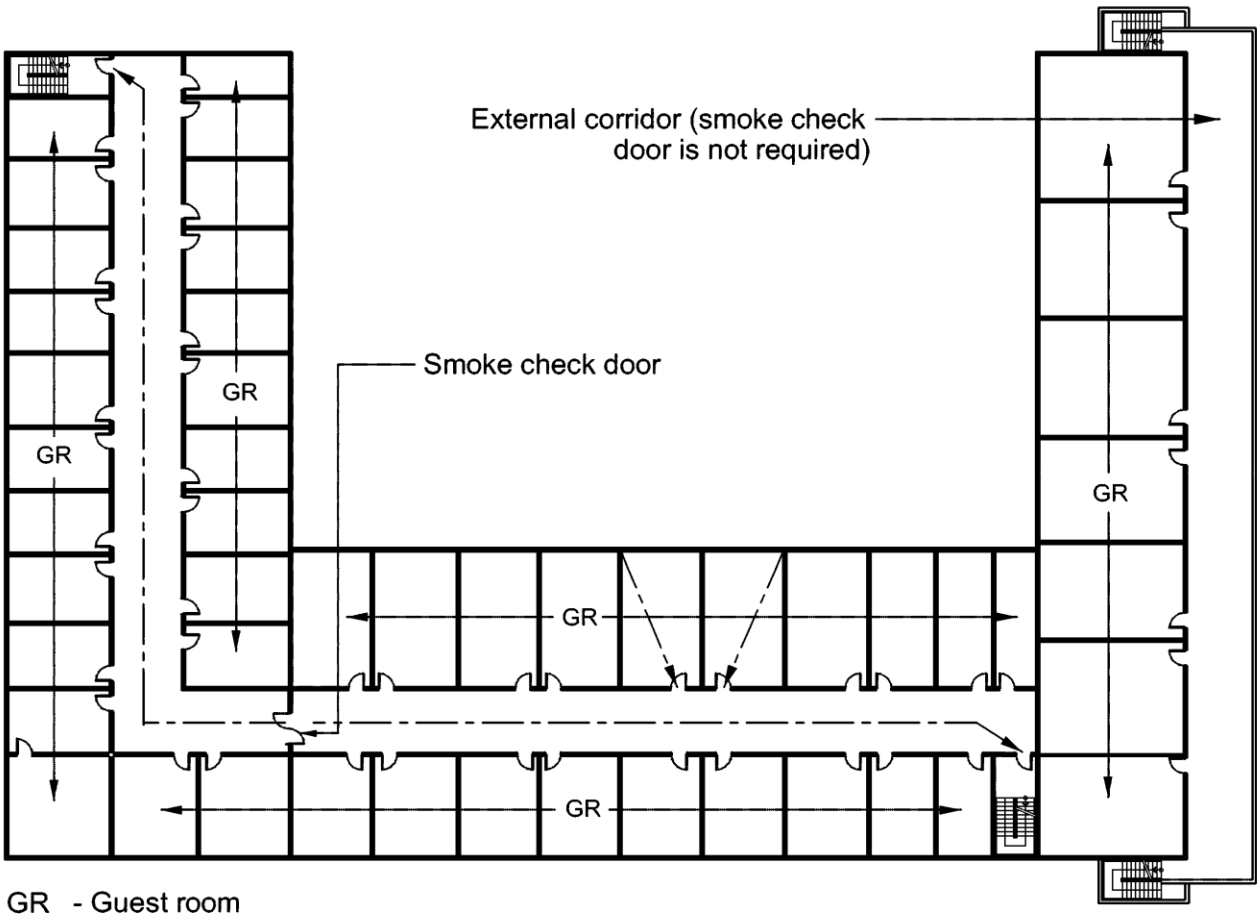

Diagram 2.7.4-1

For dead-end definition please refer to clause 1.2.17

- (b) The smoke barriers shall consist of non-combustible partitions containing smoke check doors. The smoke barriers, including the enclosing walls to the corridor, shall be constructed to full height, carried right up to form a close joint with the soffit of the floor slab above, or an imperforate non-combustible ceiling or the roof coverings;
- (c) the smoke barriers shall be sited at suitable locations across the corridor to create multiple sections, with each having free and direct access to an exit or exit staircase, exit passageway or exit ramp.
- (d) smoke-check doors excluding glass doors, shall be provided with clear glass vision panels having at least 25% of the surface area of each door leaf;
- (e) smoke-check doors shall be self-closing, swinging type and may be double-swing but shall close the opening completely with only such clearance as is reasonably necessary for proper operation. The doors shall be closely fitted around their edges and the bottom clearance gap between such doors and the floor shall not exceed 4mm;
- (f) smoke-check doors shall normally be in the closed position. However, they may be left open if they are arranged to close automatically by an approved electro-magnetic or electro-mechanical device which can be activated by the presence of smoke and/or the building fire alarm system.

EXPLANATIONS & ILLUSTRATIONS

2.7.4

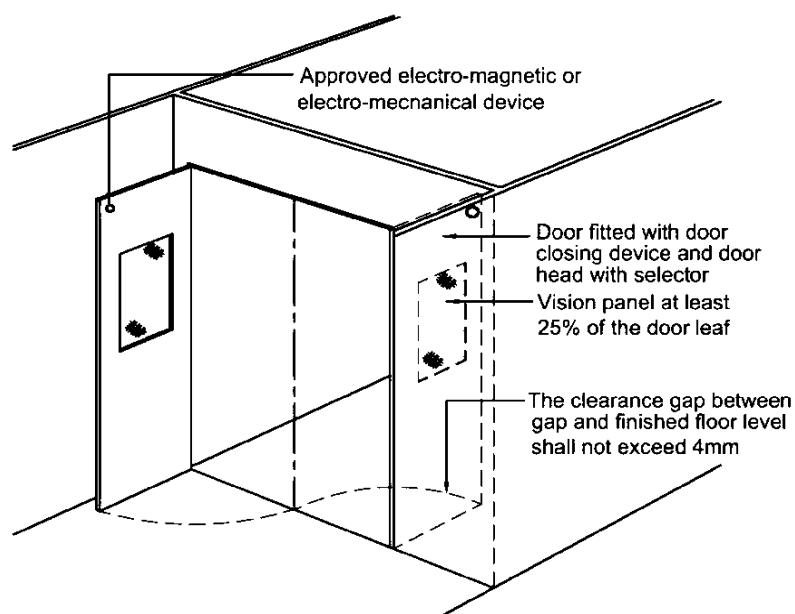

Diagram 2.7.4-2

The above requirement applies to internal corridors in hotel floors, which are not naturally ventilated. The smoke barriers shall consist of non-combustible partitions containing smoke check doors. The smoke barriers, including the enclosing walls to the corridor, shall be constructed of full height, carried right up to form a close joint with the soffit of the floor slab above, or an imperforate non-combustible ceiling or the roof coverings.

**EXPLANATIONS & ILLUSTRATIONS****2.7.4**

With long internal corridors being subdivided by smoke barriers and smoke check doors into multiple sections, there is no need to provide separate pressurisation system to each of the sub-divided sections.

The smoke barriers shall be situated at suitable locations across the corridor to create multiple sections, with each having free and direct access to an exit or exit staircase, exit passageway or exit ramps.

Smoke check door if it is not a glass doors, shall be provided with a clear glass panels having at least 25% of the surface area of the door leaf.

Smoke check doors shall be self-closing, the swinging type and may be double swinging but shall close the opening completely. The doors shall be closely fitted around their edge and the bottom clearance gap between door and finished floor level shall not exceed 4mm. The door is not required to have fire resistance rating.

Smoke check doors shall normally be in the closed position. However, they may be left open if they are arranged to close automatically by an approved electro-magnetic or electro-mechanical device which can be activated by the presence of smoke and/or the building fire alarm system.



CHAPTER 2

2.8 ASSEMBLY OCCUPANCY

2.8.1 General

Assembly Occupancy include all buildings or portions of buildings used for gathering together of more than 50 persons for such purpose as deliberation, worship, entertainment, eating, drinking, amusement or awaiting transportation.

Assembly Occupancies include but are not limited to :

Performance Theatres, Cinemas, Assembly Halls, Auditoriums, Exhibition Halls, Museums, Skating Rinks, Gymnasiums, Bowling Establishments, Pool Rooms, Armouries, Mortuary Chapels, Libraries, Restaurants, Nightclubs, Discotheques, Churches, Dance Halls, Club Rooms, Passenger Stations and Terminals of Public Transportation Facilities, Courtrooms, Conference Rooms and Drinking Establishments.

EXPLANATIONS & ILLUSTRATIONS

No illustration.

Not all buildings or portions of buildings used for assembly occupancy of more than 50 persons are considered as public building. Clause 1.2.49 of the Fire Code defines “public building” as those buildings or part thereof used or constructed or adapted to be used as a shop, office, hospital or place of public resort, not being a church, chapel, mosque, temple or other place where public worship is or religious ceremonies are performed. See clause 1.2.49 for further explanation on “public building”.

Assembly occupancy could be found in other purpose groups other than places of public resort, for example auditorium in office building, lecture theatre in school/institution, etc.



CHAPTER 2

2.8 ASSEMBLY OCCUPANCY

2.8.2 Number and width of exit facilities

Number and minimum width of exits for assembly occupancies shall comply with the provisions tabulated as follows:

No. of Occupants	Min. no. of Doors	Min. width of Corridors
51 - 200	2	1000 mm
201 - 500	2	1250 mm
501 – 1000	3	1250 mm
Exceeding 1000	4	1250 mm

EXPLANATIONS & ILLUSTRATIONS

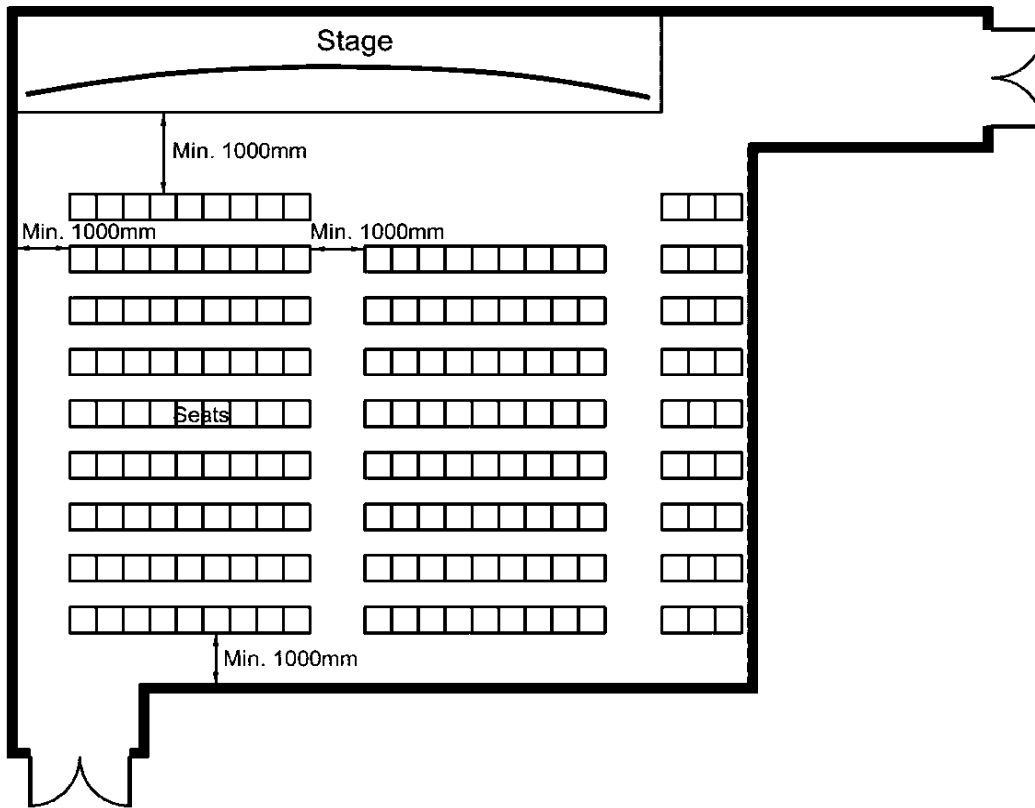

Diagram 2.8.2

The total number of occupant load of the above auditorium is more than 50 persons, but not exceeding 200 persons. The clear width of each exit door shall be sufficient to receive at least half the occupant of the floor space. The clear width of the aisles or gangways shall not be less than 1000mm. The exit doors shall be sited remote from each other to comply with cl.1.2.60.



CHAPTER 2

2.8 ASSEMBLY OCCUPANCY

2.8.3 Aisles and gangways

Assembly Occupancy with Fixed Seating: (Performance theatres, Cinemas, Auditoriums, Concert Halls etc)

Aisles and Gangways

- (a) clear aisles or gangways of not less than the minimum width of corridors shall be provided around the auditorium, stalls and balconies leading to doors or exit doors, and
- (b) aisles or gangways shall be provided with intersecting rows of seating and the number of seats in a row shall be in accordance with the provisions tabulated as follows:

Seat way width (mm)	Maximum No of seats in a row	
	Gangway on one side	Gangway on two sides
300 to 324	7	14
325 to 349	8	16
350 to 374	9	18
375 to 399	10	20
400 to 420	11	22
425 to 449	12	24
450 to 474		26
475 to 499		28
500 or more		Limited by the travel distance

Table 2.8.3(a)(ii) Number of seats in a row

The seat way shall be the minimum clear width between rows, which shall not be less than 300mm, measured as the clear horizontal distance from the back of the row ahead (including seats that tip up automatically) and the nearest projection of the row behind when the seats are in upright position. The seat way widths shall be constant throughout the length of the row. (See diagrams 2.8.3(a)(ii) - A and B).

EXPLANATIONS & ILLUSTRATIONS

2.8.3

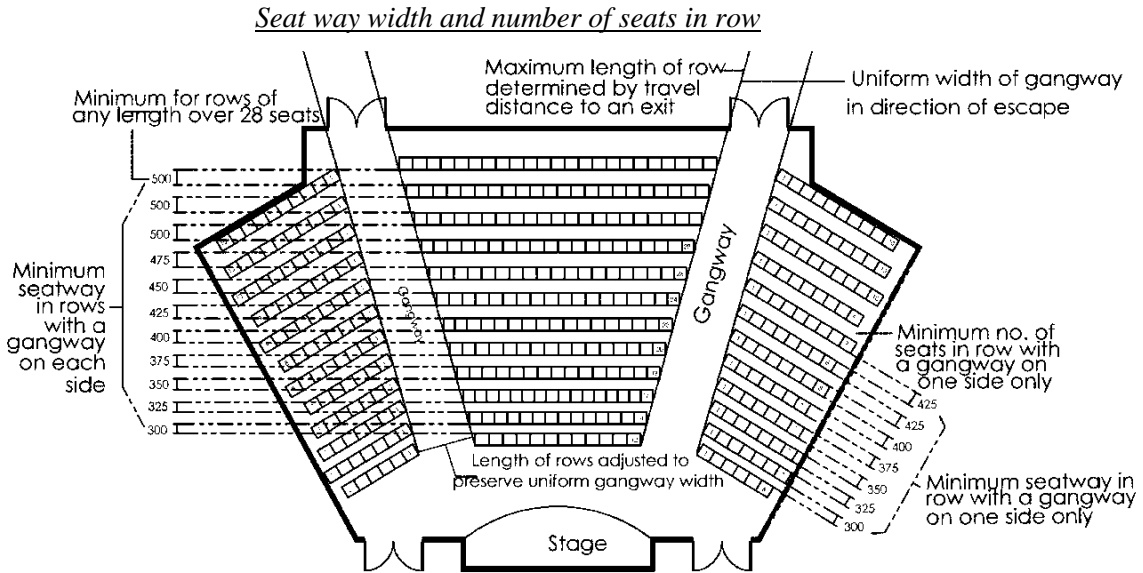

Diagram 2.8.3(a)-1

The above diagram illustrates uniform width of gangway in the direction of escape, where escapes in opposite directions are available in the auditorium.

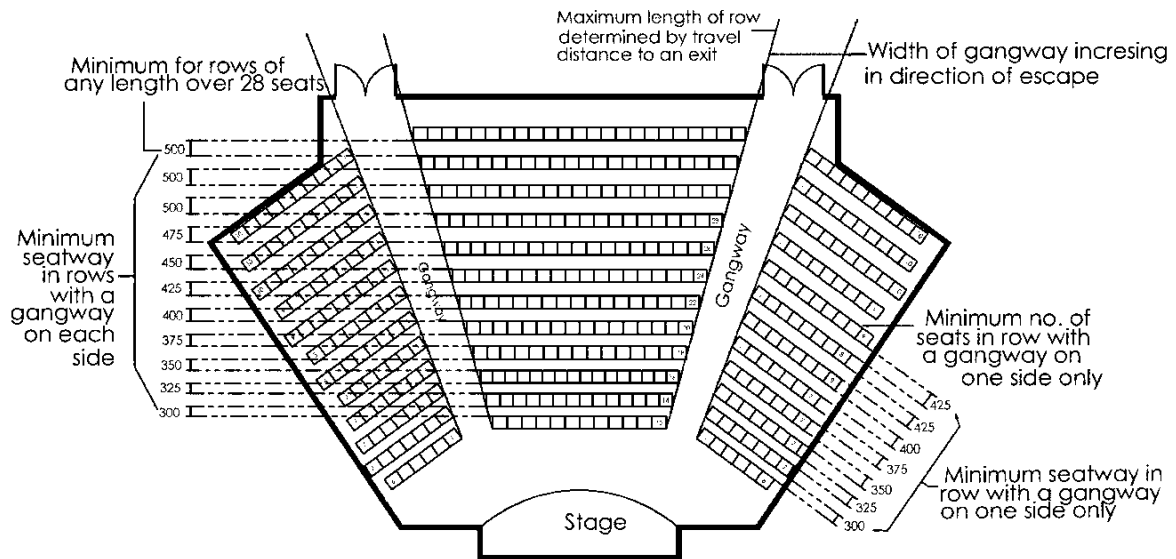

Diagram 2.8.3(a)-2

Prior consultation with MFRS is required if any row has more than 30 seats, as there could be concern on congestion along the gangways and at the exits.

The seating materials, in all cinemas, theatres, concert halls, auditorium, etc are required to be type tested by a recognised testing laboratory and shall be listed by a recognized certification body.



EXPLANATIONS & ILLUSTRATIONS	2.8.3(a)
---	-----------------

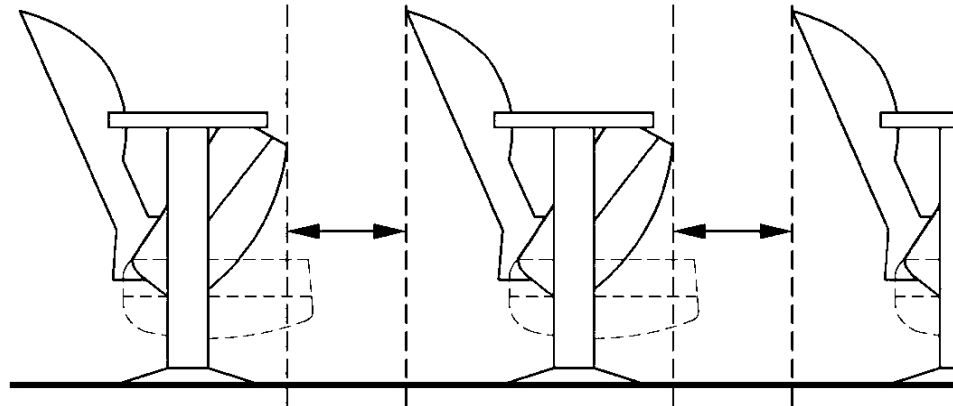

Diagram 2.8.3(a)-3

Determination of seat way width

Seat way width shall not be less than the tabulated seat way width in Table 2.8.3(a) and shall be constant throughout the length of the row.

Measurement of width of aisle access way formed by rows of chairs.

Access and egress routes shall be maintained to facilitate easy movement towards the gangway(s) thus allowing faster evacuation of occupants.



(c) for changes of level, steps shall not be used to overcome differences in level in aisles or gangways unless the slope of such gangways exceeds 1 in 10, and

EXPLANATIONS & ILLUSTRATIONS

2.8.3

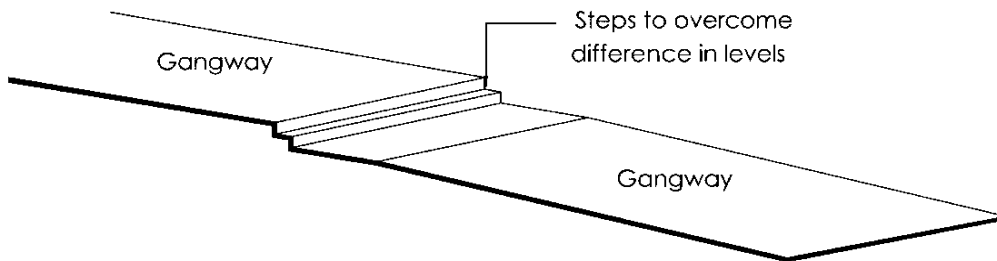

Diagram 2.8.3(c)

Steps (min. 2 numbers) may be used when gradient of slope of gangways exceeds 1 in 10. The dimensions of treads and risers shall comply with cl.2.3.3(d0(iii)).

(d) handrails shall be provided, where steps of a pitch exceeding 30 degrees or ramps of a slope exceeding 1 in 10 are provided in aisles or gangways flanking the seating, and

EXPLANATIONS & ILLUSTRATIONS

2.8.3

Handrail required with slope exceeding 1:10

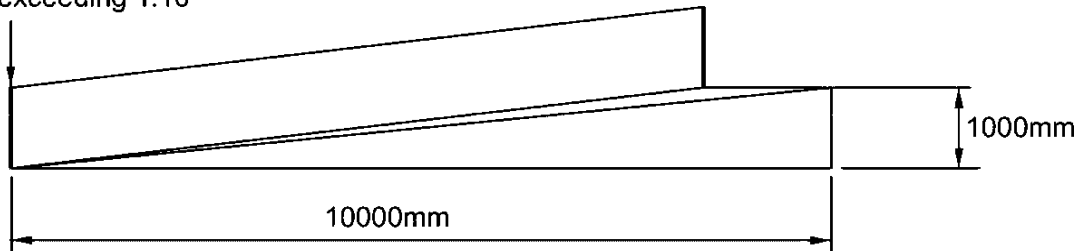

Diagram 2.8.3(d)-1

Handrail required when pitch exceed 30°

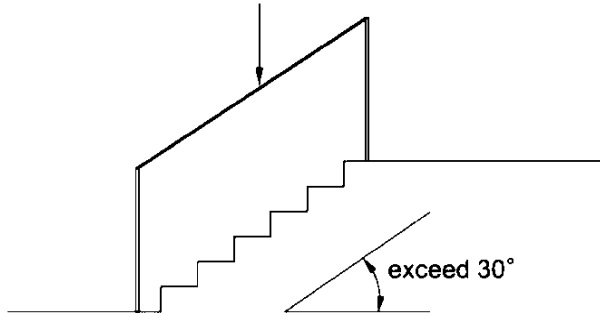

Diagram 2.8.3(d)-2



- (e) flooring for the surface of steps and ramps forming the aisles or gangways shall be finished using non-slip materials, and
- (f) illumination of steps shall be such that each step is clearly visible in the event of emergency.
- (g) Seats for cinemas, theatre, auditorium, etc

The construction of combustible upholstered seats in cinema, theatre, auditorium, etc shall comply with BS5852 in respect of the following testing standard:

- (i) Smouldering Ignition Source;
- (ii) Flaming Ignition Source 1; and
- (iii) Crib Ignition Source 5.

EXPLANATIONS & ILLUSTRATIONS

2.8.3

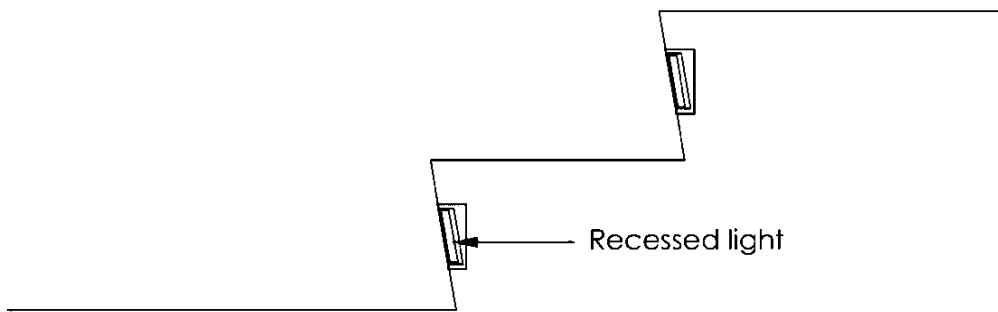

Diagram 2.8.3(f)

The rationale of illuminating the steps is intended to alert the public of the presence of steps. Such arrangement will help to prevent tripping. Where the emergency lighting of the hall or auditorium is able to provide sufficient lighting to the steps, separate emergency power supply to illuminate the steps would not be required.



CHAPTER 2

2.8 ASSEMBLY OCCUPANCY

2.8.4 Exits from a theatre, cinema or a concert hall

- (a) The number and capacity of exits from an enclosed space in an assembly occupancy used or intended for use as cinema, concert hall, auditorium, performance theatre that is not normally provided with natural ventilation and lighting, shall be provided its own means of escape without having to take into account exits provided for its adjoining parts of the same building in which it is housed. Exception may be permitted where the occupancy load does not exceed 200 persons, in which case at least half the capacity of exits must be provided within the compartment.
- (b) Where a building or part of a building is designed as a cineplex to house multiple mini-cinemas, the means of escape to be provided may be shared by all the mini-cinemas. Each cineplex shall be treated as a single big cinema for the purpose of determining the exit requirements under sub-clause 2.8.4.
- (c) The exits adjacent or attached to cinema, theatre or concert hall and the like can be shared as exits with the other parts of the building, provided the exits are accessible from the common circulation areas. The occupancy load of the cinema, theatre, concert hall and the like does not exceed 200 persons.

EXPLANATIONS & ILLUSTRATIONS

2.8.4

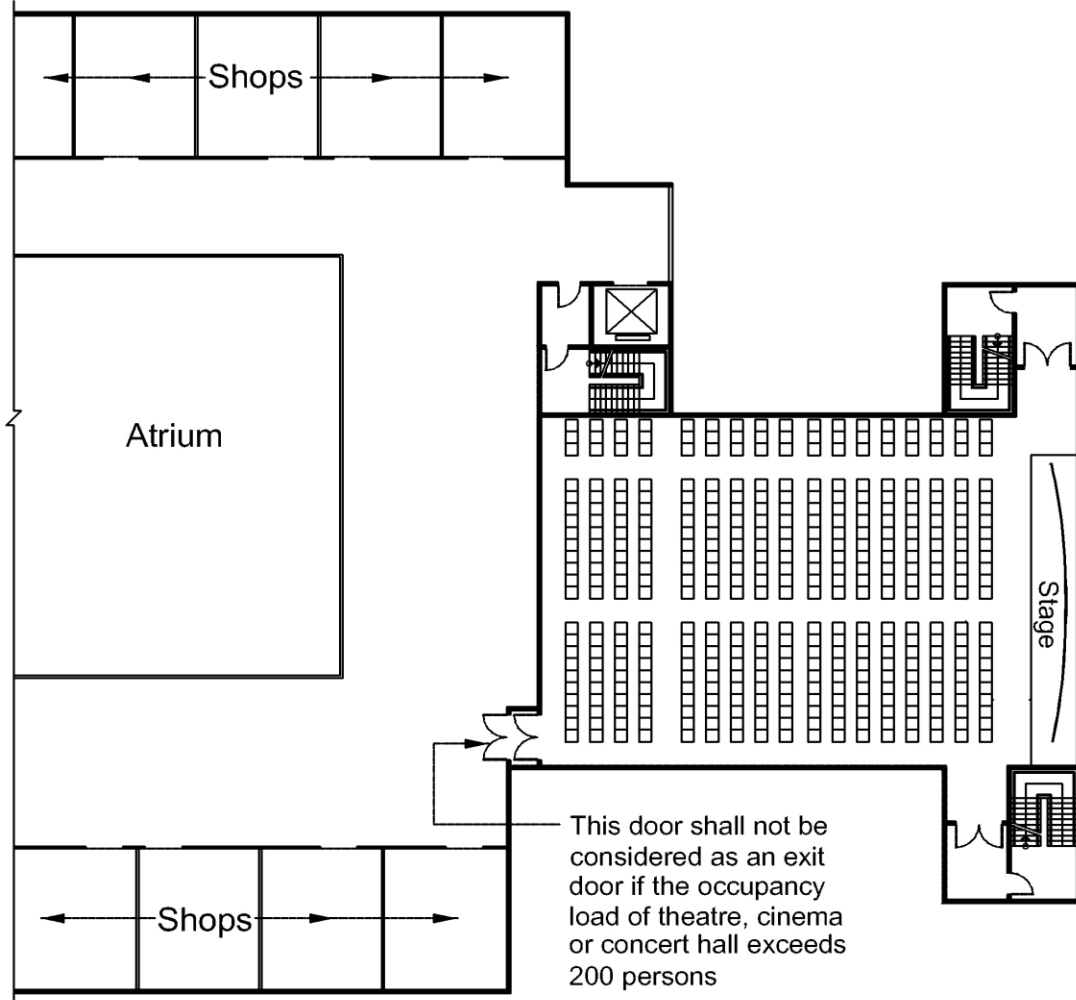

Diagram 2.8.4

A theatre, cinema or concert hall is considered a compartment by itself. It should be self sufficient in the provision of the exits for the occupants. Sharing of exit facilities with other part of the building under different occupancy is not permitted unless the occupant load of the theatre, cinema or concert hall is less than 200 persons.



CHAPTER 2

2.9 WORKERS' DORMITORIES

2.9.1 Dormitories

Dormitories include buildings or spaces in buildings where group sleeping accommodation is provided for workers under joint occupancy and single management, with or without meals, but without individual cooking facilities. The phrase "without individual cooking facilities" refers to the absence of cooking equipment in any room or unit of a dormitory.

EXPLANATIONS & ILLUSTRATIONS

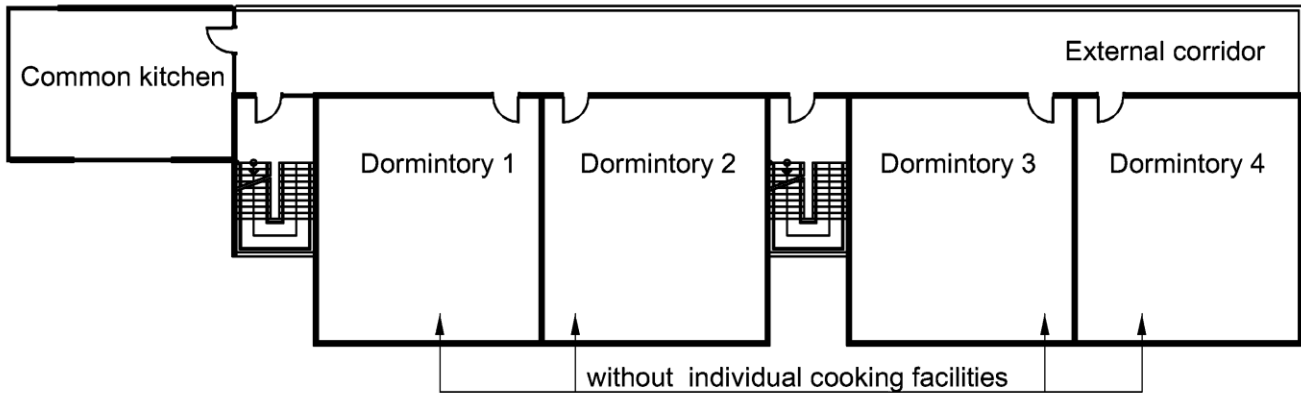

Diagram 2.9.1

Owing to different uses and risks, cooking shall not be allowed in the dormitory, which is meant for resting and sleeping. All cooking activities shall be carried out in the kitchen. This will eliminate the risk of fire occurring in any dormitory arising from cooking activities.



CHAPTER 2

2.9 WORKERS' DORMITORIES

2.9.2

(a) Size

Each dormitory bedroom shall not exceed 120m² and occupant load of 40 persons

(b) Occupant load

The occupant load shall be based on gross floor area on the basis of 3m² per person.

(c) No. of exit staircases or exit per storey

There shall be at least two independent exit staircases or other exits from every storey of a building.

(d) Maximum travel distance

The travel distance, measured from the most remote point of the dormitory bedroom to the nearest exit staircase or other storey exit, shall not exceed the maximum travel distance permitted under Table 2.2A.

EXPLANATIONS & ILLUSTRATIONS

The number of exits from individual rooms shall be as shown below:

One Exit door Situation

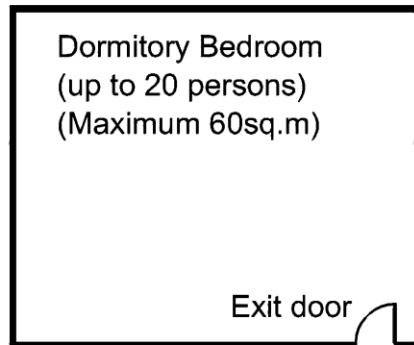

Two Exit doors Situation

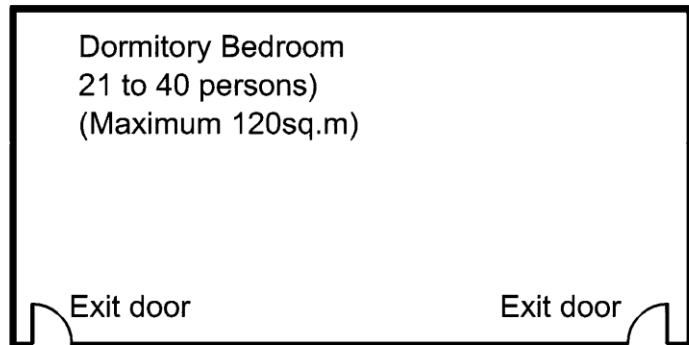

Diagram 2.9.2(c) & (d)



EXPLANATIONS & ILLUSTRATIONS

2.9.2

The maximum travel distance measured from the most remote point of a bedroom of a worker's dormitory to the nearest exit staircase, in accordance to Table 2.2A of the Fire Code, shall not exceed:

<i>Situation</i>	<i>Distance (m)</i>	
	<i>Unsprinklered</i>	<i>Sprinklered</i>
<i>One-way escape</i>	15	20
<i>Two- way escape</i>	30	60



CHAPTER 2

2.9 WORKERS' DORMITORIES

2.9.3 Internal corridor to dormitory bedrooms

Dormitory bedrooms with access through an internal corridor shall comply with the requirements as follows:

- (a) Dormitory bedrooms shall be separated from the internal corridor by a wall having fire resistance of at least 1-hour; and
- (b) Doors opening into internal corridors shall have fire resistance of at least half an hour and fitted with automatic self-closing device to comply with the requirements of cl.3.9.2, and

EXPLANATIONS & ILLUSTRATIONS

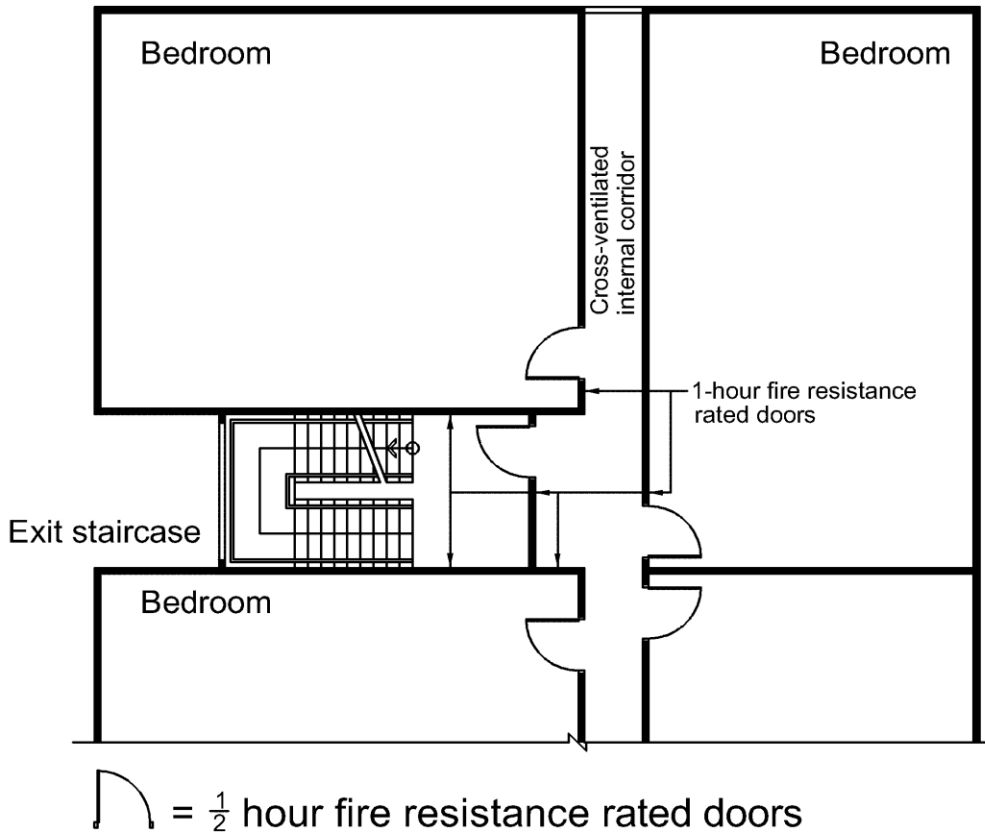

Diagram 2.9.3(a) & (b)

- (c) Internal corridors shall be naturally ventilated with fixed openings in an external wall, such ventilation openings being not less than 15 percent of the floor area of the internal corridor, and
- (d) The ventilation openings in the external walls shall not be less than 3.5 m² and shall be unobstructed from parapet wall or balustrade level upwards and be positioned on opposite sides of the corridor such that they provide effective cross-ventilation throughout the entire space of the corridor, and
- (e) The ventilation openings in the external walls shall not be more than 12m from any part of the corridor, and
- (f) Pressurisation of internal corridors in lieu of natural ventilation is not permitted, and

EXPLANATIONS & ILLUSTRATIONS

2.9.3

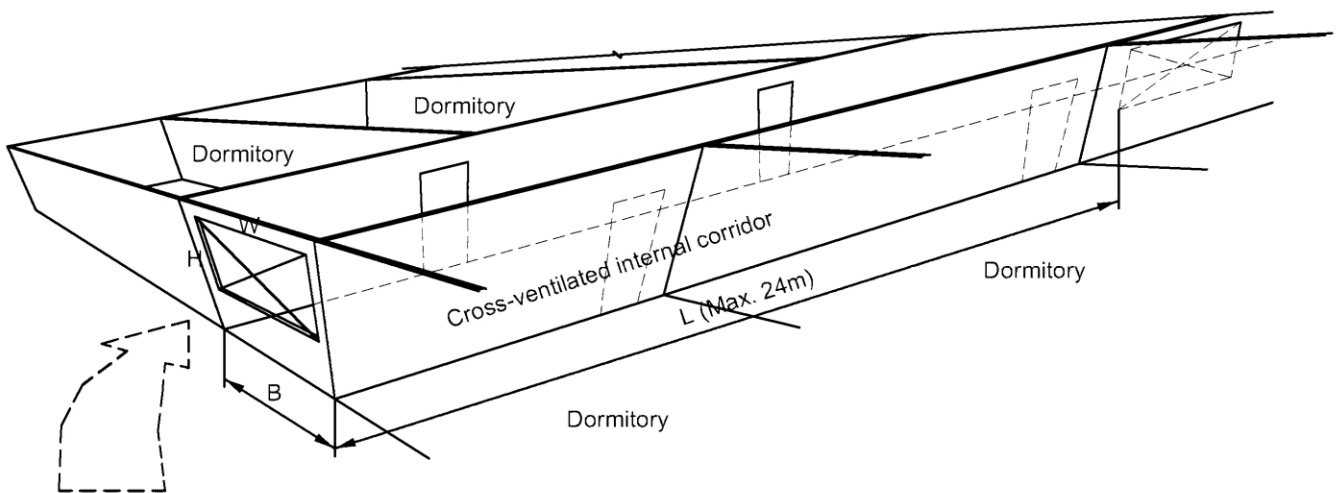

Diagram 2.9.3(c)

Area of each external opening = $W \times H$
 = min. 3.5m²

Area of external opening = $2(W \times H)$

Percentage of external openings Over internal corridor = $\frac{2(W \times H)}{L \times B} \times 100 = \text{Min. } 15\%$

Internal corridor shall either be cross-ventilated as illustrated above or provided with natural ventilation as illustrated in diagram 2.9.3(d) – 1. Pressurisation of internal corridor is not allowed.

EXPLANATIONS & ILLUSTRATIONS

2.9.3(d)

Ventilation of internal corridors to worker's dormitory

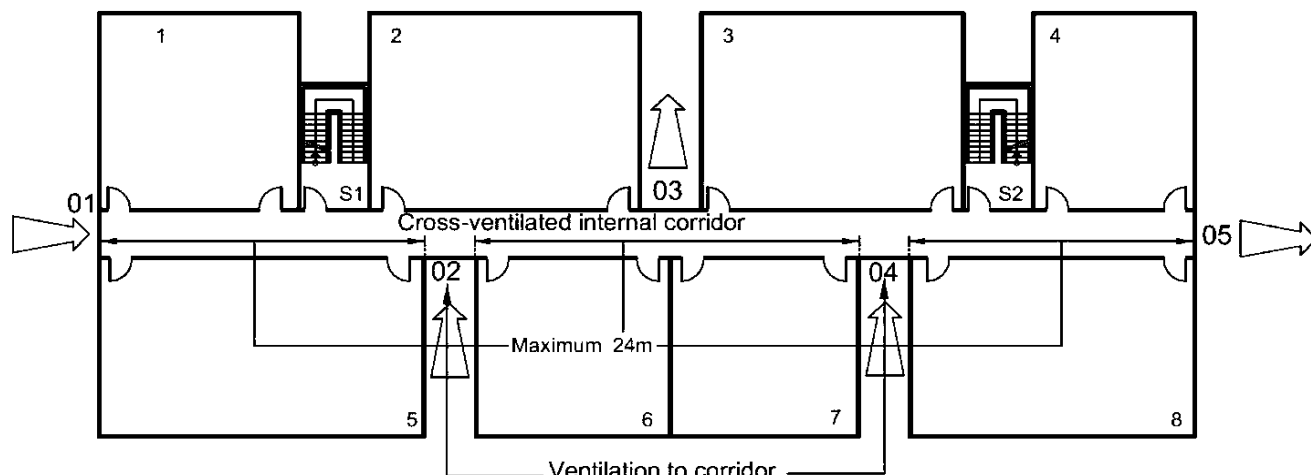

S1, S2 = Exit Staircase

01 - 05 = Openings to internal corridor for natural ventilation

Diagram 2.9.3(d)-1

Ventilation breaks (02, 03 & 04) as illustrated above are provided to cross-ventilate the internal corridor.

Sectional elevation showing naturally ventilated internal corridor

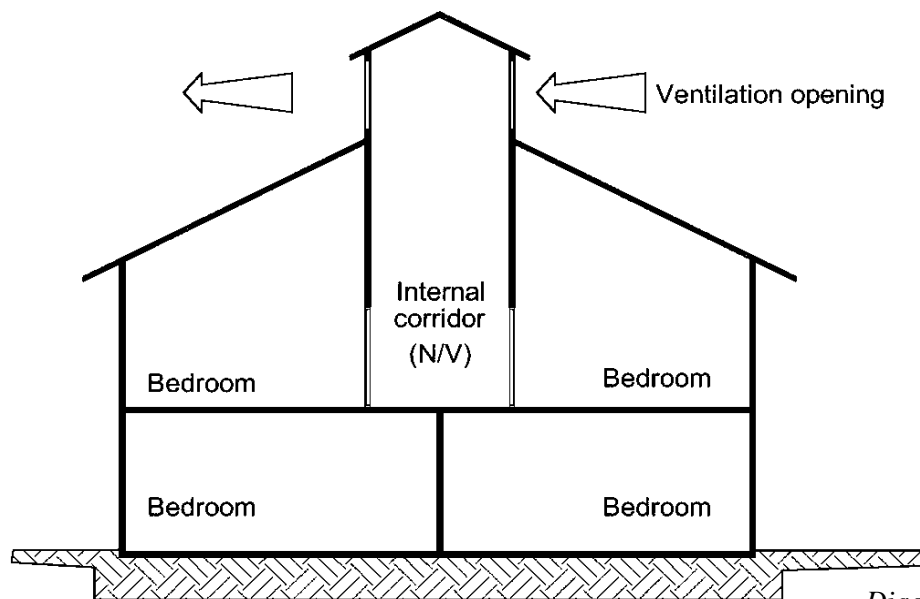

Diagram 2.9.3(d)-2

Ventilation openings provided throughout the sides of the jack roof would be able to provide sufficient natural ventilation throughout the internal corridor.

(g) Other rooms or spaces which open into or form part of the bedroom corridor and which may prejudice the means of escape provision shall be required to be compartmented by 1-hour fire rated enclosures and 1/2-hour fire doors

EXPLANATIONS & ILLUSTRATIONS

2.9.3

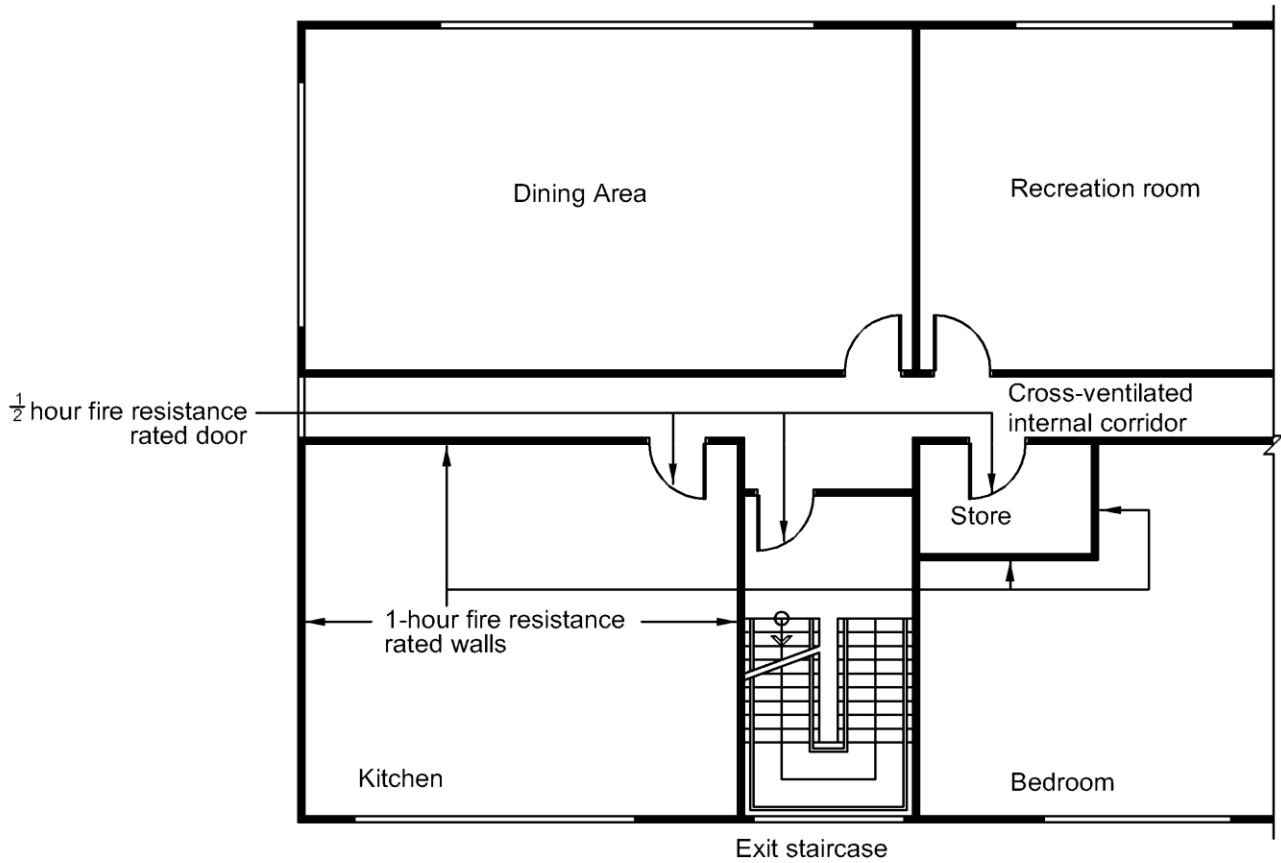

Diagram 2.9.3(g)

Store shall be fire compartmented as it opens into the designated internal escape corridor.



CHAPTER 2

2.9 WORKERS' DORMITORIES

2.9.4 External corridor

Dormitory bedrooms with access through an external corridor shall comply with the requirements as follows:

- (a) Dormitory bedrooms shall be separated from the external corridor by a wall having fire resistance of at least 1 hour, except that ventilation openings of non-combustible construction may be fixed at or above a level of 1.1m, measured from the finished floor level of the external corridor to the sill height of the opening, and
- (b) Doors opening into the external corridor shall not be required to have fire resistance rating, and

EXPLANATIONS & ILLUSTRATIONS

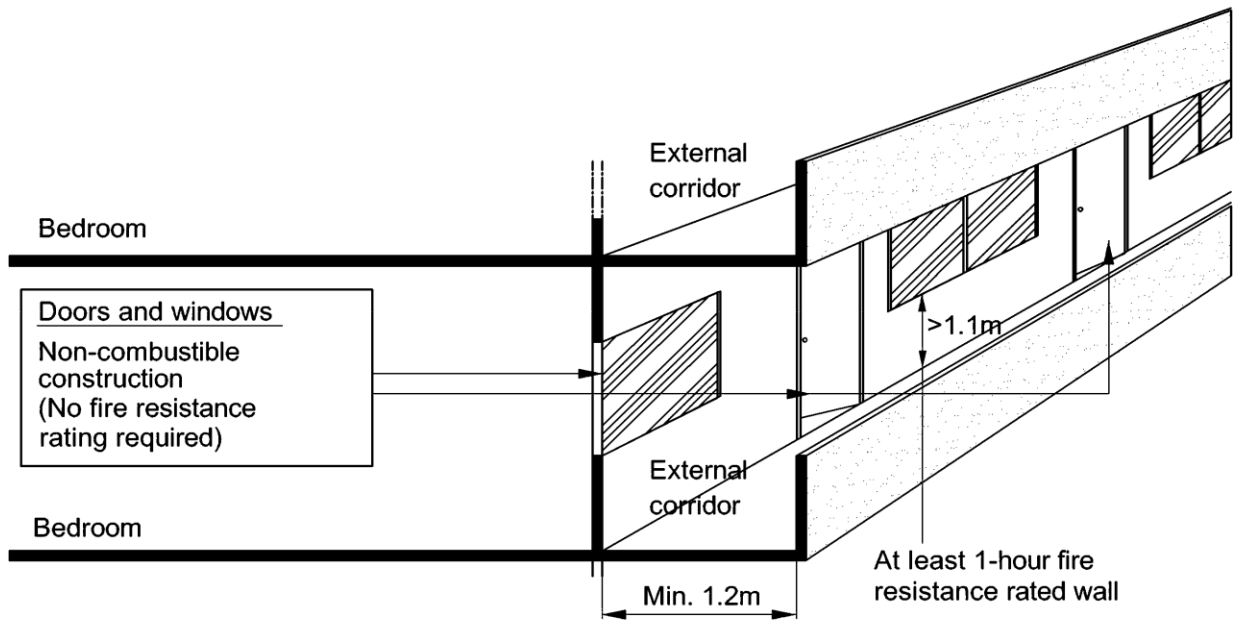

Diagram 2.9.4



(c) External corridors shall conform to the requirements of external exit passageway for minimum width, changes in floor level, roof protection and enclosure on the open side.

EXPLANATIONS & ILLUSTRATIONS

2.9.4

No illustration.

Please see explanatory notes to Cl.1.2.30 and Cl. 2.2.13(a)



CHAPTER 2

2.9 WORKERS' DORMITORIES

2.9.5 Smoke free approach to exit staircase

Entry into an exit staircase from any part of a building of more than 4 storeys above ground level shall comply with requirements of Cl.2.2.13 - requirements of smoke free approach to exit staircase. Pressurisation of staircase in lieu of the provision of smoke-stop lobby is not permitted.

EXPLANATIONS & ILLUSTRATIONS

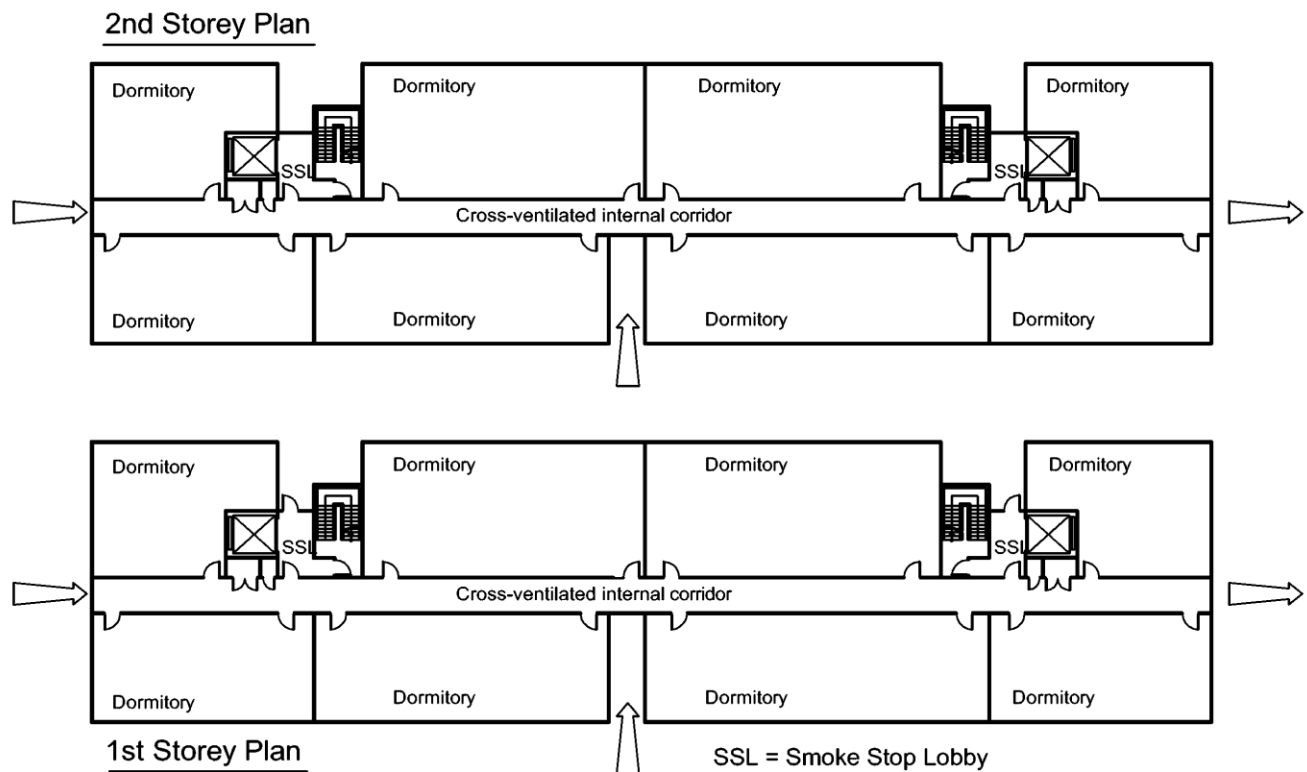

Diagram 2.9.5

See Cl.2.2.13 for further illustration. Under Clause 2.2.13(c)(i), exit staircases to buildings under Purpose Group III will not be allowed to omit the smoke-stop lobby.



CHAPTER 2

2.10 EXIT LIGHTING & DIRECTIONAL SIGN

2.10.1 Exit lighting

Exits of all buildings, except for those belonging to Purpose Group I, shall be provided with artificial lighting facilities to the satisfaction of the requirements in Chapter 8.

EXPLANATIONS & ILLUSTRATIONS

No illustration.

Exit lighting shall be provided in all escape routes, such as staircases, corridors in such manner that residents shall not have to traverse unlit or dark spaces when escaping from the door of their unit to the safe exterior space at ground level. The purpose of this provision is to ensure that the escape routes are visible to the evacuating occupants at all times.



CHAPTER 2

2.10 EXIT LIGHTING & DIRECTIONAL SIGN

2.10.2 Exit and directional sign

In all buildings or parts of building other than those belonging to Purpose Groups I and II (residential floors only), the location of every exit on every floor shall be clearly indicated by exit sign and directional signs to comply with the requirements in Chapter 8.

EXPLANATIONS & ILLUSTRATIONS

No illustration.

Exit and exit directional signs are required to be provided to the common areas and escape routes of residential buildings belonging to Purpose Group II. Details of provisions will be covered in Chapter 8.



CHAPTER 2

2.10 EXIT LIGHTING & DIRECTIONAL SIGN

2.10.3 Photo luminescent marking

In all buildings, except Purpose Groups I & II, photo luminescent marking/tape to guide occupants along evacuation routes to appropriate exit shall be provided:

- (a) along internal walls and/or floors of the exit staircase, smoke-stop lobby and fire-fighting lobby;
- (b) on the doors of smoke-stop lobby, fire-fighting lobby and exit staircase;
- (c) along corridor with exit directional signs.

Omission of photo luminescent marking/tape is permitted on the following conditions:

- (i) the emergency power supply of the exit lightings, exit signs and directional signs in the above locations shall be self-contained battery pack (single point system) in compliance with BS 5266 or central battery supply backed up by stand-by generator;
- (ii) there shall be at least 2 emergency luminaires in the smoke-stop lobby, fire-fighting lobby and corridor with exit directional signs, such that no part of such spaces shall be left in total darkness should there be failure of anyone of the emergency luminaires; and
- (iii) there shall be at least one emergency luminaire at every exit staircase landing.

Note: Single point (emergency lighting) system - A system of emergency lighting employing self-contained emergency luminaires.

EXPLANATIONS & ILLUSTRATIONS

At the protected lobby door and exit staircase

Photo luminescent exit sign with the word "EXIT" or exit legend  as per BS ISO 3864-1 with green background printed on the surface or silk screened on reverse surface, on the protected lobby door and exit staircase door.

The door affixed tape or marking shall be at least 300mm long and 150mm wide and be placed not less than 150mm or more than 400mm from bottom sill of the exit staircase door. The photo luminescent exit sign is provided in addition to the electrical exit sign mounted above the doorway.



EXPLANATIONS & ILLUSTRATIONS

2.10.3

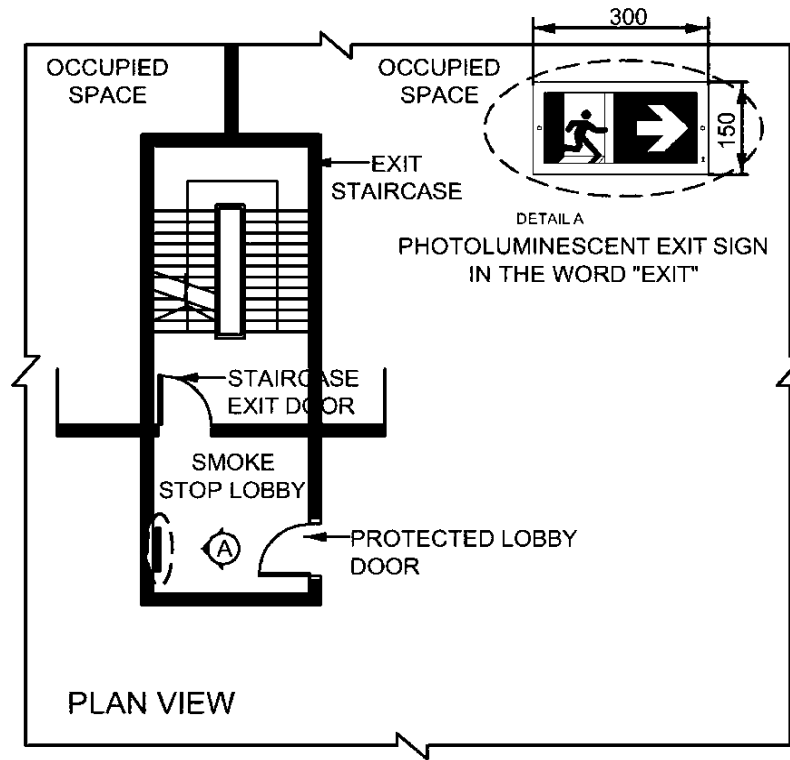

Diagram 2.10.3-1

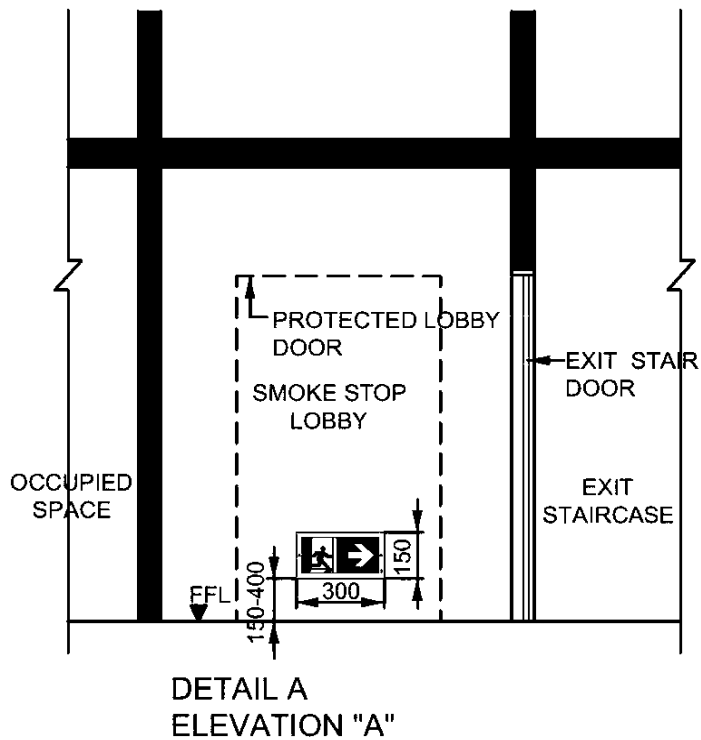

Diagram 2.10.3-2

CHAPTER 2

2.10 EXIT LIGHTING & DIRECTIONAL SIGN

2.10.4

The width of photo luminescent marking or tape shall be at least 50mm and be placed at low level. The bottom of the low level sign shall not be less than 150mm or more than 400mm above the floor level.

EXPLANATIONS & ILLUSTRATIONS

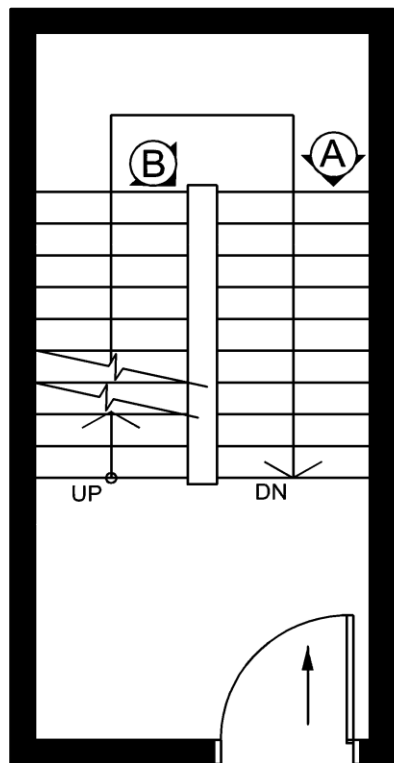

TYPICAL FLOOR
PLAN VIEW

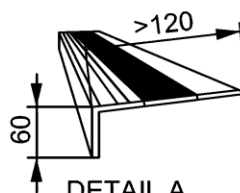

DETAIL A

PHOTOLUMINESCENT NOSING STRIP
TO STAIRCASE

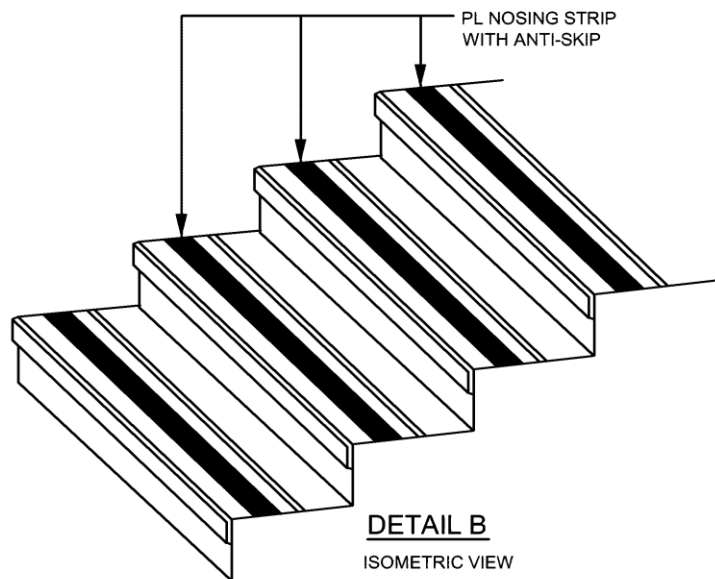

DETAIL B

ISOMETRIC VIEW

Diagram 2.10.4-1

Photo luminescent nose strip at the leading edge of stair riser.

The strip shall be at least 50mm in width and to be placed at the leading edge of each stair rise.



EXPLANATIONS & ILLUSTRATIONS

2.10.4

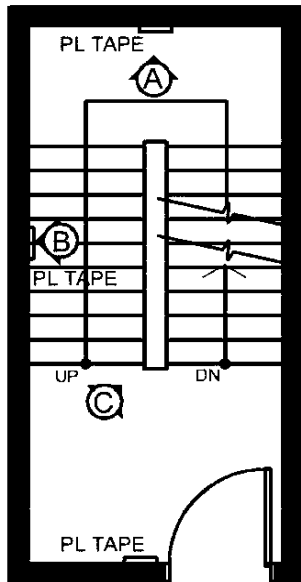

TYPICAL FLOOR PLAN VIEW

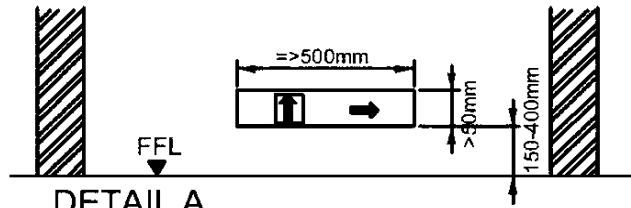

DETAIL A
PL TAPE WITH DIRECTIONAL ARROW & EXIT LEGEND ON STAIRCASE LANDING WALL

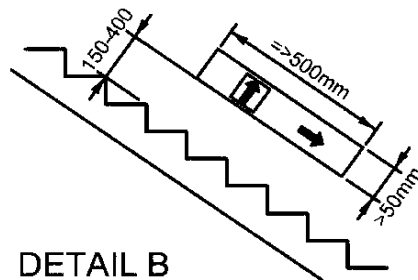

DETAIL B
PL TAPE WITH DIRECTIONAL ARROW & EXIT LEGEND ALIGN WITH SLOPING WALL

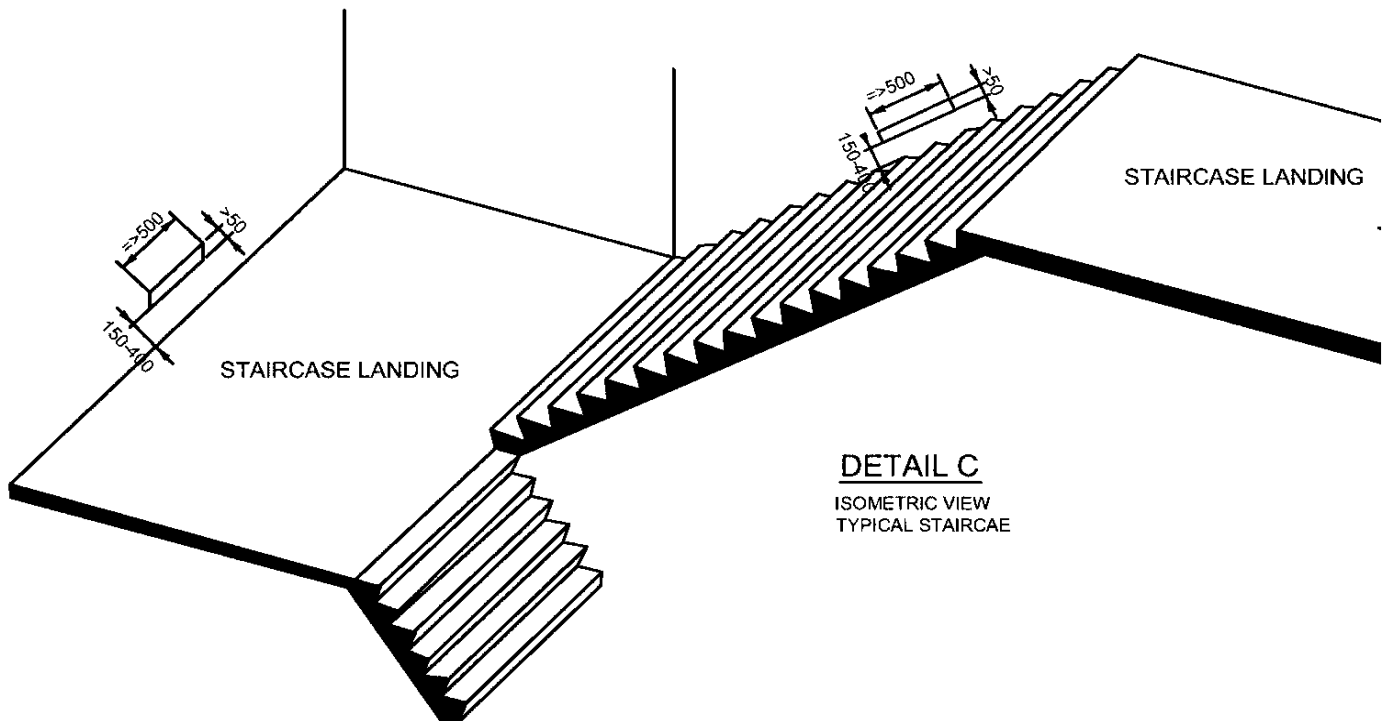

DETAIL C
ISOMETRIC VIEW
TYPICAL STAIRCAE

Diagram 2.10.4-2



EXPLANATIONS & ILLUSTRATIONS

2.10.4

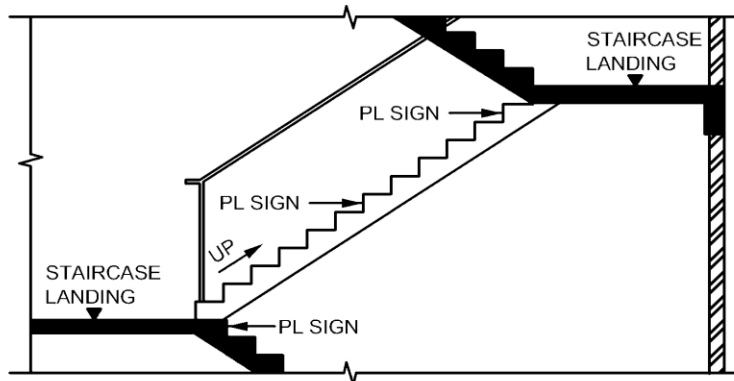

TYPICAL SECTION STAIRCASE FLIGHT IN BASEMENT

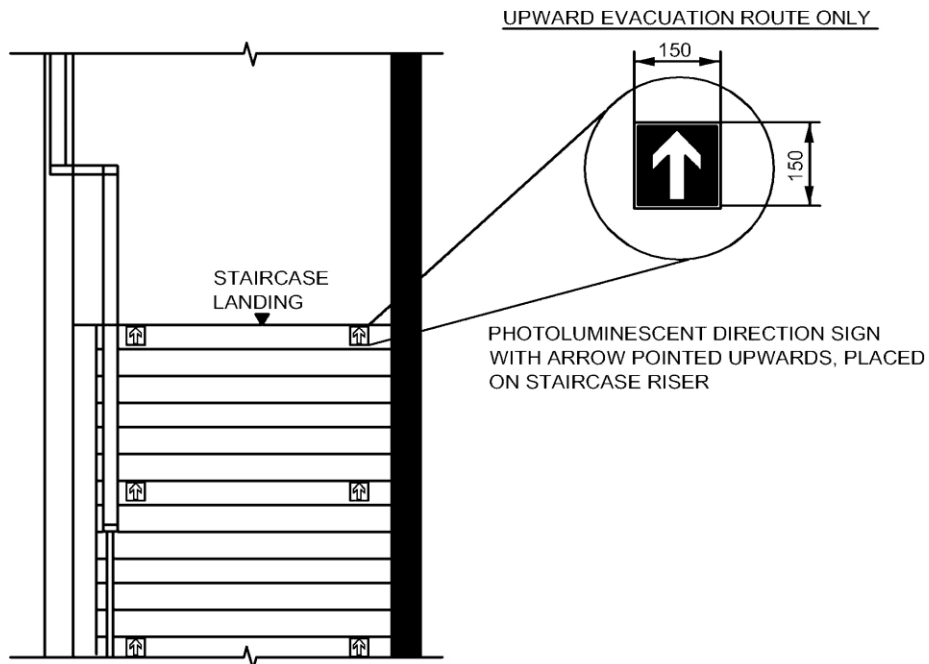

DETAIL A FRONT ELEVATION

Diagram 2.10.4-3

In designated corridor with exit directional sign.

Applicable to building with fixed corridor leading to exit staircase, except hotel guest room floor where low level electrical exit directional sign is mandatory.

EXPLANATIONS & ILLUSTRATIONS

2.10.4

Photo luminescent exit directional sign with the word "EXIT" or Exit legend  as per BS ISO 3864-1 and directional arrow with green ground printed on the surface or silk screened on reverse surface, along one side of the walls of the designated corridor. For long corridor, the Photo luminescent exit directional sign shall be affixed at not more than 10m interval. Additional sign would be required at junctions.

The wall affixed sign shall be at least 300mm long and 150mm wide and be placed not less than 150mm or more than 400mm from the lobby landing level. Depending on the length and configuration of the designated corridor, numerous number of signs to be provided on one side of the walls with directional arrow pointing towards the exit direction within designated corridor.

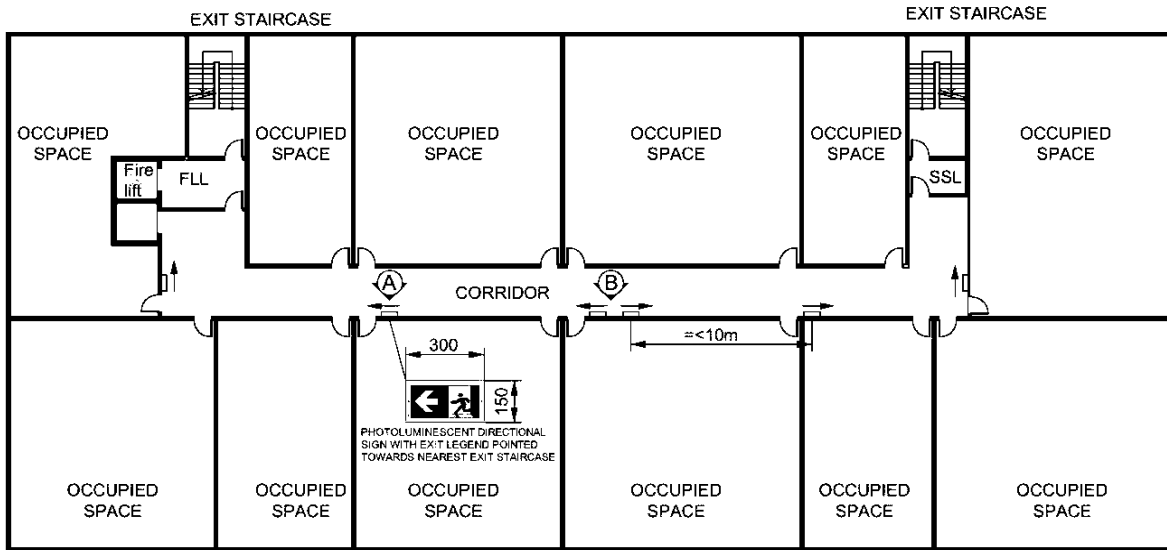

PLAN VIEW: PL SIGNS FOR INTERNAL CORRIDOR

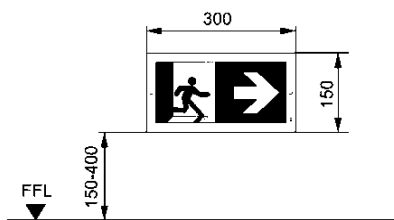

DETAIL A

PL SIGN WITH UNI-DIRECTIONAL ARROW, SIGN TO BE POINTED TO THE DIRECTION OF THE NEAREST EXIT STAIRCASE

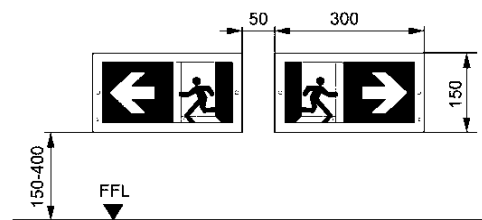

DETAIL B

PL SIGN WITH BI-DIRECTIONAL ARROWS, SIGN TO BE BETWEEN 2 EXIT STAIRCASE SUCH THAT TRAVEL DISTANCE TO EITHER STAIRCASE ARE EQUAL.

Diagram 2.10.4-4

**EXPLANATIONS & ILLUSTRATIONS****2.10.4****(1) Performance of Photoluminescent marking / tape**

The basic function of Photo luminescent marking / tape is to provide some luminance lighting at low level to aid evacuation of occupants under total power failure condition or low ambient lighting condition. Photo luminescent marking / tape shall be made of pigments that will absorb electrical or day lighting under normal ambient condition and emit light automatically in invisible wavelength and glow brightly upon immediate depletion of light source.

As a guide, the Photo luminescent marking / tape should deliver a luminance level at least 800 mcd/m² at 1 min. after removal of light source and at least 80 mcd/m² at 10 min. thereafter. The Photo luminescent marking / tape would remain visible after 6 hour at the luminance level of at least 1 mcd/m².

(2) Substrate of Photo luminescent marking / tape

For tape, direct printing of directional arrow in green on surface of vinyl or decal sticker with full photo luminescent background. For marking, direct printing of directional arrow, "EXIT" or exit legend. With green background on thin plastic or metal sheet or silk printed with green background on reverse side of thin transparent Perspex sheet.

For Photo luminescent nose strip, it shall be made of materials of the non skid and able to resist abrasion and wear.

(3) Method of fixing

The marking / tape could be affixed by strong adhesive glue on dry and smooth surface.

(4) Product listing

Product listing requirement is not required at this point of time.

For building under Purpose Group III to VIII, where the emergency lighting and exit signs are not of the self-contained battery pack type, integral with the lighting and sign fittings, self luminescent marking or tapes shall be provided to both edges of the treads and handrails and/or walls of the exit staircase. The rationale of the provision would ensure escape facilities are always visible during an emergency situation.

The purpose is to provide illumination for escape path in the event of a total power failure i.e. failure of both self-contained battery pack system and standby generator provision in a building at the same time. Thus, the occupant groping in the dark is almost "impossible". Both the provision would complement each other and facilitate orderly evacuation process.