



CHAPTER 4

4.1 GENERAL

4.1.1 General

The purpose of this Chapter of the Code is to make provision for space around buildings to enable effective mounting of rescue and external fire fighting operations.

EXPLANATIONS & ILLUSTRATIONS

No illustration.

CHAPTER 4

4.2 PROVISION FOR EXTERNAL ACCESS TO BUILDING FOR FIRE FIGHTING AND ACCESSIBILITY OF SITE TO FIRE FIGHTING APPLIANCES

4.2.1 Introduction

Access way shall be provided for accessibility of site to fire fighting appliances. To permit fire fighting appliances to be deployed, the access way shall have a minimum width of 6m throughout its entire length. Access openings shall be provided along the external walls of buildings fronting the access way to provide access into the building for fire fighting and rescue operations.

Access way shall be provided to within 18m of breaching inlet for buildings that exceed the habitable height of 10m.

EXPLANATIONS & ILLUSTRATIONS

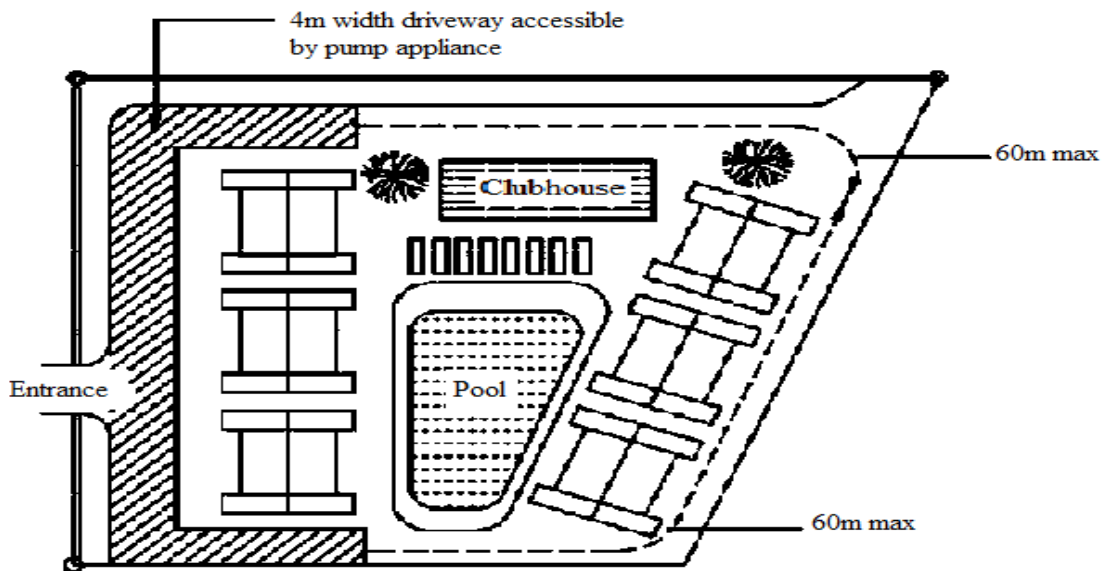

Diagram 4.2.1-1

For building exceeding 10m in habitable height under Purpose Group II, the breaching inlets shall be provided at the foot of the riser stack at ground level. The breaching inlets shall be within 18m direct sight from fire engine access road.



EXPLANATIONS & ILLUSTRATIONS

4.2.1

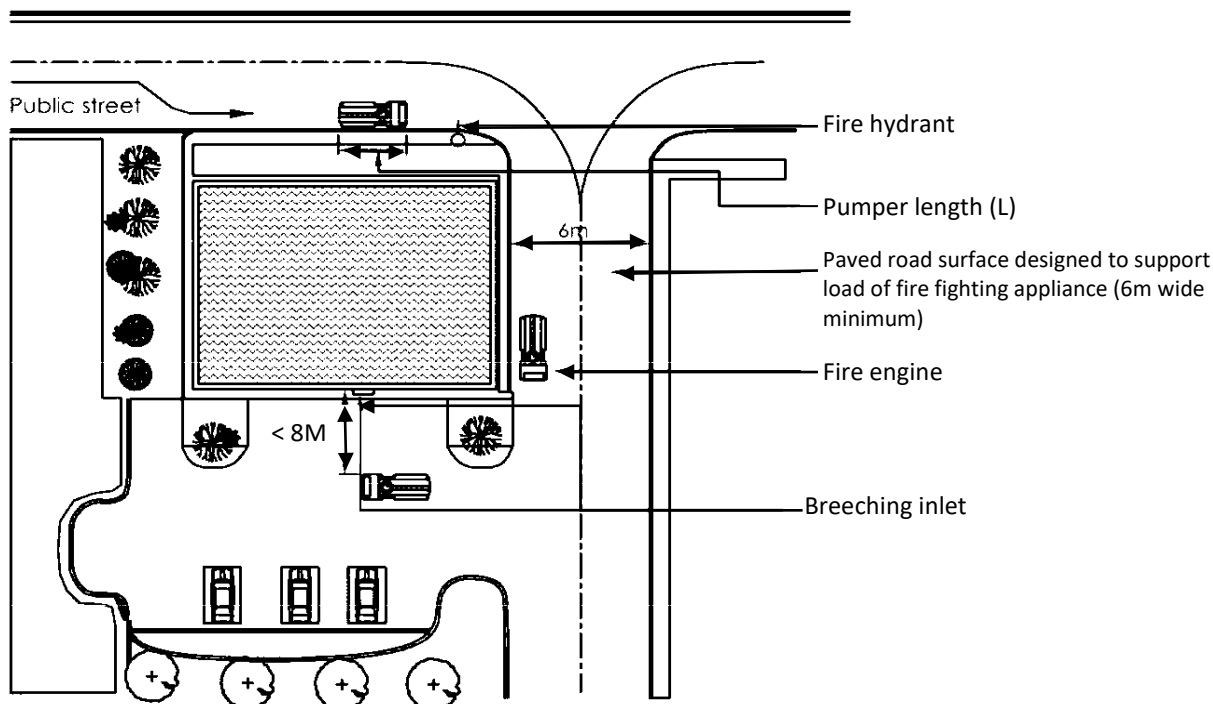

Diagram 4.2.1-2

All purpose groups excluding I & II shall be provided with accessibility for fire-fighting appliances. The internal driveways shall be constructed to have the required width and be able to withstand the operational loading of fire engine when conducting external fire fighting. Access openings along the external walls of the buildings facing the access way shall be provided for the purpose of conducting fire fighting and rescue operations.



CHAPTER 4

4.2 PROVISION FOR EXTERNAL ACCESS TO BUILDING FOR FIRE FIGHTING AND ACCESSIBILITY OF SITE TO FIRE FIGHTING APPLIANCES

4.2.2 ACCESSWAY FOR FIRE FIGHTING APPLIANCES

Provision of access way

- (a) (i) For buildings under Purpose Group I, access way will not be required, irrespective of the building height. However, in cluster housing developments, (Cluster housing is landed housing with shared communal facilities), fire engine access road with a minimum width of 4m shall be provided for access by pump appliance to within a travel distance of 60m from every point on the projected plan area of any building in the housing developments.
- (ii) For buildings under Purpose Group II, no access way will be required for buildings that do not exceed the habitable height of 10m. However, fire engine access road having minimum 4m width for access by pump appliance shall be provided to within a travel distance of 60m of every point on the projected plan area of the building.

This requirement for fire engine access road shall not apply to non-residential standalone building, such as clubhouse, car park, etc. (excluding guardhouse and substation) that are located within the housing development. The non-residential standalone building shall comply with Cl.4.2.2 (a) (iv) and Cl.4.2.2 (b) (i).

EXPLANATIONS & ILLUSTRATIONS

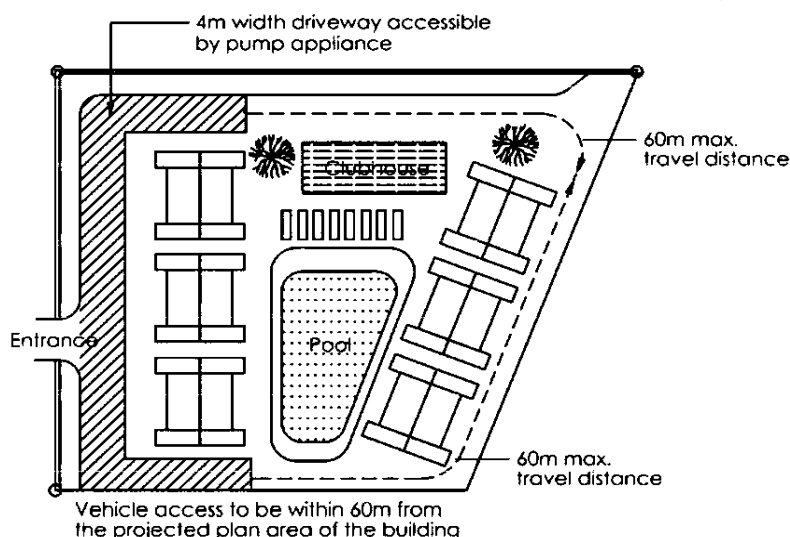

Diagram 4.2.2(a)(i)

The measurement of the travel distance shall be the line of travel located outside the building, and shall not traverse across open sided porches or 1st storey void deck. The travel distance is the distance that a fire fighter would traverse while carrying a portable ladder or equipment.



- (iii) For buildings under Purpose Group II that exceed the habitable height of 10m, fire engine access road shall be provided within a travel distance of 18m to the entrance of all exit staircases where the landing valves (dry or wet riser) are provided in accordance with Cl.6.2.2(b). The fire engine access road shall have a minimum 4m width and designed to sustain the load of stationary 30 tonnes fire engine fighting appliance, and shall be provided within 18m of dry riser breaching inlets of the building. The breaching inlets shall be located at the exterior, readily visible and accessible from the fire engine access road.

EXPLANATIONS & ILLUSTRATIONS

4.2.2(a)

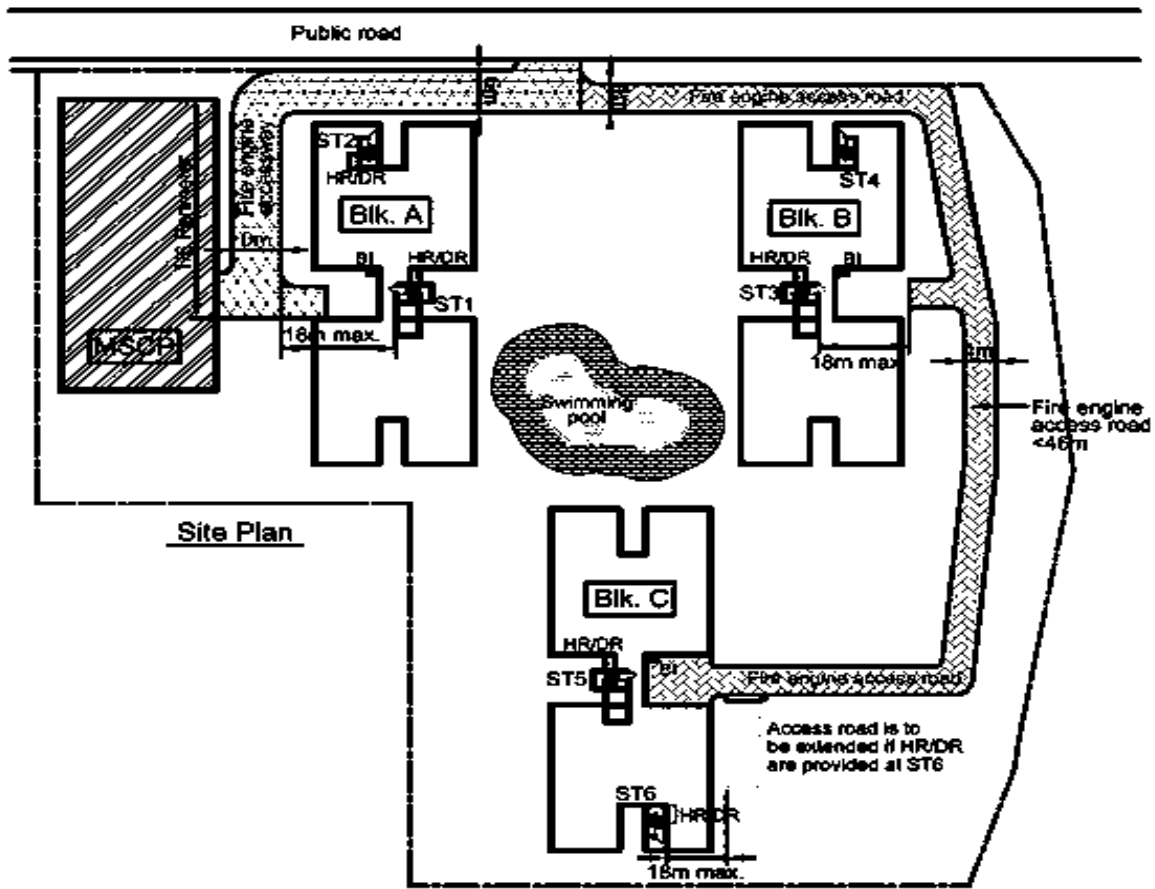

Diagram 4.2.2(a)(iii)

Blk. A, B & C exceeded 10m in habitable height, fire engine access road is within 18m from entrance ST1, ST3 & ST5 where dry risers are located fire engine access road is to be extended to ST2, ST4 & ST6 if dry riser is provided for these staircases due to insufficient coverage of the first.



- (iv) For buildings under purpose groups III, IV, V and VII not exceeding the habitable height of 10m, access way will not be required. However, provision of fire engine access road having minimum 4m width for pump appliance will be required to within a travel distance of 45m of every point on the projected plan area of the building.
- (v) In the case of basement, the fire engine access road shall be provided within a travel distance of 18m to the entrance of all exit staircases that are provided with landing valve (dry or wet riser) in accordance with C1.6.2.2 (b). The measurement of 18m shall be between the fire engine access road and the entrance of exit staircase.

EXPLANATIONS & ILLUSTRATIONS

4.2.2(a)

No illustration.



(b) For buildings under Purpose Groups III, IV, V and VII exceeding the habitable height of 10m, access way shall be located directly below the access openings to provide direct outreach to the access openings. Access way shall be provided based on the largest gross floor area of the following:

- (1) any floor including 1st storey,
- (2) If there is more than one floor interconnected, the aggregate areas of all the floor interconnected.

Minimum	$\frac{1}{6}$ perimeter (min 15m)
2000m ² to 4000m ²	$\frac{1}{4}$ perimeter
>4000m ² to 8000m ²	$\frac{1}{2}$ perimeter
>8000m ² to 16,000m ²	$\frac{3}{4}$ perimeter
>16000m ²	island site access

For buildings protected by an automatic sprinkler system, the floor area shall be doubled as follows:

Minimum	$\frac{1}{6}$ perimeter (min 15m)
4000m ² to 8000m ²	$\frac{1}{4}$ perimeter
>8000m ² to 16,000m ²	$\frac{1}{2}$ perimeter
>16,000m ² to 32,000m ²	$\frac{3}{4}$ perimeter
>32,000m ²	Island site access.

EXPLANATIONS & ILLUSTRATIONS

4.2.2

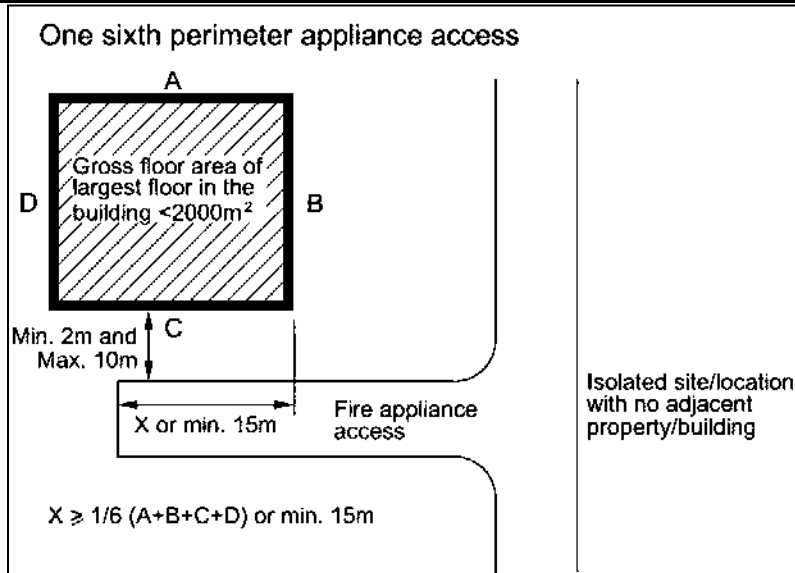

Diagram 4.2.2(b)(i)-1



EXPLANATIONS & ILLUSTRATIONS

4.2.2(b)

One fourth perimeter appliance access

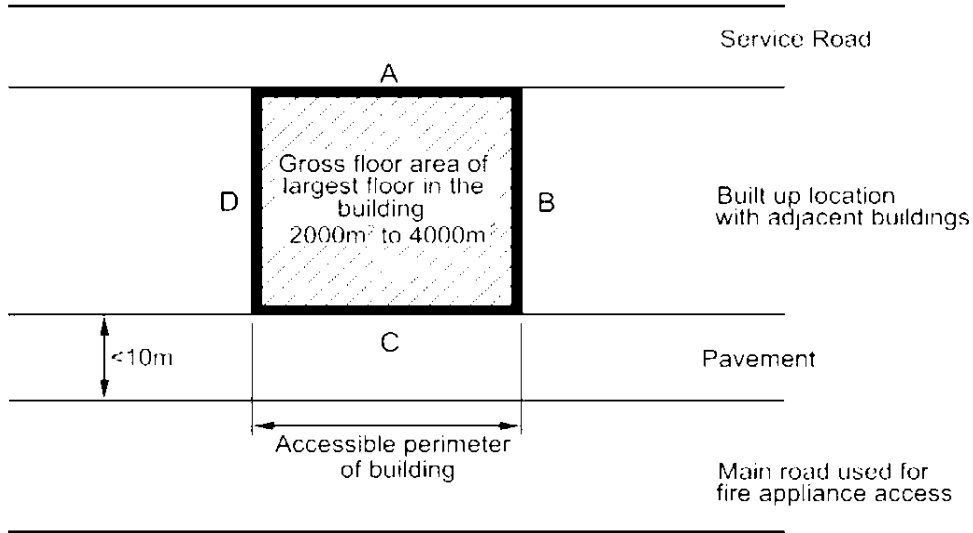
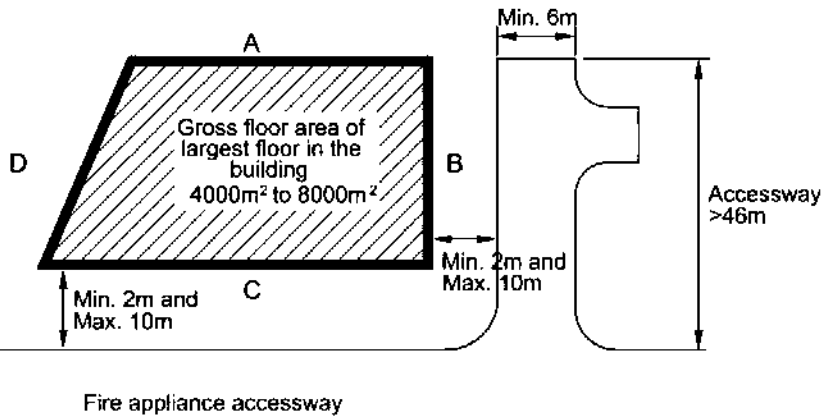

Diagram 4.2.2(b)(i)-2

In the event the service road (Minimum 6m) is accessible by fire fighting appliances and the building volume exceeds 2000m² but is less than 4000m², then $A + C \geq \frac{1}{4} (A + B + C + D)$

One half perimeter appliance access



$B+C \geq \frac{1}{2}(A+B+C+D)$

Diagram 4.2.2(b)(i)-3



- (c) (i) For buildings under Purpose Groups VI and VIII, access way shall be provided for fire-fighting appliances. The provision of access way shall be calculated based on the following gross cubical extent of the building as follows:

Minimum	$\frac{1}{6}$ perimeter (min 15m)
>28,400m ³	$\frac{1}{4}$ perimeter
>56,800m ³	$\frac{1}{2}$ perimeter
>85,200m ³	$\frac{3}{4}$ perimeter
>113,600m ³	island site access

For buildings protected by an automatic sprinkler system, the cubical extent of the building can be doubled as follows:

Minimum	$\frac{1}{6}$ perimeter (min 15m)
>56,800m ³	$\frac{1}{4}$ perimeter
>113,600m ³	$\frac{1}{2}$ perimeter
>170,400m ³	$\frac{3}{4}$ perimeter
>227,200m ³	Island site access.

EXPLANATIONS & ILLUSTRATIONS

4.2.2

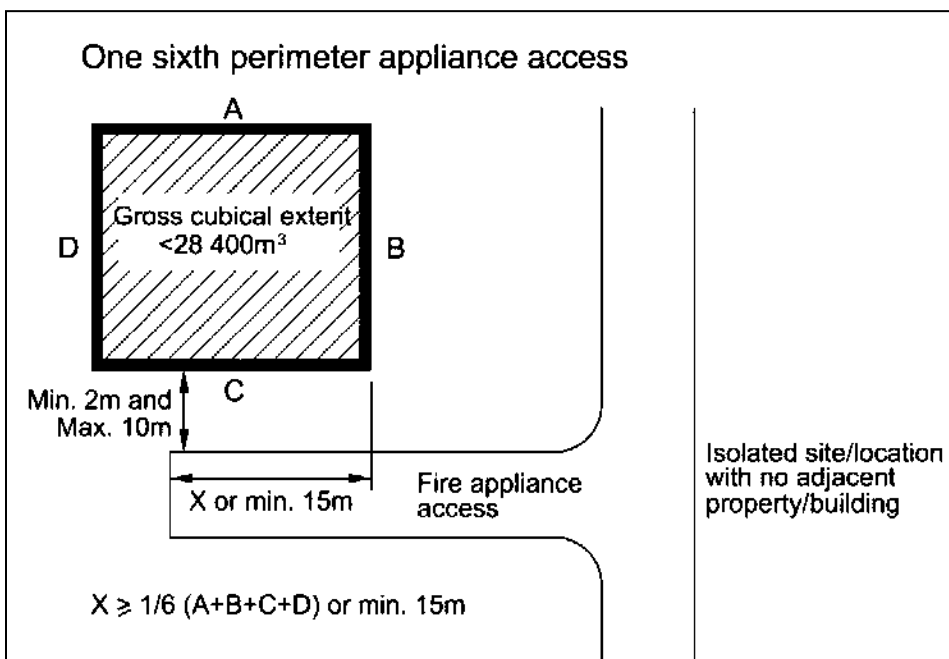

Diagram 4.2.2(c)(i)-1



EXPLANATIONS & ILLUSTRATIONS

4.2.2(c)

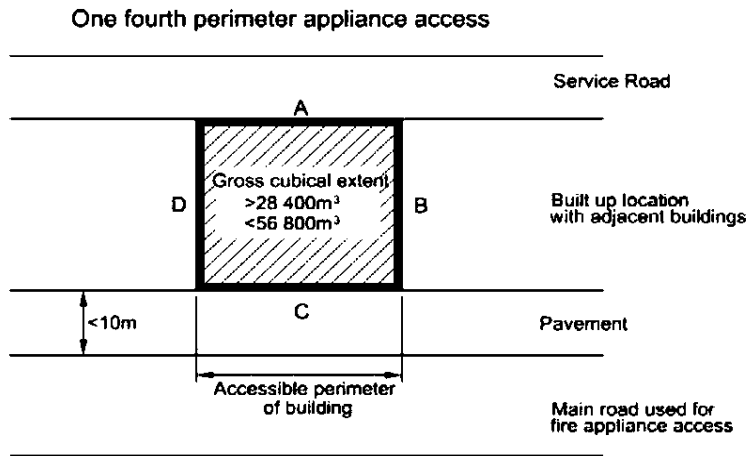

Diagram 4.2.2(c)(i)-2

In the event the service road (Minimum 6m) is accessible by fire fighting appliances and the building volume exceeds 28400m³ but is less than 56800m³, then $A + C \geq \frac{1}{4} (A + B + C + D)$

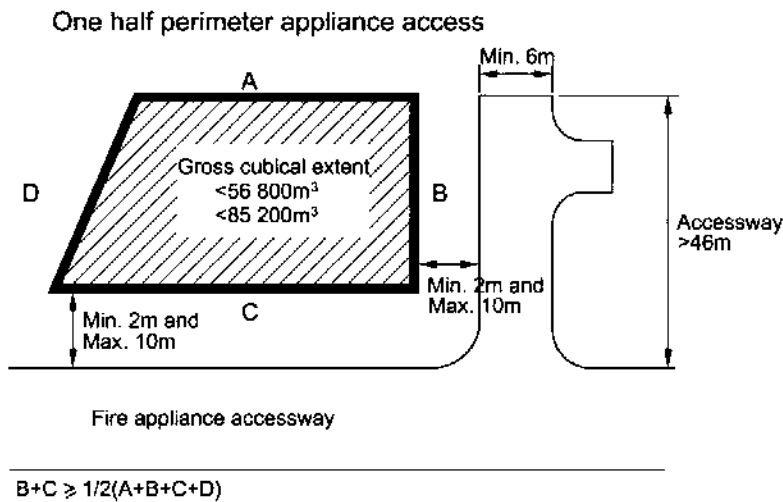

Diagram 4.2.2(c)(i)-3

a. The fire loads in industrial premises are much higher and fires could be more complex in nature, scale and magnitude compared to commercial buildings. Larger compartment sizes are common in such buildings especially in process and storage areas. The high rack storage of materials creates a large volume of combustibles.

b. It is important to note that for industrial buildings, the gross cubical extent is used for the calculation of the extent of access way required.

c. Sprinkler protected buildings

For buildings protected by an automatic sprinkler system, the cubical extent of the buildings can be doubled.



(d)(i) Access way

Access way shall be metalled or paved or laid with strengthened perforated slabs to withstand the loading capacity of stationary 30 tonnes fire-fighting appliance. Please see Appendix (7) for technical data on fire-fighting appliance.

(ii) Width of access way

The access way shall have a minimum width of 6m throughout. Such access way must be able to accommodate the entry and manoeuvring of fire engine, extended ladders pumping appliances, turntable and / or hydraulic platforms.

EXPLANATIONS & ILLUSTRATIONS

4.2.2

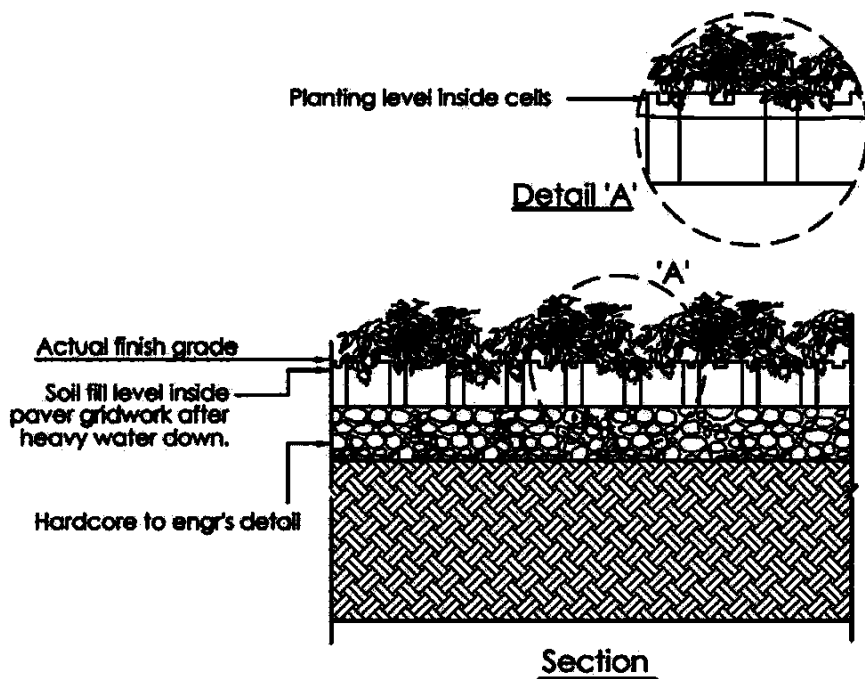

Diagram 4.2.2 (d)(i)

Access way needs to be designed to take the operating load of the fire engine. Diagram A to Appendix (7) Shows the location of footplates (jacks).

Where cellular or precast perforated slabs are to be used, they shall be of the approved type.

Gradient of 1:8.3 of normal driveway or access way could be used by fire engines for moving from one point to another. For fire engine access way the inclined gradient shall not exceeds 1:15 as the fire engine would not be able to operate.



(iii) Location

Access way shall be positioned so that the nearer edge shall be not less than 2m or more than 10m from the centre position of the access opening, measured horizontally.

(iv) Gradient of access way and access road

Access way shall be laid on a level platform or if on an incline, the gradient shall not exceed 1:15.
Access road shall be laid on an incline not exceeding a gradient of 1:8.3.

EXPLANATIONS & ILLUSTRATIONS

4.2.2(d)

No illustration.

(d)(v) Turning facilities

Dead-end access way and fire engine access road shall not exceed 46m in length or if exceeding 46m, be provided with turning facilities as shown in Diagram 4.2.2(d)(v).

(vi) The outer radius for turning of access way and fire engine access road shall comply with the requirements as shown in Diagram 4.2.2(d)(vi).

EXPLANATIONS & ILLUSTRATIONS

4.2.2(d)

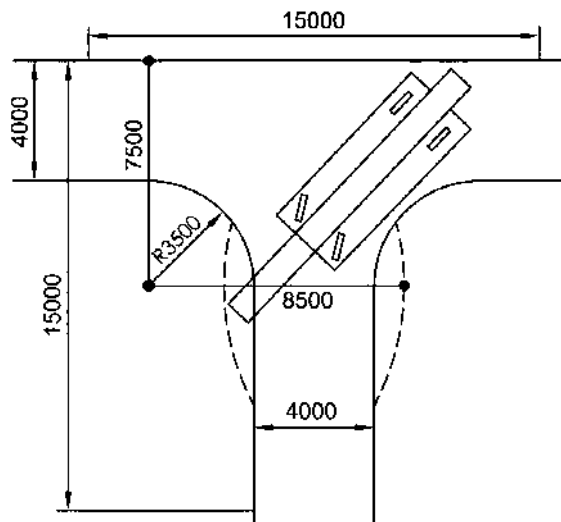

Diagram 4.2.2 (d)(v)-1

Turning Facilities for Pumper Appliances (24 tonnes)

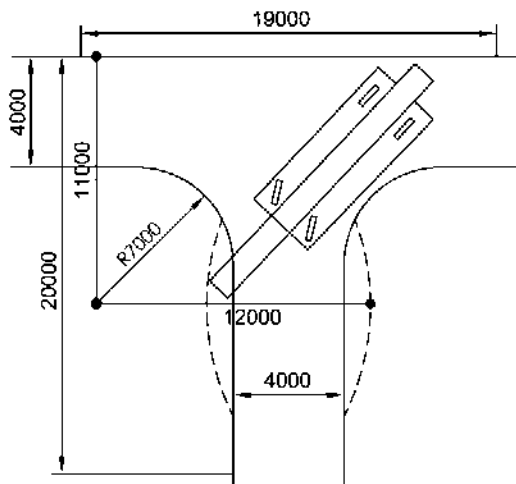

Diagram 4.2.2 (d)(v)-2

Turning Facilities for Aerial Appliances (30 tonnes)
Applicable to buildings exceeding the habitable height of 10m



EXPLANATIONS & ILLUSTRATIONS

4.2.2(d)(vi)

U-Turn Radii of Pumper Appliances (24 tonnes)

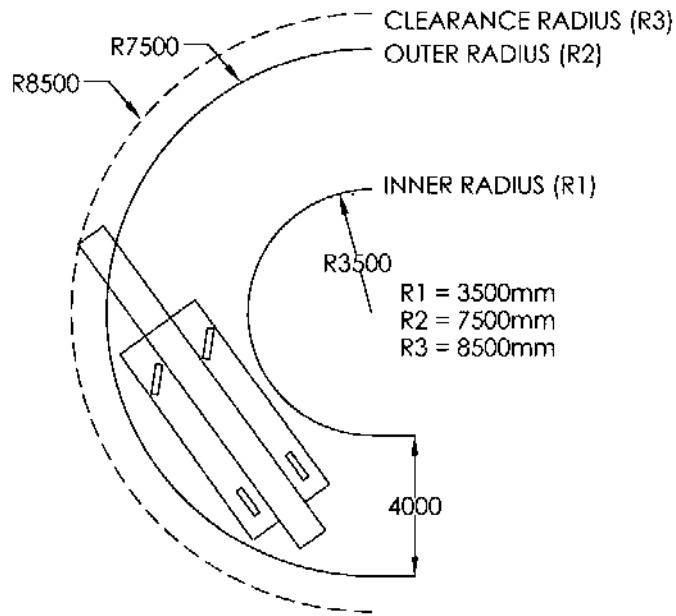

Diagram 4.2.2 (d)(vi)-1

U-Turn Radii of Aerial Appliances (30 tonnes)

Applicable to buildings exceeding the habitable height of 10m

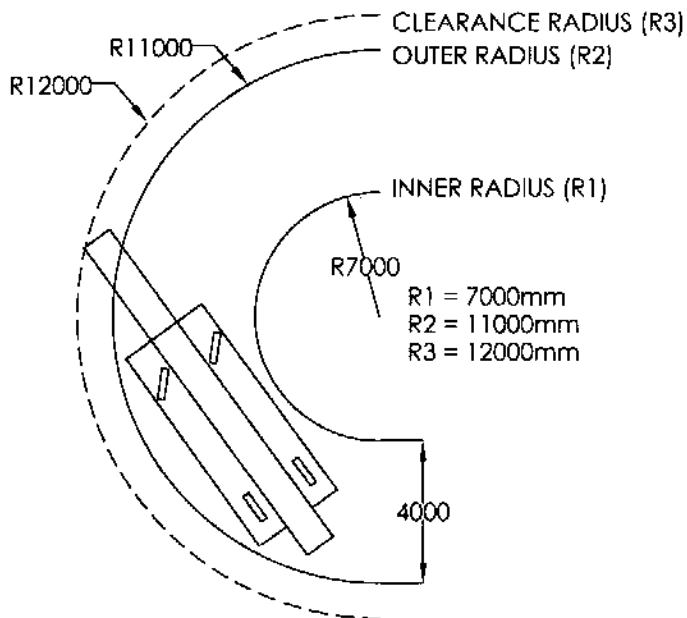

Diagram 4.2.2(d)(vi)-2



(d)(vii) Overhead clearance

Overhead clearance of access way and fire engine access road shall be at least 4.5m for passage of fire fighting appliances.

(viii) Public road

Public roads can serve as access way provided the location of such public roads is in compliance with the requirements of distance from access openings.

EXPLANATIONS & ILLUSTRATIONS

4.2.2(d)

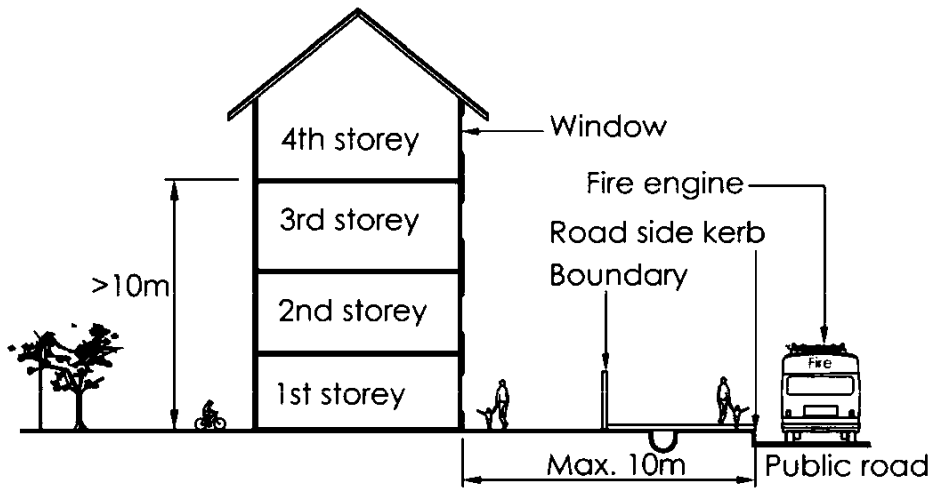

Diagram 4.2.2(d)(viii)-1

Elevation of building to the edge of road kerb shall not exceed 10m, in order to permit external fire fighting and rescue from the fire appliance parked on public road.



EXPLANATIONS & ILLUSTRATIONS

4.2.2(d)(viii)

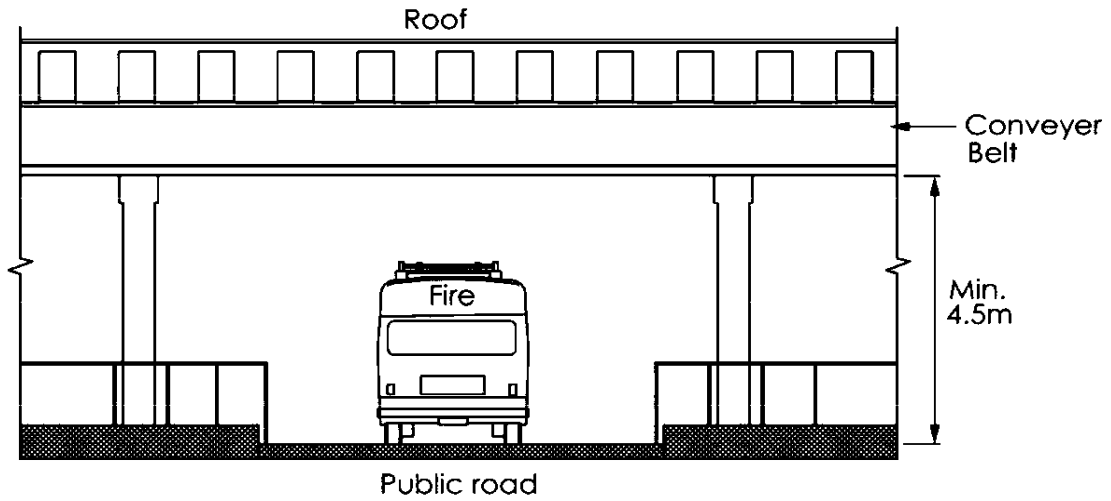

Diagram 4.2.2(d)(viii)-2

Overhead obstruction to access way could be entrance gate, conveyor belts, pipe racks or bridges connecting buildings etc. Public road may be used as access way by fire-fighting appliance, provided the edge of the public road to the facade of the building where access openings are located should not exceed 10m.



(ix) Obstruction

Access way and fire engine access road shall be kept clear of obstructions and other parts of the building, plants, trees or other fixtures shall not obstruct the path between the access way and access openings.

EXPLANATIONS & ILLUSTRATIONS

4.2.2(d)

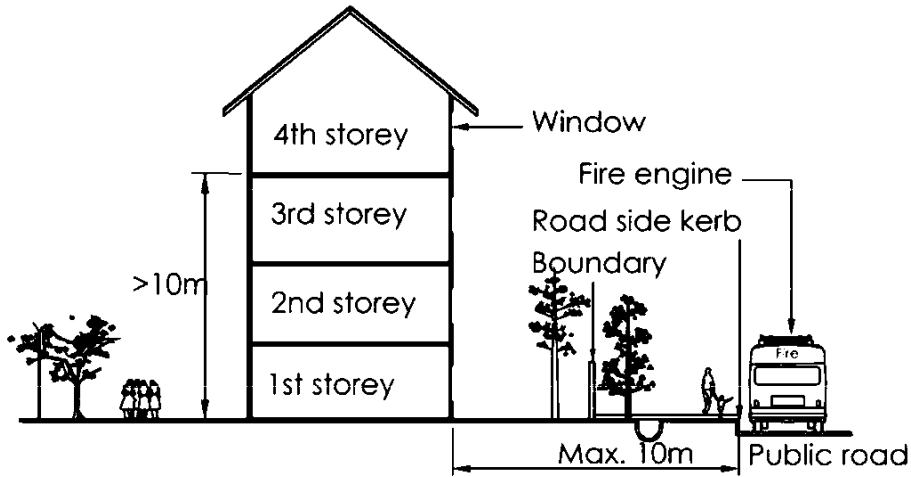

Diagram 4.2.2(d)(ix)-1

Trees causing obstruction to external rescue and fire fighting.

Note: There is no requirement to provide fire engine access and access way to buildings under Purpose Group I.



EXPLANATIONS & ILLUSTRATIONS

4.2.2(d)(ix)

Not Acceptable

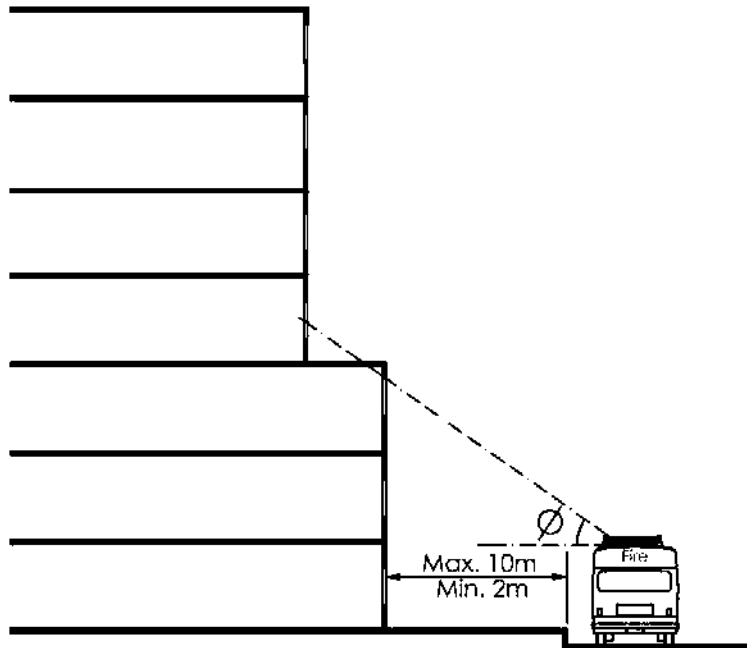

Diagram 4.2.2(d)(ix)-2

The podium edge is obstructing the reach of the boom of fire fighting appliance to 4th storey. Other obstructions could be roadside trees, entrance porch etc. To allow full extension of aerial ladders at a safe climbing or elevation angle Ø of 60 to 80 degrees, sufficient space is needed to position the fire engine.



EXPLANATIONS & ILLUSTRATIONS

4.2.2(d)(ix)

Acceptable

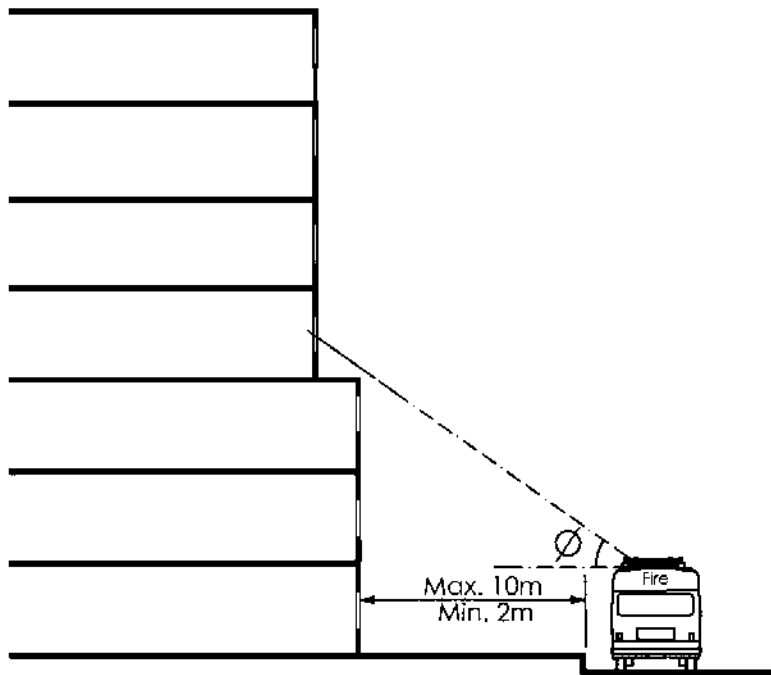

Diagram 4.2.2(d)(ix)-3

Tower block is relocated nearer to the edge of the podium base to avoid obstruction to the boom of fire fighting appliance.

The fire fighting appliance shall be located at least 2m, but not more than 10m away from the external wall or façade (including any overhead obstruction) of the building. If the fire fighting appliance is located within 2m from the building, the aerial ladder when set-up would fall outside the safe working limit ie. the inclination of the ladder would be too steep.

If the fire fighting appliance is located more than 10m from the building, the effective reach of the aerial ladder would be reduced.



EXPLANATIONS & ILLUSTRATIONS

4.2.2(d)(ix)

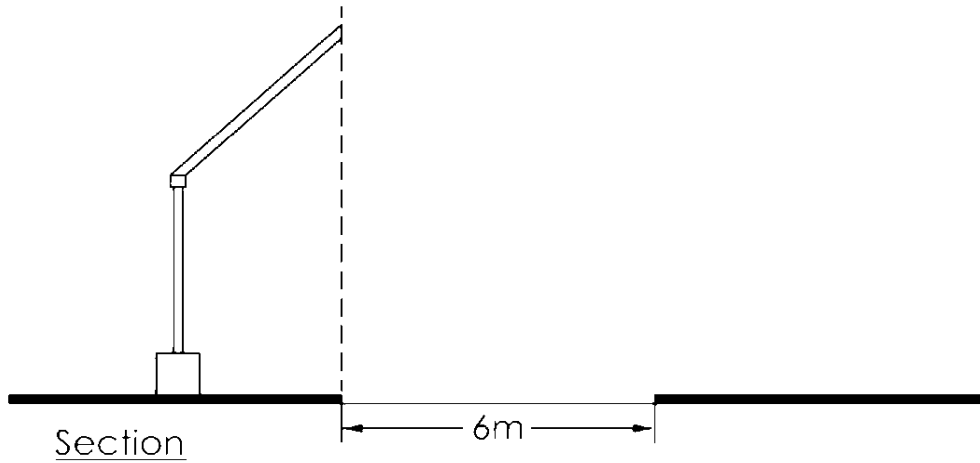

Diagram 4.2.2(d)(ix)-4

The security barrier, when lifted up, shall not obstruct the fire engine access way.

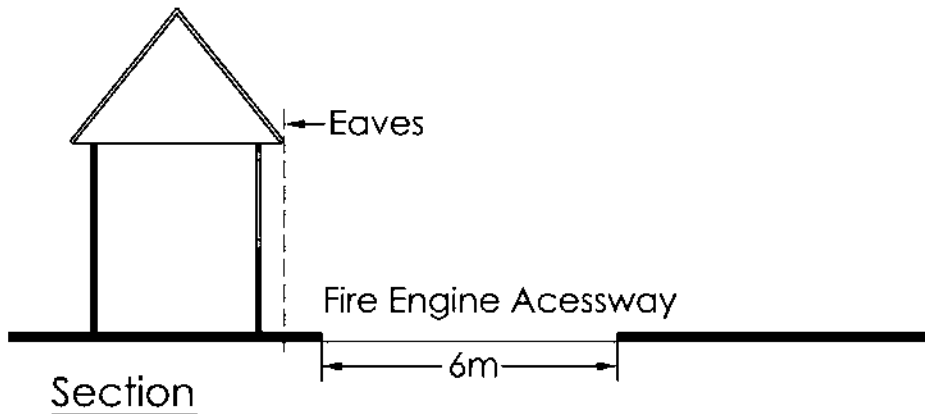

Diagram 4.2.2(d)(ix)-5

Eaves of the security post / guard house shall not project into the fire engine access way.



(e) Marking of fire engine access way

- (i) All corners of access way shall be marked.
- (ii) Marking of corners shall be in contrasting colour to the ground surfaces or finishes.
- (iii) Access way provided on turfed area must be marked with contrasting object (preferably reflective) that is visible at night. The markings are to be at an interval not more than 3m apart and shall be provided on both sides of the access way.
- (iv) Sign post displaying the wordings 'Fire Engine Access - Keep Clear' shall be provided at the entrance of the access way. Size of wordings shall not be less than 50mm.

EXPLANATIONS & ILLUSTRATIONS

4.2.2

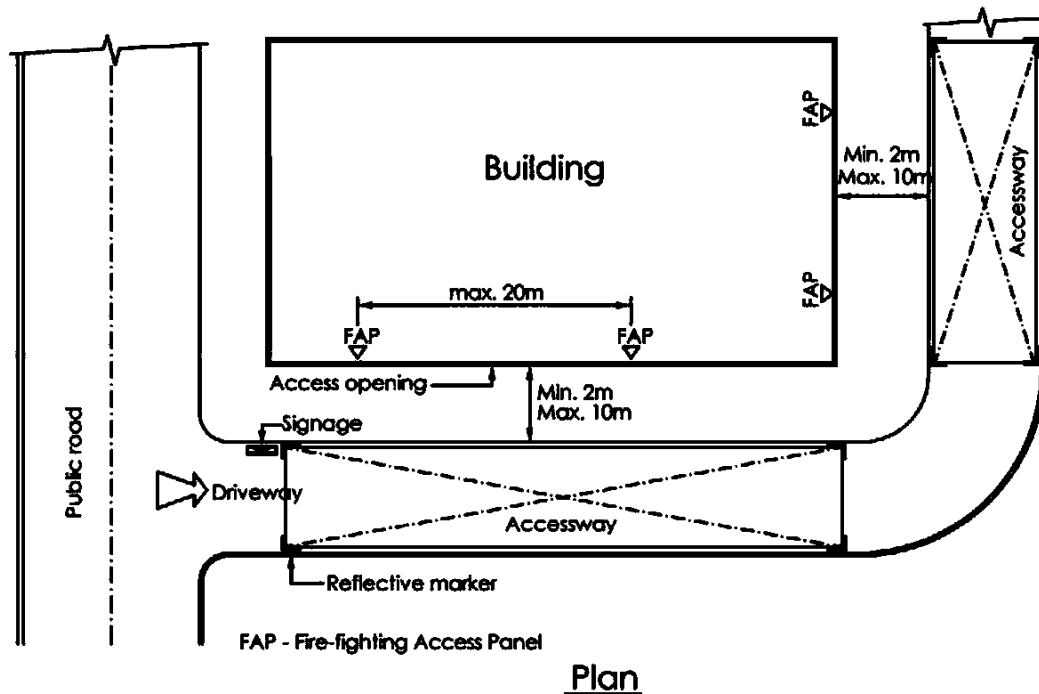

Plan

Diagram 4.2.2(e)-1

Access way, which is specially designated for operation of the fire fighting appliance, should be marked with signage to prevent unauthorised parking of other vehicles. It should be properly highlighted with contrasting colours to its surrounding for better visibility and easy identification by the responding fire fighting crew.

Reflective material should also be used to demarcate the access way space. This would help the fire fighters to locate it readily when responding to a fire incident at night. It is also important to note that fire fighting appliance is set up at the designated access way, especially so when it could be located over 'suspended' or 'cantilevered' slabs over basement etc. to prevent damage to building structures, if otherwise operated elsewhere.



EXPLANATIONS & ILLUSTRATIONS

4.2.2(e)

ACCEPTABLE

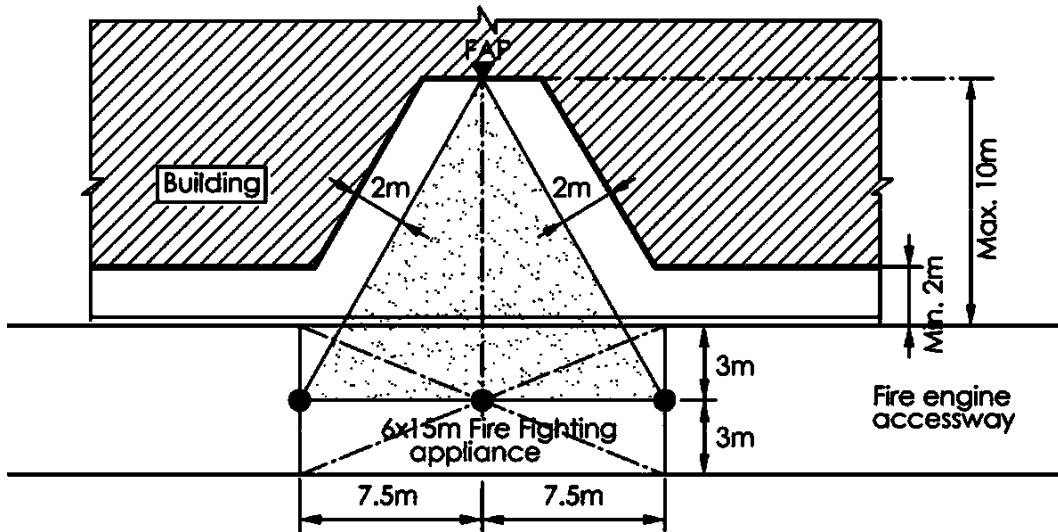
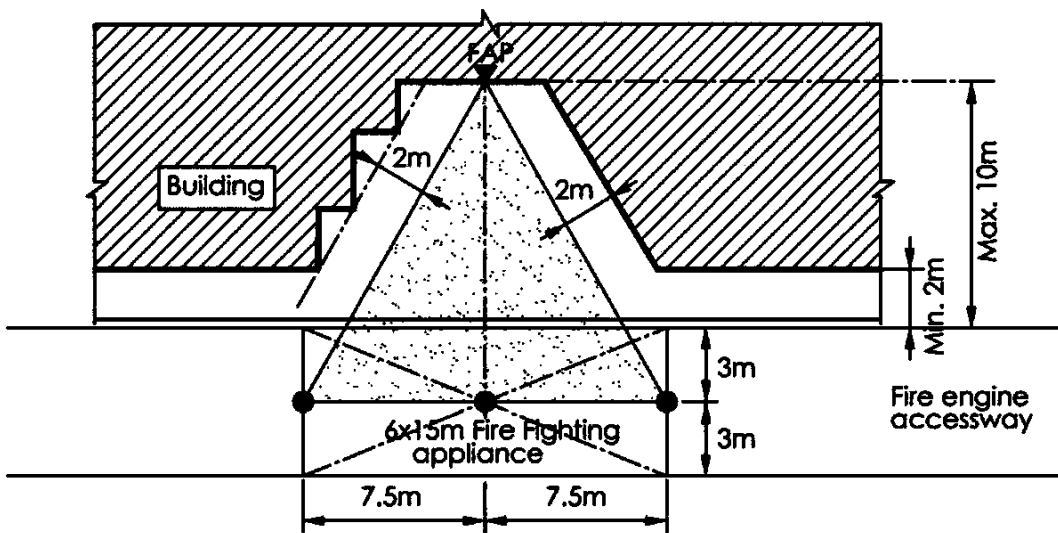

Diagram 4.2.2(e)-2



 Working space of boom in relation to FAP

Diagram 4.2.2(e)-3

The above illustrations are acceptable versions. A 2m wide free working space is available on both sides of the FAP to allow extension of fire engine boom located within hard standing to the FAP. Strictly interpreting the above sub clause, where hard standing is positioned from the centre of access opening measured horizontally, the entire 15m length of the facade of the building facing the fire engine access way shall be kept clear of obstructions.

EXPLANATIONS & ILLUSTRATIONS

4.2.2(e)

NOT ACCEPTABLE

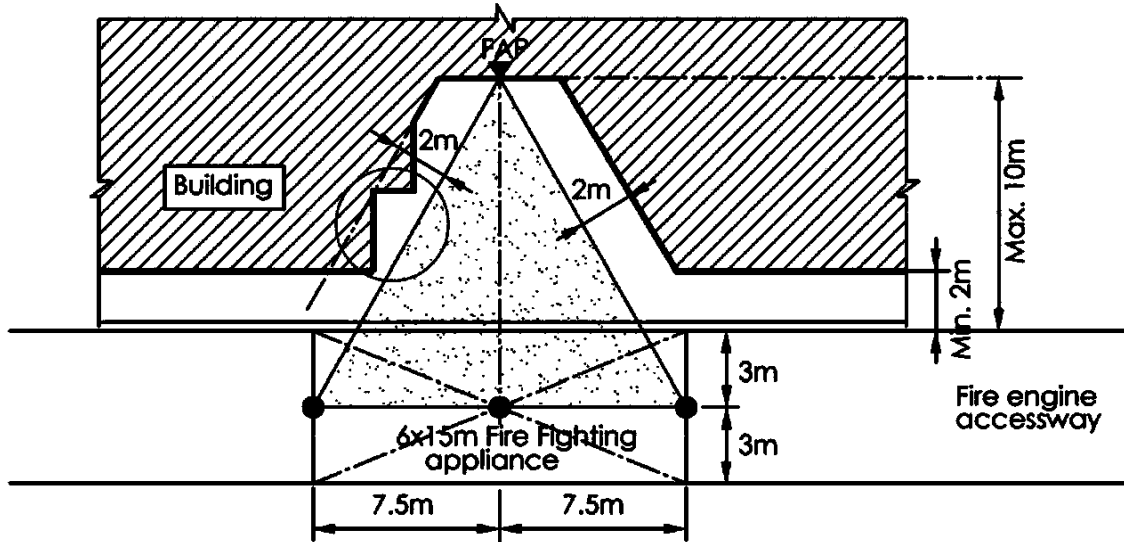
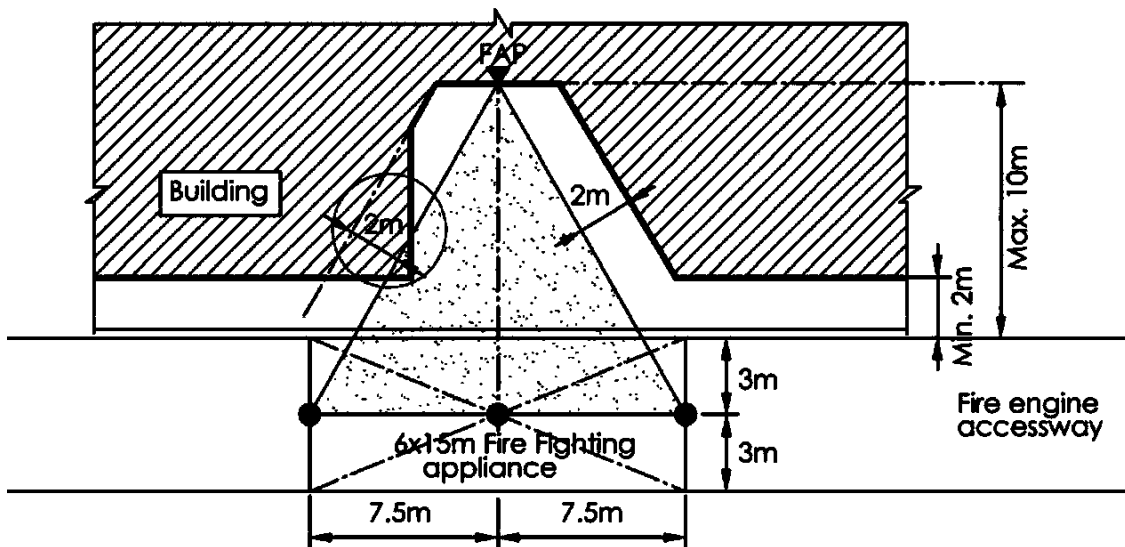

Diagram 4.2.2(e)-4



 Working space of boom in relation to FAP

Diagram 4.2.2(e)-5

Diagrams 4.2.2(e)-4 and 5 illustrate building structures being sited within and beyond the 2m working space required for the safe operation of the extended boom of the fire engine.



EXPLANATIONS & ILLUSTRATIONS

4.2.2(e)

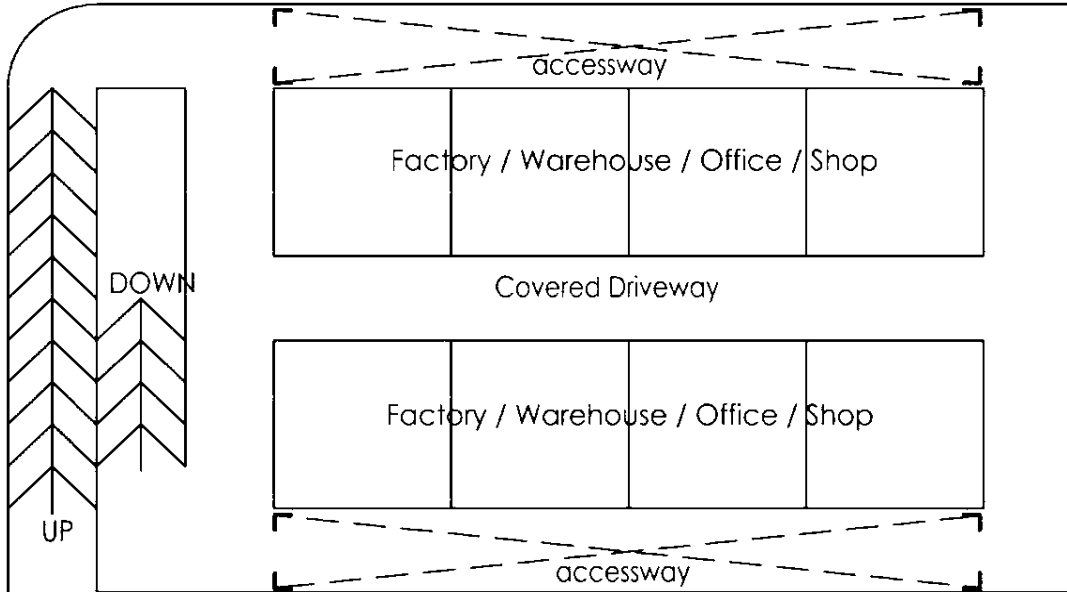

4th Storey Plan

Diagram 4.2.2(e)-6

The above floor plan shows the elevated base and the footprint of a stack-up factory/warehouse building.

The access way is marked at each corner. The fire fighters are required to pitch the fire fighting appliances only within the designated access way, which is hardened to take the additional load that would be imposed by the appliances. Damage to the floor slab would occur if the fire fighting appliances are pitched outside the designated access way, which is not hardened to receive the pitching of fire fighting appliances.



CHAPTER 4

4.2 PROVISION FOR EXTERNAL ACCESS TO BUILDING FOR FIRE FIGHTING AND ACCESSIBILITY OF SITE TO FIRE FIGHTING APPLIANCES

4.2.3 ACCESS OPENING TO BUILDING FOR FIRE FIGHTING

(a) Definition

Openings on the external wall for external fire fighting and rescue operation. Access openings shall include unobstructed external wall openings, windows, balcony doors, glazed wall panels or access panels. Windows, doors, wall panels or access panels must be readily openable from the inside and outside. Inside and outside of access openings shall be unobstructed at all times during the occupancy of the building.

EXPLANATIONS & ILLUSTRATIONS

Balcony is acceptable for access

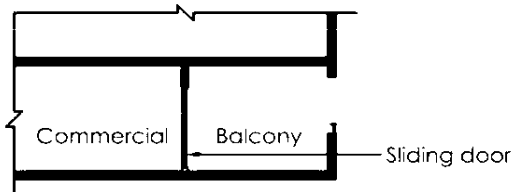

Fig. (i)

Window serving as access opening

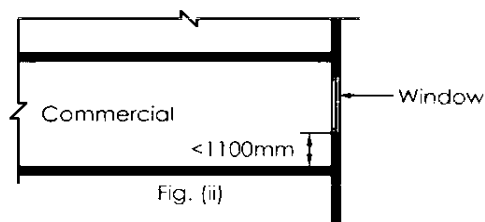

Fig. (ii)

Designated openable panel in curtain walling is acceptable

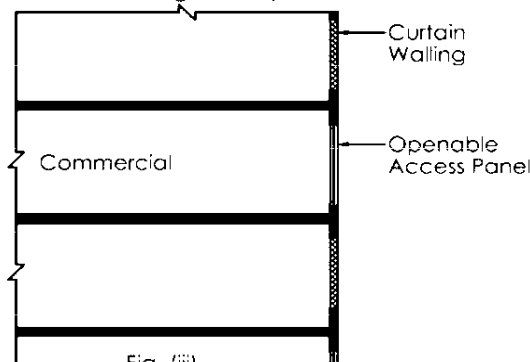

Fig. (iii)

Not acceptable to use high level louvres window to toilet as access

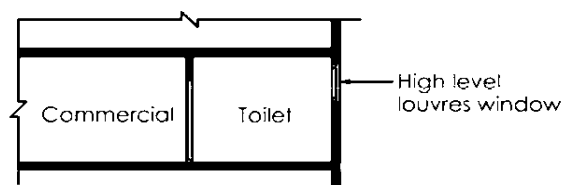

Fig. (iv)

Diagram 4.2.3(a)-1

EXPLANATIONS & ILLUSTRATIONS

4.2.3(a)

Section of sunshading in front of FAP shall be made readily removable

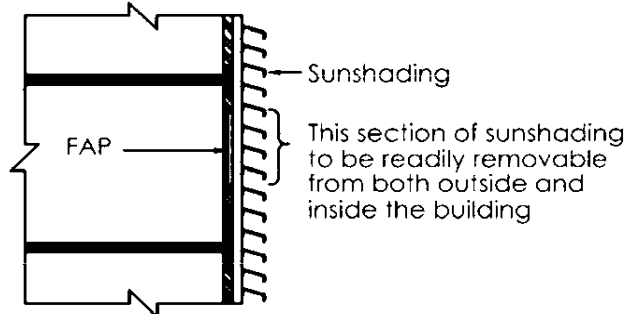

Fig. (v)

Not Acceptable
- overhead obstruction of FAP

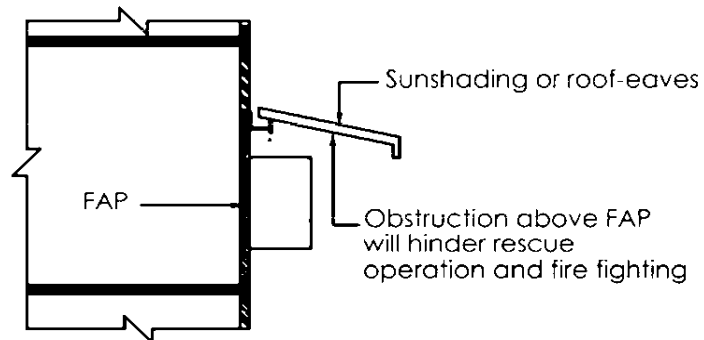

Fig. (vi)

FAP: Fire-fighting Access Panel

Diagram 4.2.3(a)-2

The purpose of the access opening is to enable fire fighters to gain access from external to rescue any occupant who is trapped in the building and to allow fire fighting from the outside of building. Access panels shall be placed at habitable spaces. In situation where the upper storey of a building is windowless, the FAPs could also be used for smoke and heat venting.

Access opening shall not be located at protected staircases or lobbies. As these spaces are being protected, there is no need for fire fighters to gain access into them from the outside.

Sun shading to window shall be designed to have openable section in front of the designated FAP. Qualified Person should consult MFRS for FAPs that are obstructed by the sun shading and seek acceptance on the method of opening or removal of that section of sun shading in front of the FAP before building plan submission.



- (b) Where an external wall which faces the access way has external openings on each storey level that meet the requirements of sub-clauses 4.2.3(a), 4.2.3(e) and 4.2.3(f), there is no need to designate any access opening.
- (c) An external wall which faces the access way and is windowless or a blank-wall shall be provided with access openings at each storey level.
- (d) Panels to access openings shall be posted with either a red or orange triangle of equal sides (minimum 150mm on each side), which can be upright or inverted, on the external side of the wall and with wordings "Fire Fighting Access - Do Not Obstruct" of at least 25 mm height on the internal side.

EXPLANATIONS & ILLUSTRATIONS

4.2.3

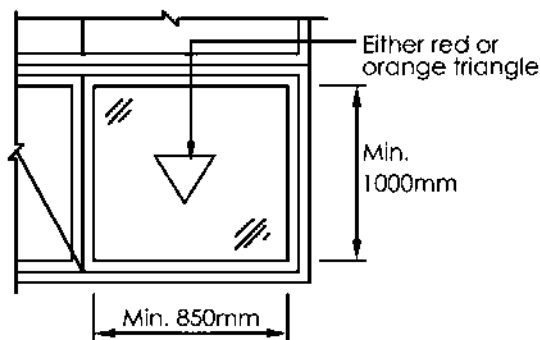

External view

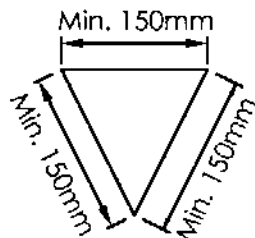

Fire Fighting Access
Do Not Obstruct

Min. 25mm

Internal view

Diagram 4.2.3(d)

The signage, either in red or orange triangle would help fire fighters on the ground to locate the designated access openings. The triangle can be upright or inverted.



(e) Access openings shall be not less than 850mm wide by 1000mm high with sill height of not more than 1100mm and head height not less than 1800mm above the inside floor level. The access opening shall not be placed at plant/store room, staircase, smoke-stop lobby or “dead space”. It shall be placed against an occupied space.

EXPLANATIONS & ILLUSTRATIONS

4.2.3

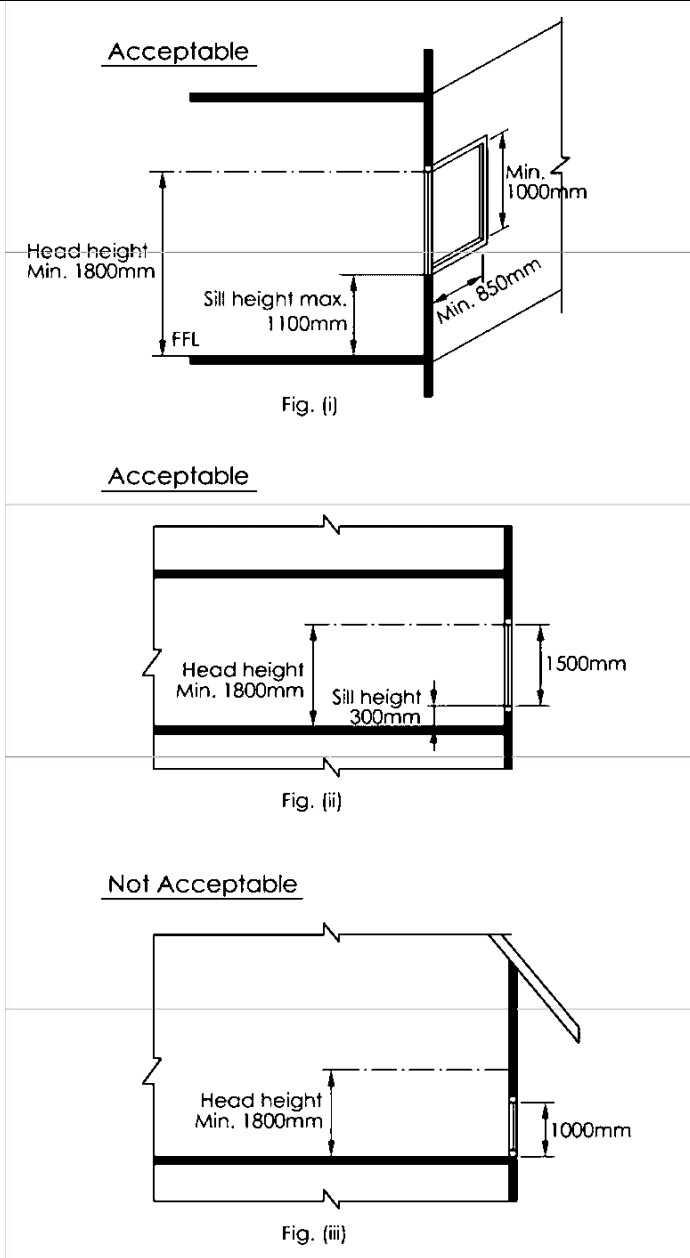

Diagram 4.2.3(e)-1

In Fig. (iii), although the height of access opening complies with the Clause (1000mm), the head height is less than 1800mm.



EXPLANATIONS & ILLUSTRATIONS 4.2.3(e)

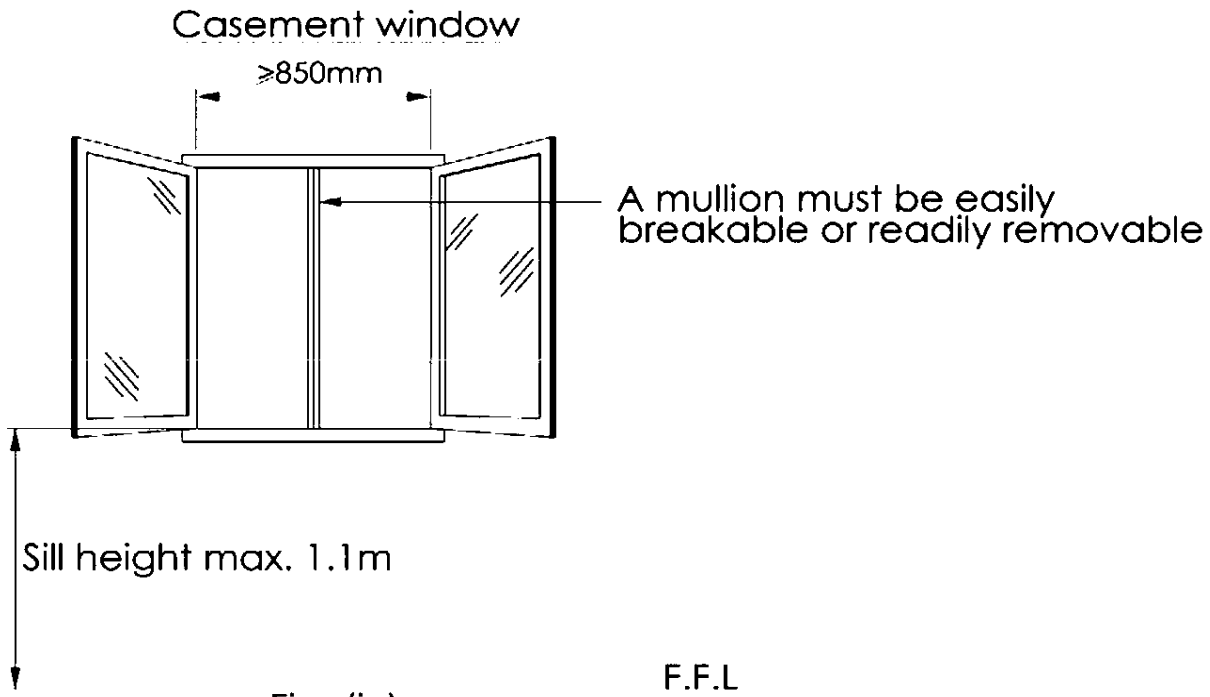

Fig. (iv)

F.F.L

Diagram 4.2.3(e)-2

Signage shall be provided to indicate the access openings, both inside and outside habitable rooms to prevent any obstruction at all times. High-level access openings are not acceptable as fire fighters could incur physical injuries if they fall down from the opening when trying to gain access into the building. The sill height of not more than 1100mm is to facilitate the free movement in/out of the building. Higher sill height would pose problems as fire fighter could incur a fall when entering the building and restrict movement.

The minimum width of 850m shall not include a mullion usually found in casement windows. The provision of mullion would reduce the access opening. This would cause difficulties to fire fighters when trying to get into or out of the building, carrying with them equipment or injured occupant.



- (f) Number and position of access openings for buildings other than residential:
 - (i) Buildings other than residential
For buildings under Purpose Groups III, IV, V and VII exceeding the habitable height of 10m up to 60m, access opening is required at every storey level, other than 1st storey, opening directly onto access way.
 - (ii) Access opening to compartment or spaces
For building under Purpose Groups VI and VIII, access openings located over access way shall be provided and evenly distributed along the external walls up to a habitable height of 60m.
 - (iii) Access openings shall be remote from each other and located along the side of the building. Such access openings shall be spaced at not more than 20m apart measured along the external wall from centre to centre of the access openings.

EXPLANATIONS & ILLUSTRATIONS

4.2.3

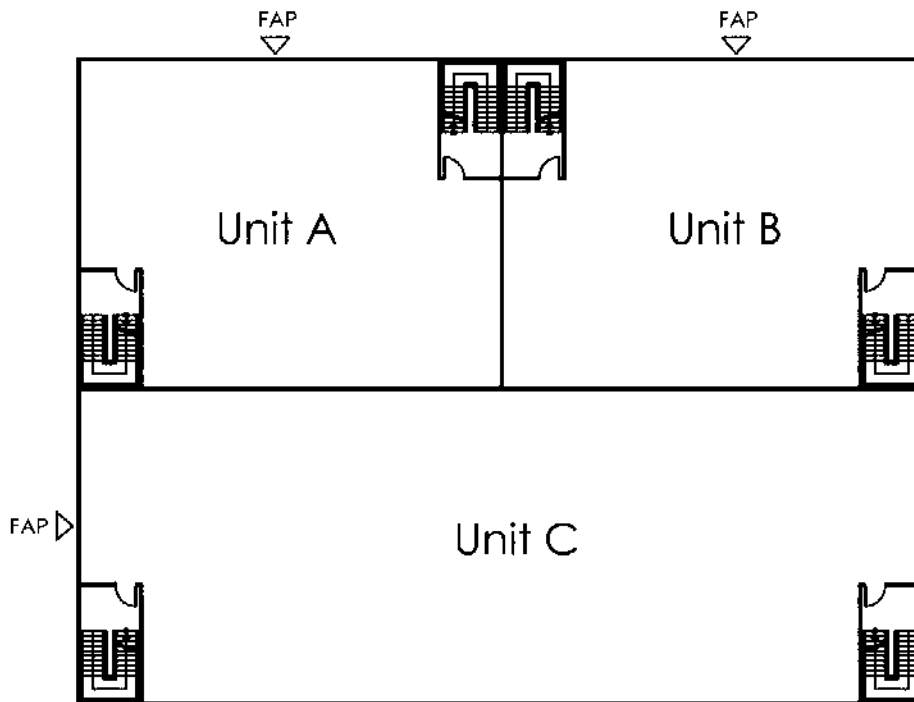

Diagram 4.2.3(f)(iii)-1

As the compartments are not accessible from one another, each compartment shall be provided with at least one access opening. FAPs are provided along the external wall overlooking the fire engine access way.



EXPLANATIONS & ILLUSTRATIONS

4.2.3(f)

Not Acceptable

Access opening in a dead space

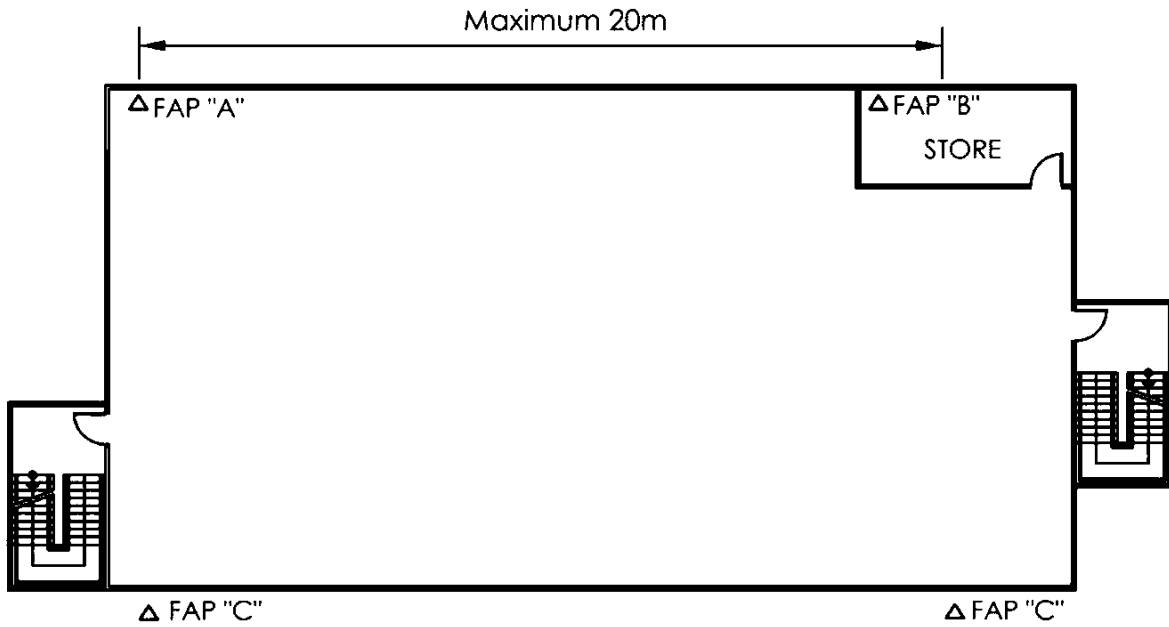

Diagram 4.2.3(f)(iii)-2

EXPLANATIONS & ILLUSTRATIONS

4.2.3(f)

Acceptable

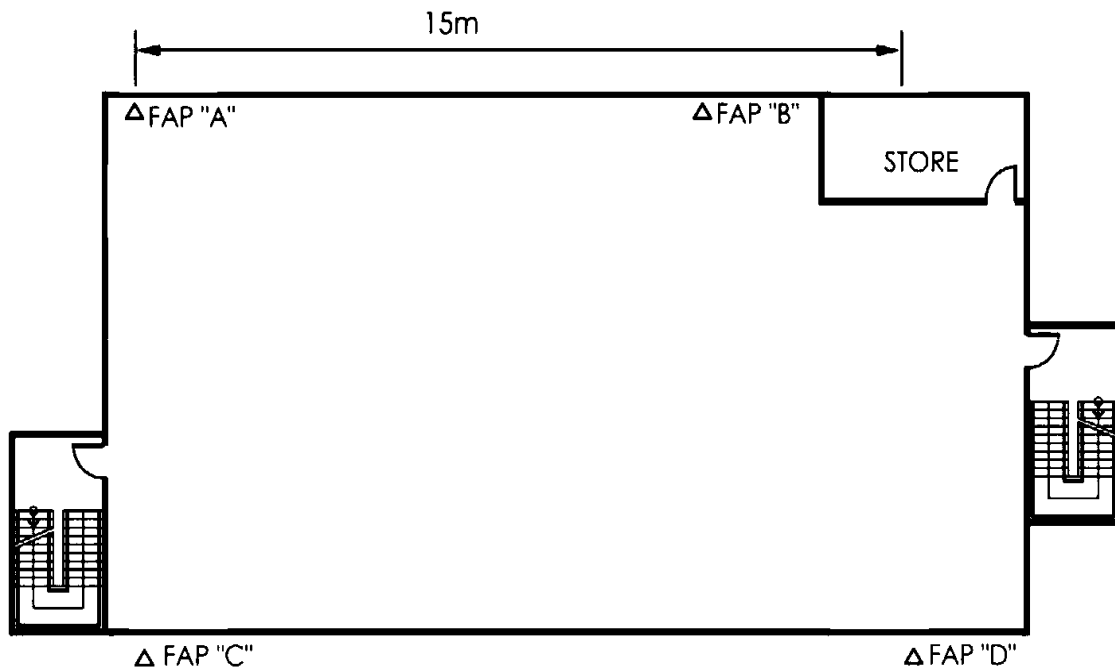

Diagram 4.2.3(f)(iii)-3

Location of access openings should not be rigidly governed by the 20m- apart rule, as access panels should open into “habitable space” Thus, providing access openings at a “dead space” or “store room” is not allowed. However, access openings at the following areas should be avoided:

- a) Staircases
- b) smoke stop lobbies

The distance between access openings may vary as deemed fit. It is not necessary to be 20m all the time. In some circumstances, it may be less than 20m, depending on the shape of the building, the floor layout and the usage of the various rooms at which access panels are being provided.

Access openings are meant for conducting rescue operation and fighting fires from the outside, while the fire fighter rides on an aerial ladder. Providing an access opening in the staircase will not serve much purpose. It is unlikely that the fire is in the staircase; and gaining access into the staircase directly should be possible without having to do it from the fire appliances.



EXPLANATIONS & ILLUSTRATIONS

4.2.3(f)

Acceptable

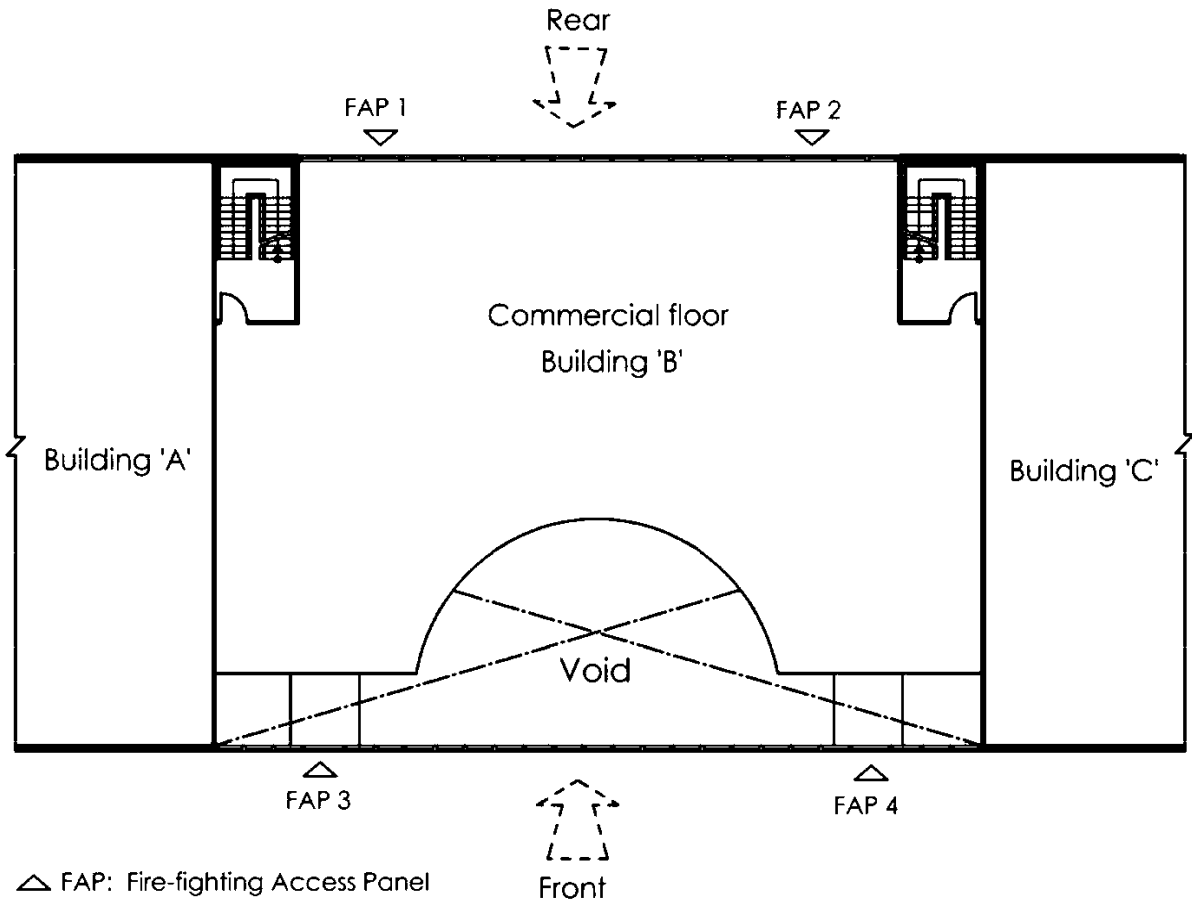

Diagram 4.2.3(f)(iii)-4

In situation where void or atrium interferes with the siting of FAPs, for example, FAPs 3 and 4 as shown in the above diagram, the Qualified Persons should consult MFRS to determine the alternative suitable location for the affected FAPs and the adequacy of the overall provision per storey of the building up to 60m habitable height.

FAP 3 and FAP 4 shall have direct access to the commercial floor.



EXPLANATIONS & ILLUSTRATIONS 4.2.3(f)

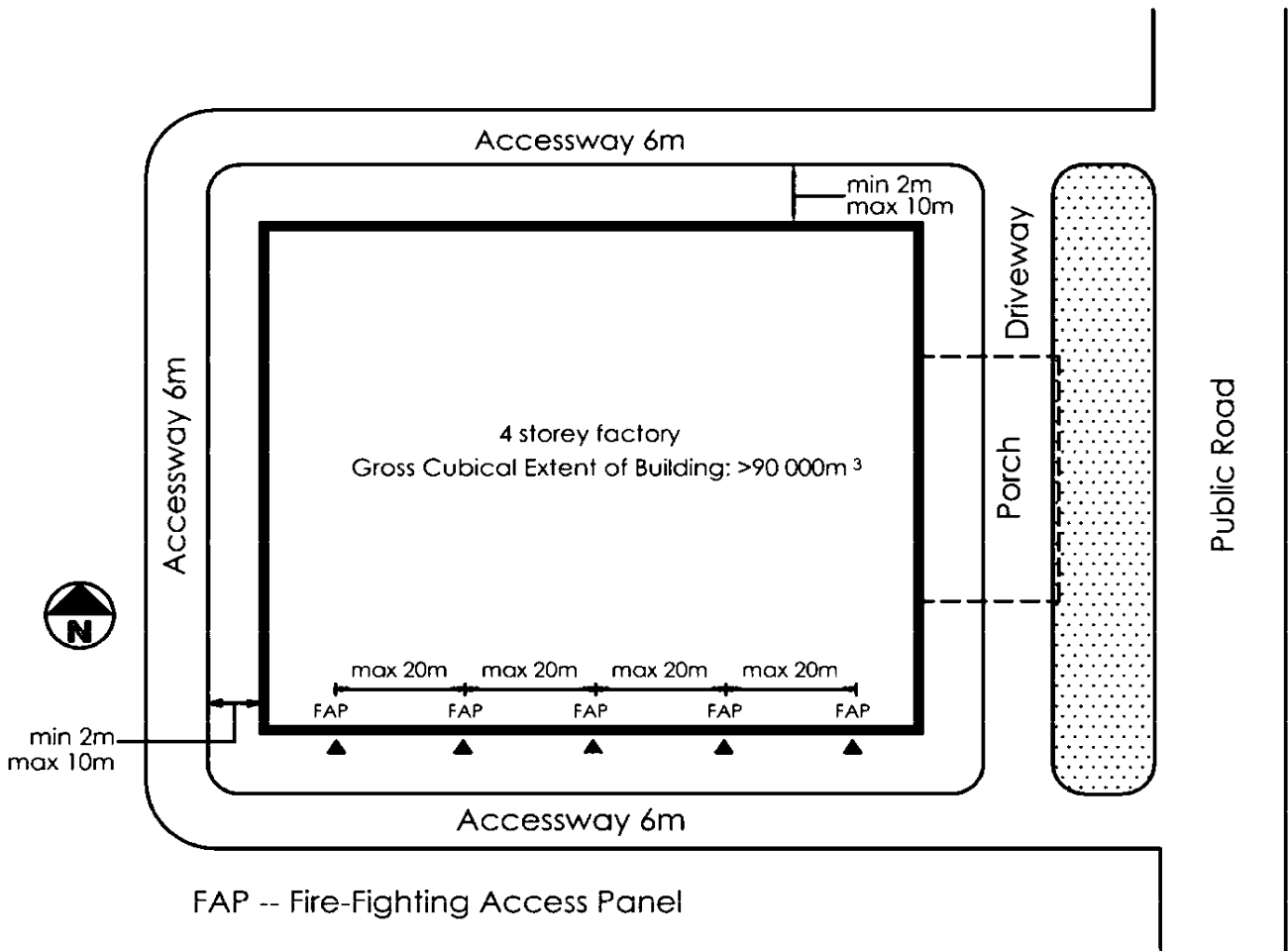

Diagram 4.2.3(f)(iii)-5

- a. The above diagram shows a 4 storey shopping centre which is sprinkler protected. The total gross floor area of the largest floor is about 20,000sq. m. Under Cl. 4.2.2(b), $\frac{3}{4}$ of the building perimeter would need to be provided with fire engine access way.
- b. North and west elevations which are provided with glass façade (the glazing used shall be breakable type) and having access openings meeting the requirements of Cl. 4.2.3(a) and 4.2.3(e) , there is no need to indicate the FAP or access openings.
- c. For South elevation which has solid wall façade, access openings (windows) or FAPs are required to be provided at intervals of not more than 20m apart.
- d. The glazing to the designated access openings shall be openable type from the outside.



EXPLANATIONS & ILLUSTRATIONS

4.2.3(f)

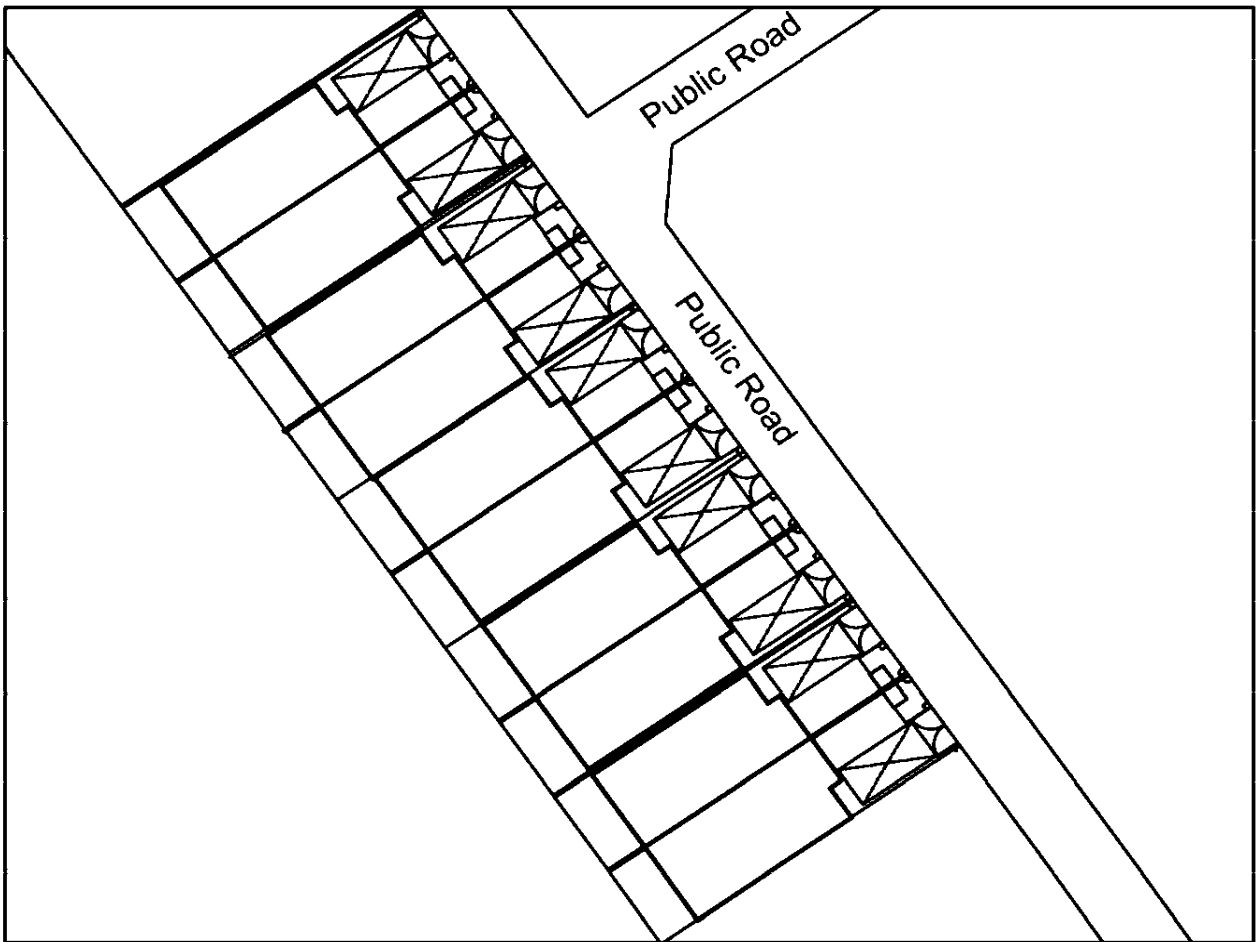

Location Plan

Diagram 4.2.3(f)(iii)-6



EXPLANATIONS & ILLUSTRATIONS

4.2.3(f)

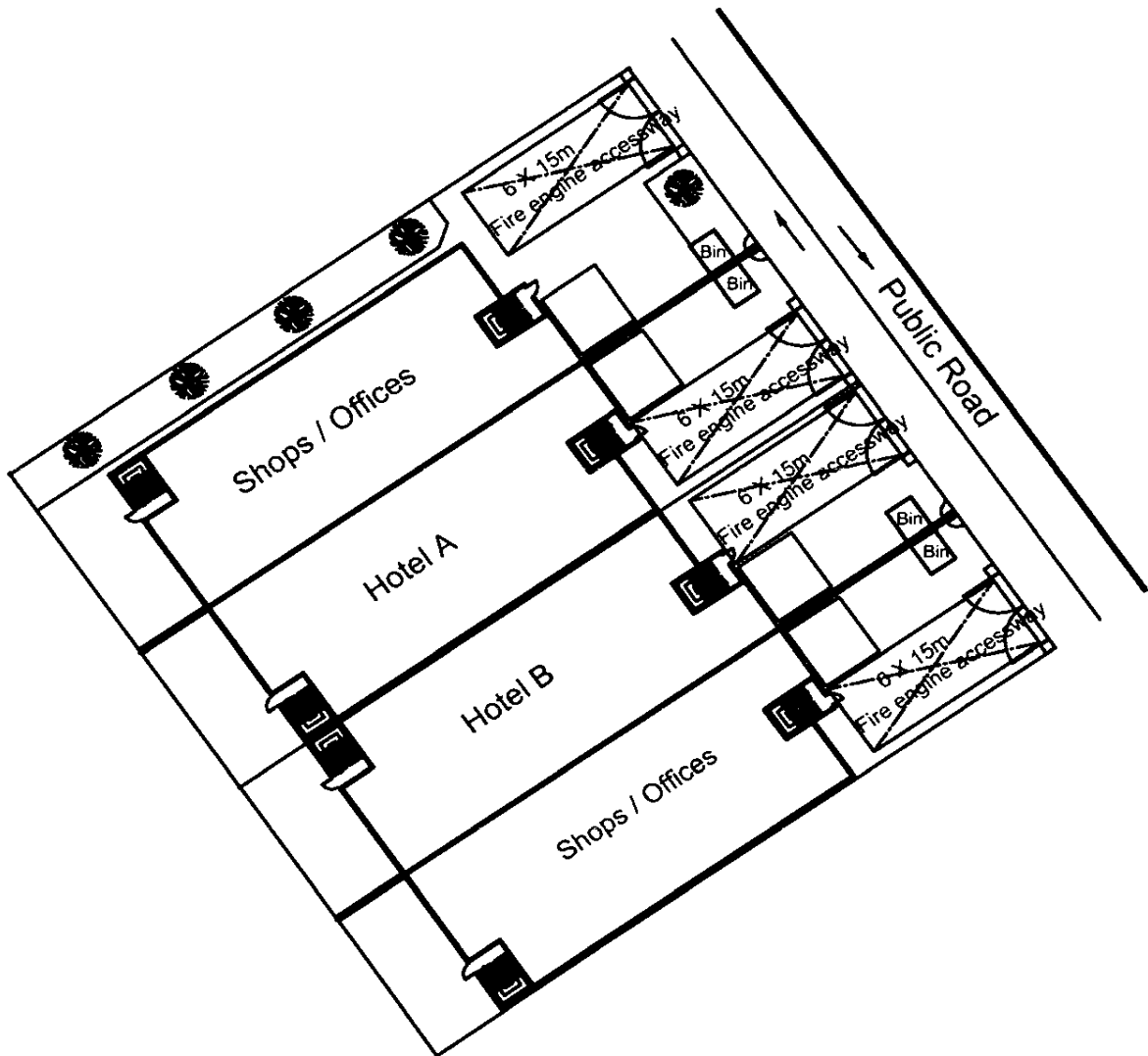

Proposed Plan

Diagram 4.2.3(f)(iii)-7

In long narrow sites, the provision of fire engine access way would affect the layout of the building. To compensate for the lack of fire engine access way, it would be necessary to provide internal fire fighting facilities such as sprinkler system, fire lift, wet or dry rising main., QP shall obtain waiver approvals prior to making building plan submission.



(iv) Additional openings

For buildings under Purpose Groups III IV, V, VI, VII and VIII where an area or space has a ceiling height greater than 10m, additional high level access openings for smoke venting and fire-fighting purposes shall be provided and located in the external walls opening into the area or space.

EXPLANATIONS & ILLUSTRATIONS

4.2.3(f)

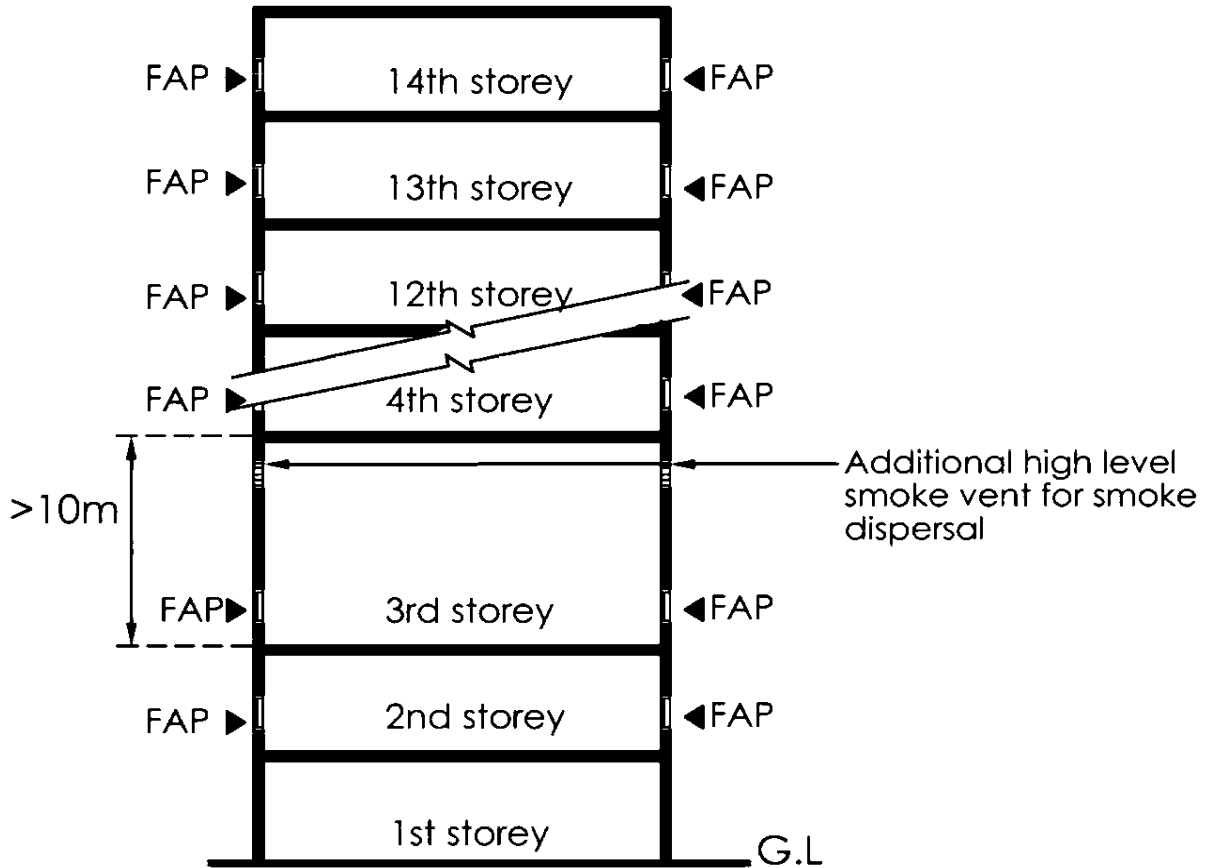

Section

FAP : Fire-fighting Access Panel

Diagram 4.2.3(f)(iv)

The additional openings are meant for smoke venting. It is not necessary to provide fire-fighting access panel, as there is no landing below the opening. The additional opening shall be labelled as 'Smoke Vent' of not less 25mm height.



(g) The provision of access openings shall not be applicable to buildings under Purpose Groups I and II, including buildings under Purpose Group II that have non-residential uses located in the same buildings.

EXPLANATIONS & ILLUSTRATIONS

4.2.3

No illustration.



CHAPTER 4

4.3 ACCESS TO BUILDING WITH RISING MAINS

4.3 Access to buildings with rising mains

Buildings fitted with rising mains and automatic sprinkler system shall have access ways for pumping appliances within 18m of the breaching inlet. The breaching inlets shall be visible from the access ways.

EXPLANATIONS & ILLUSTRATIONS

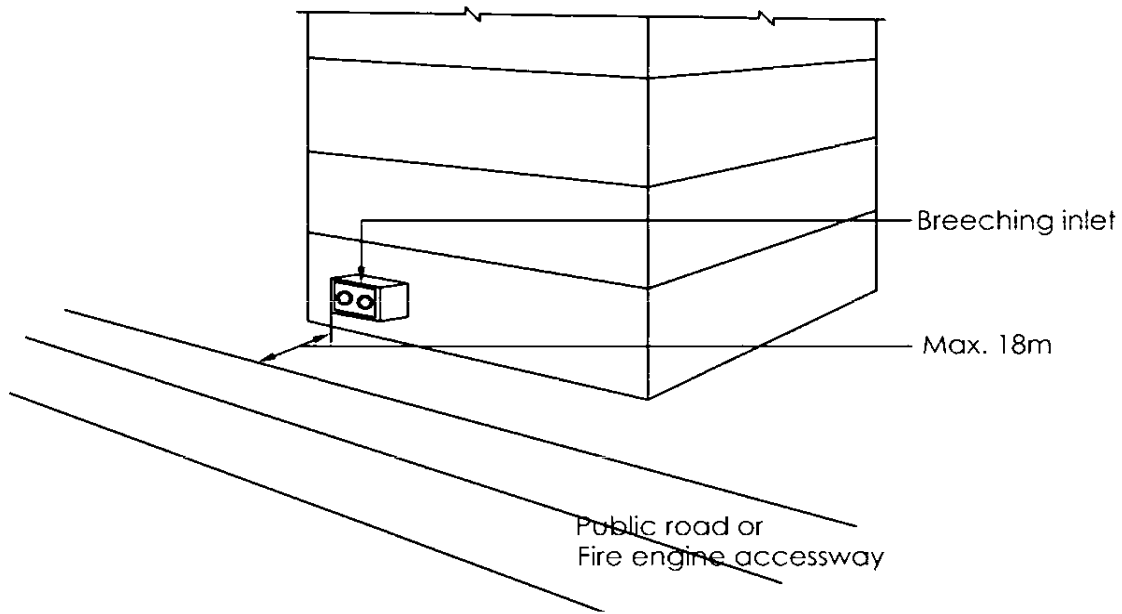

Diagram 4.3

Breaching inlets should be visible from access way to avoid delay in locating them upon arrival of fire crew. For better control and limit to one hose length being used, the breaching inlets shall not be sited more than 18m away from the access way.



CHAPTER 4

4.4 PRIVATE FIRE HYDRANT

4.4.1 REQUIREMENTS

(a)(i) Private fire hydrant

Every part of a fire engine access road and/or an access way in a private lot shall be within an unobstructed distance of 50m from a hydrant. Where a public hydrant conforming to such requirement is not available, private hydrant(s) shall be provided (see diagram 4.4.1(a)).

(ii) Existing public hydrants along one side of a public road shall not be designated to serve developments that are sited across the other side of the public road, except for a one-way or two-way lanes road.

EXPLANATIONS & ILLUSTRATIONS

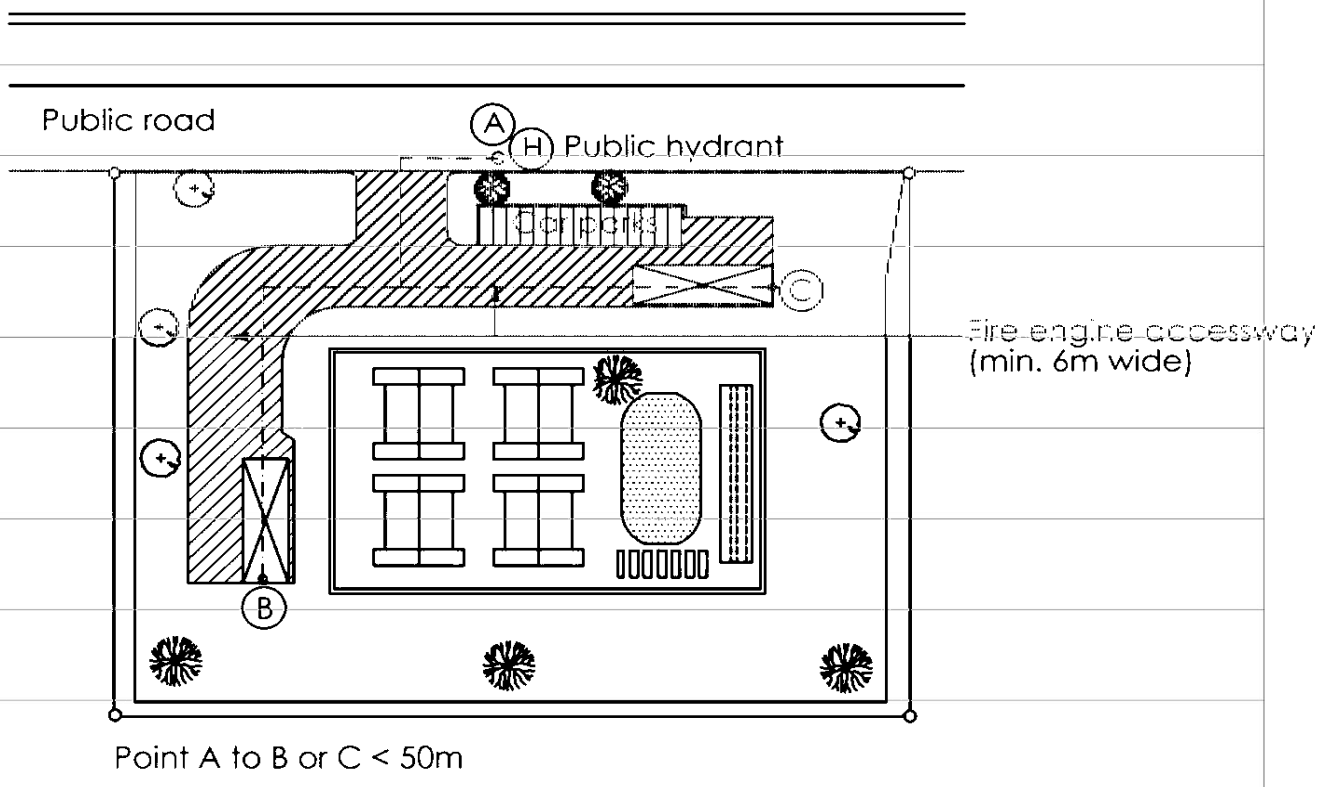

Diagram 4.4.1(a)-1

The distance of 50m is measured horizontally along the fire engine access way.

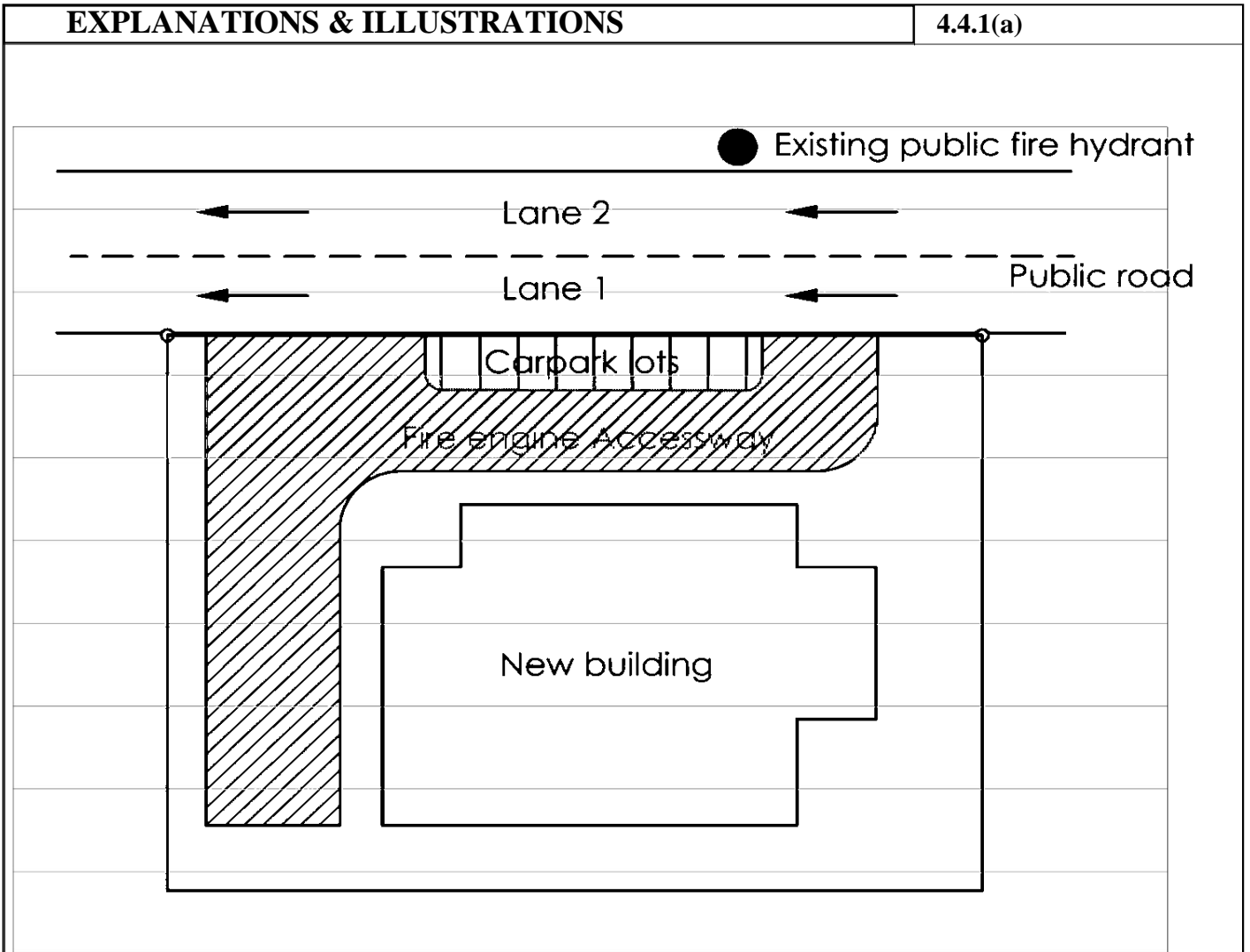

Diagram 4.4.1(a)-2

All developments shall be provided with its own private hydrant. In the case of a new development where the existing public hydrant is within the stipulated coverage, such hydrant can be considered. To qualify for the relaxation, the existing public hydrant shall be within an unobstructed distance of 50m to every part of a fire engine access road and/or an access way.

If the existing public hydrant is sited across the other side of the public road, the said public hydrant is not allowed to serve the development unless it is sited not further than 2 lane width of the public road regardless of direction of traffic flow.



(b) In situations where more than one private hydrants are required, the hydrants shall be located along the fire engine access road and/or an access way such that every part of the access road and/or access way is within an unobstructed distance of 50m from any hydrant (see diagram 4.4.1(b)).

EXPLANATIONS & ILLUSTRATIONS

4.4.1

No illustration.

(c) Siting and types of fire hydrants shall comply with the requirements stated in BS 9990.

EXPLANATIONS & ILLUSTRATIONS

4.4.1

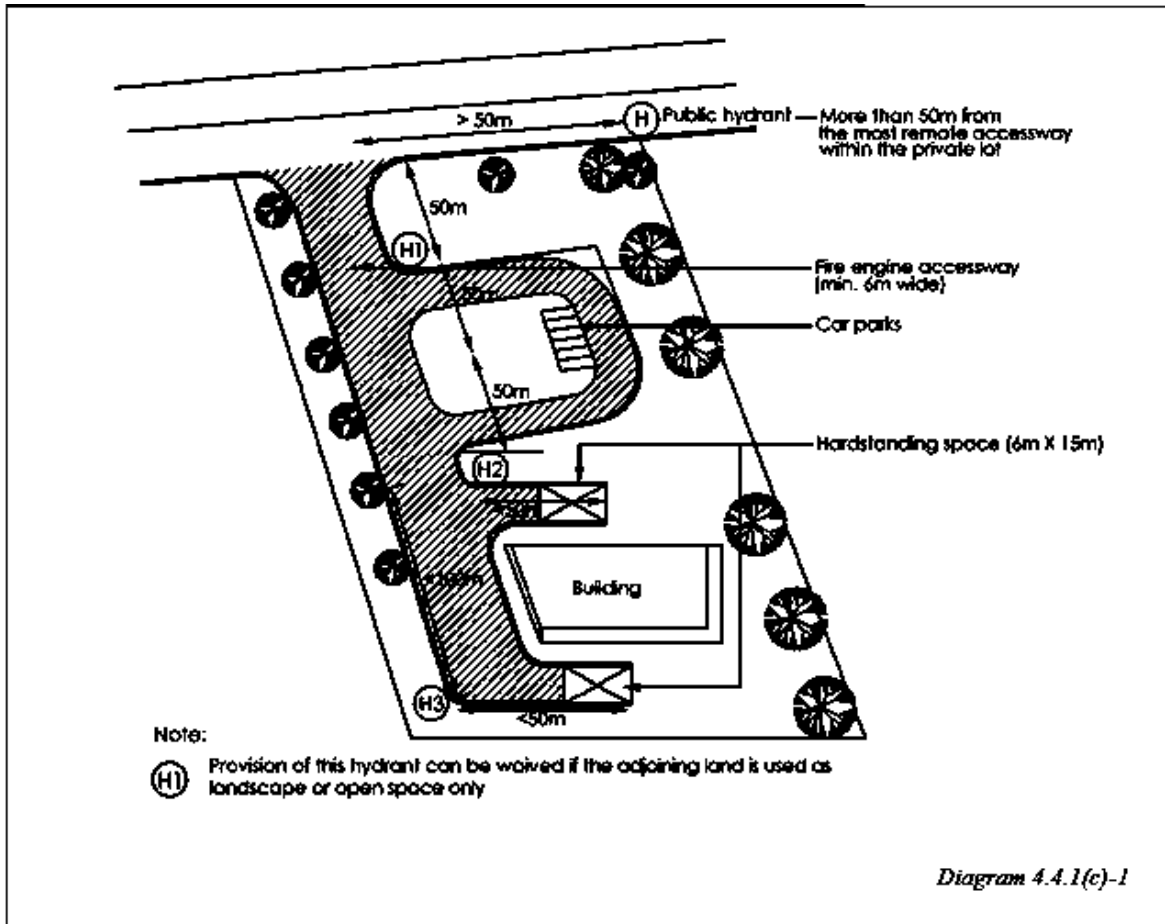

Hydrant H1 is not required if the adjoining land is maintained as open space. However, if the land is later developed for houses, provision of hydrant would be required.



EXPLANATIONS & ILLUSTRATIONS

4.4.1(c)

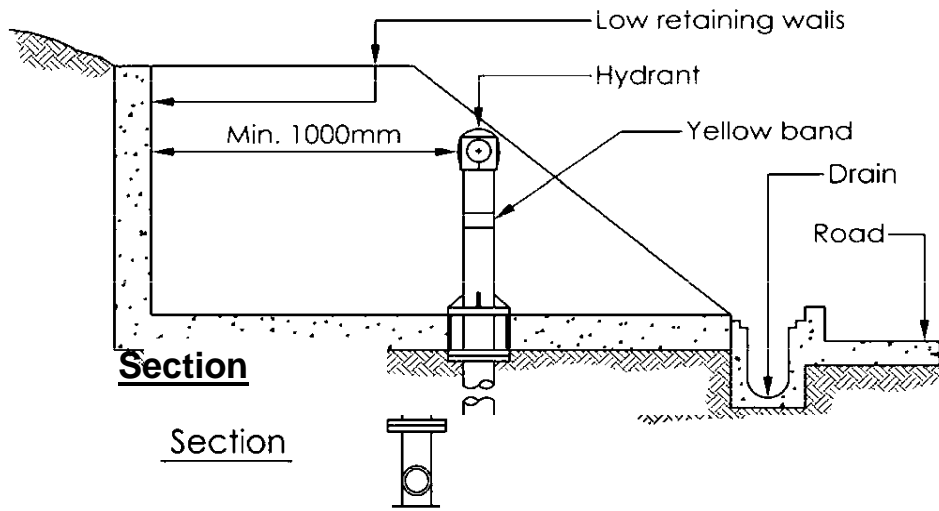

Diagram 4.4.1(c)-2

The required minimum of 6m clearance between the building or retaining wall/boundary wall and fire hydrant can be reduced to minimum 1000mm. The above relaxation is to allow the minimum working space for hose connection.

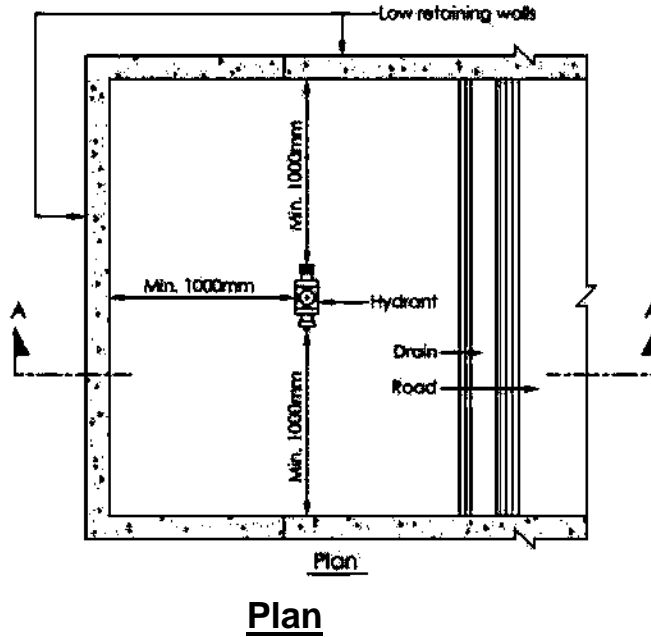

Diagram 4.4.1(c)-3



EXPLANATIONS & ILLUSTRATIONS

4.4.1(c)

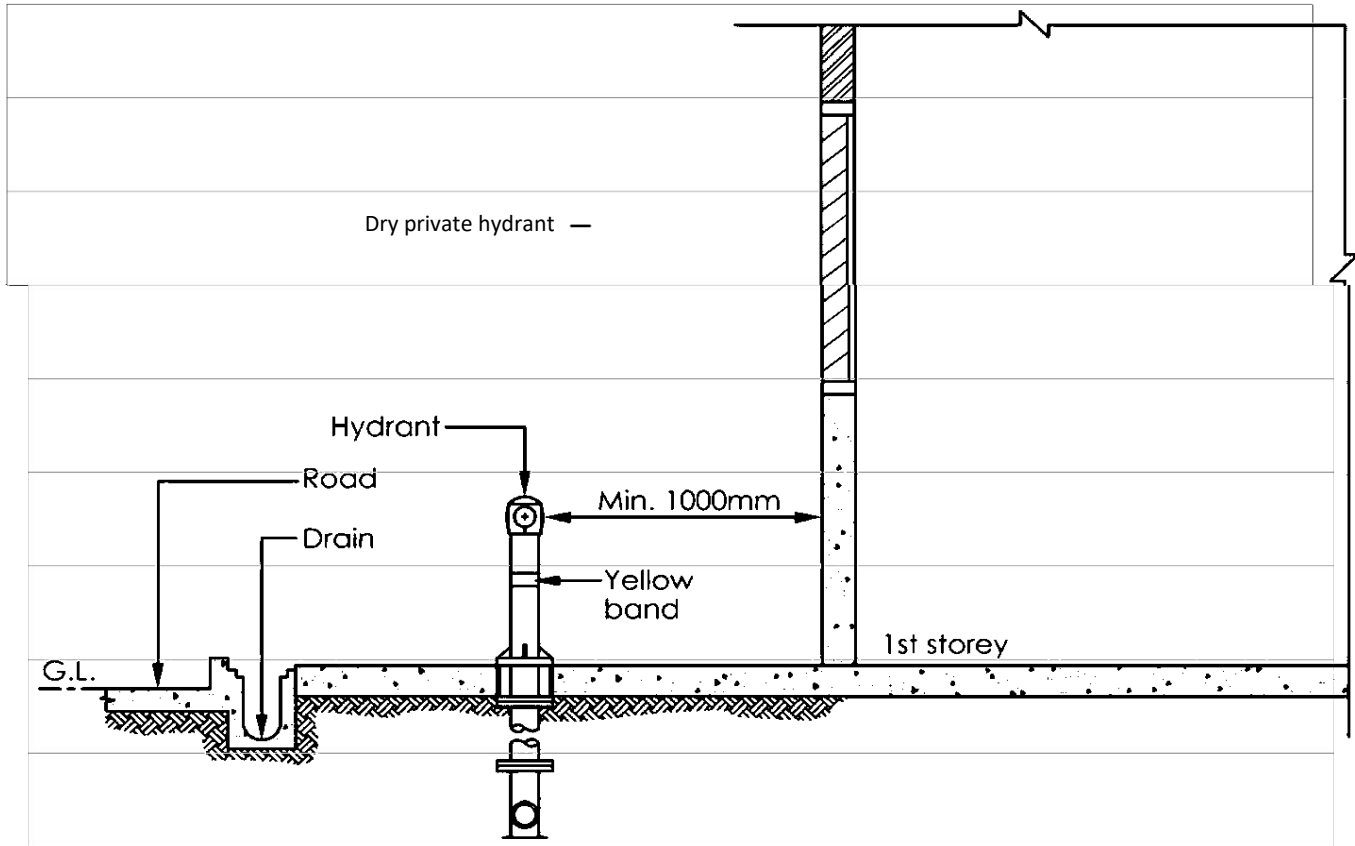

Diagram 4.4.1(c)-4



- (d) For a building that is required to have island site access way under clause 4.2.2(b), the hydrant pipe shall be a ringed system. Isolation valves shall be provided on the hydrant ring such that any section of ring, with a maximum of one fire hydrant, can be isolated when required for maintenance without affecting the water supply (both designed pressure and flow) to the other fire hydrants. Locking device shall be provided to lock the valves in open position during normal operation.

EXPLANATIONS & ILLUSTRATIONS

4.4.1

No illustration.

Where the building is provided with island site fire engine access way, the hydrant pipe serving hydrants within development shall be a ringed water supply system. This system to hydrant will ensure un-interrupted water supply to facilitate fire-fighting operation during a fire emergency. Isolation valves shall be provided at strategic locations such that any section of the ring (only one fire hydrant) scheduled for maintenance or repair shall not affect the water supply (pressure and flow) to other connected private hydrants. The hydrant ring pipe should be run above-ground or laid beneath earth. Where it is not practical (e.g. At road crossing), the section of underground hydrant pipe shall be appropriately supported to prevent any pipe leakage due to movements of vehicles above. Additional isolation valves should be provided at pipe sections just before and after the road crossing.



CHAPTER 4

4.4 PRIVATE FIRE HYDRANT

4.4.2 Water supply for private hydrant

Provision of water supply for private hydrant system where required by this Code shall comply with one of the following requirements:

- (a) Private fire hydrants installed at reduced level 125m and below can receive direct supply from public water main. If the flow and pressure from the public water mains cannot meet the hydrant requirements, a storage tank of sufficient capacity with the requisite pumping facilities shall be provided. Private fire hydrants receiving direct supply from public water mains shall comply with:
 - (i) The nominal bore of the hydrant pipe and the bulk water meter shall not be less than 150mm in diameter; and
 - (ii) The running pressure/flow at the hydraulically most unfavourable hydrant of the private hydrant system shall comply with the following :
 - (1) Running pressure $\geq 0.9 \times$ (running pressure of the nearest public hydrant – pressure drop across the bulk water metre); and
 - (2) Flow Rate $\geq 0.9 \times$ water flow of the nearest public hydrant or \geq total flow demand (as required in Table 4.4.2) of the private hydrant system, provided the running pressure at the remotest private hydrant is greater than 2 bars

Note:

In calculating the frictional loss for the private hydrant system, the design flow rates shown in Table 4.4.2 shall be used.

Pressure drop across bulk water metre shall not be more than 1bar.

EXPLANATIONS & ILLUSTRATIONS

4.4.2

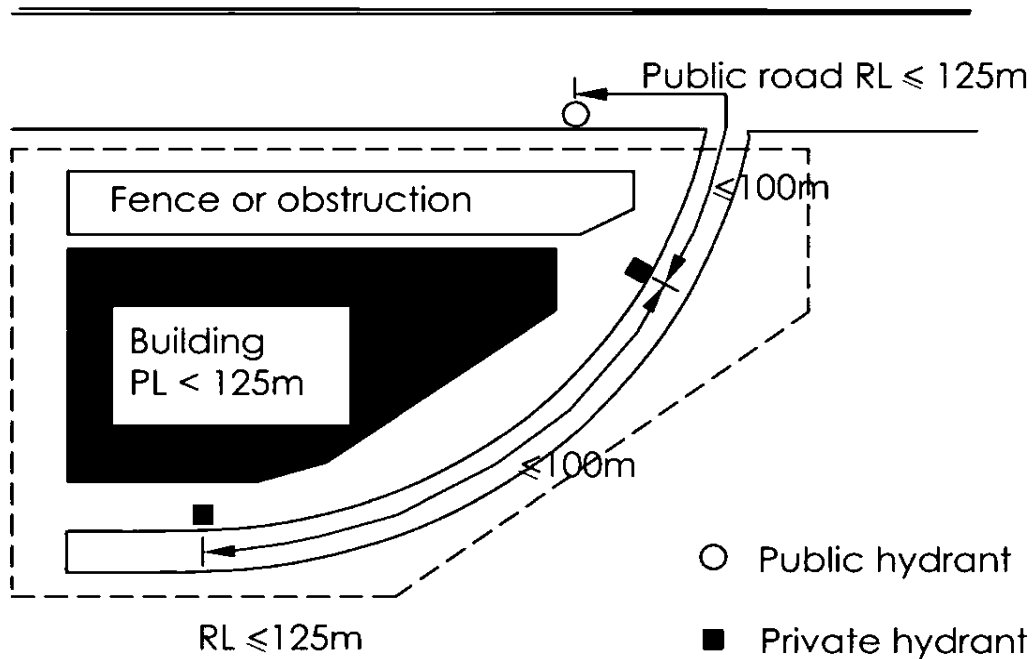

Diagram 4.4.2 (a)

There is a need to differentiate at RL 125m as public mains located at above RL 125m would not be able to provide the required water pressure. It is important that hydrants annotated in building plan should be given their respective reduced levels.

1. Private hydrants that are sited at RL < 125m are allowed to take the water supply from public water mains, which likewise should not be located above RL 125m.
2. There is a need to observe the RL < 125m as the public water mains located at above RL 125m would not be able to provide the required pressure and flow rate for fire-fighting purposes.

It is therefore important that private hydrants and the supply public waterman annotated in building plans should be given their respective reduced levels.



EXPLANATIONS & ILLUSTRATIONS	4.4.2
---	--------------

Allowable losses in hydrant pipe

(Using Hazen-William's formula)

$$\frac{6.05 \times Q^{1.85} \times 10^7}{C^{1.85} \times d^{4.87}}$$

$P =$ **C** ^{1.85} **x** **d** ^{4.87}

<i>Q</i>	<i>l/s</i> 27	<i>l/min</i> 1620
<i>d</i>	<u><i>mm</i></u> 150	<u><i>m</i></u> 0.15
<i>c</i>	140	
<i>P</i>	0.14173 kPa/m	

<i>Pressure after bulk meter (P1)</i>	300 kPa
<i>Length of hydrant pipe</i>	180 m
<i>Number of bends</i>	4 nos.
<i>Equivalent length of bends</i>	30 m
<i>Total equivalent length</i>	210 m
<i>Pressure loss in pipe</i>	29.76296 kPa
<i>Pressure available at remote hydrant (P2)</i>	270.237 kPa
<i>% loss in pressure</i>	0.90079 Not < 90%



- (b)(i) Where there is only one private hydrant in the plot that is located above reduced level 125m; and
- (ii) this hydrant is not the sole hydrant within 50m from any breaching inlet(s) feeding into fixed water based fire fighting system(s) including automatic sprinkler systems, dry riser systems, and wet riser systems for the building(s) standing on this plot of land;

This hydrant can be in the form of a "dry" hydrant. A "dry" hydrant shall be connected to a 150mm diameter dry pipe, which shall be connected at the other end to a four-way breaching inlet. This breaching inlet shall be within 18m from any access way or fire engine access road having minimum 4m width and within 50m from any wet hydrant, private or public. The private dry pillar shall be painted in "yellow" and labelled "dry" on the hydrant pillar. A signage indicating the location of breaching inlet shall be positioned next to the dry private hydrant.

EXPLANATIONS & ILLUSTRATIONS

4.4.2

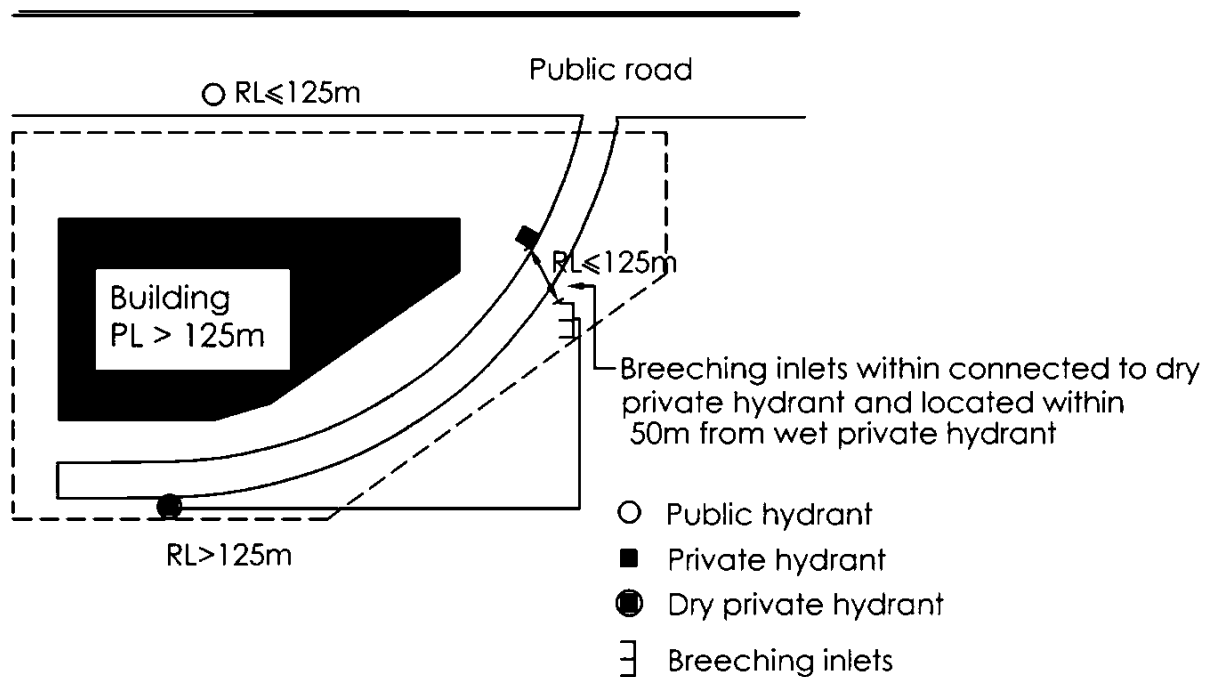

Diagram 4.4.2(b)

"Dry" hydrant is equivalent to the provision of dry rising main. Care should be taken to prevent accidental damage by vehicle etc to the horizontal run of the pipe aboveground.

The dry pipe should be differently identified on site. The provision of dry hydrant is a relaxation as all hydrants are required to be fed with water at all times. This is allowed as the fire fighters could use other hydrants located below RL 125 which are within 50m from the breaching inlets.



(c) Where more than one private hydrant are located above reduced level 125m within the same plot, storage and pumping arrangements of water supply to these specified hydrants shall comply with those for wet rising mains stipulated in BS 9990 and Table 4.4.2 – Water Supply & Storage Requirements For Private Hydrant. The water supply for hydrants serving residential and non-residential developments shall be as follows:

Table 4.4.2 – Water supply & Storage requirements For Private Hydrant

Purpose Group/Requirement	Purpose Group I & II	Purpose Group (*) III, IV, V, VII	Purpose Group (*) VI & VIII
Minimum running pressure	2 bars	2 bars	2 bars
Minimum flow rate	27 L/s	<1000m ² - 38L/s <5000m ² - 57L/s <10000m ² - 76L/s (57L/s if sprinkler protected)	500m ² - 38L/s <5000m ² - 57L/s <10000m ² - 76L/s (57L/s if sprinkler protected)
Minimum duration	45 mins	Additional 19L/s for subsequence 5000 m ² 45 mins	Additional 19L/s for subsequence 5000 m ² 90 mins

* Based on the floor area of the largest compartment in the building

EXPLANATIONS & ILLUSTRATIONS

4.4.2

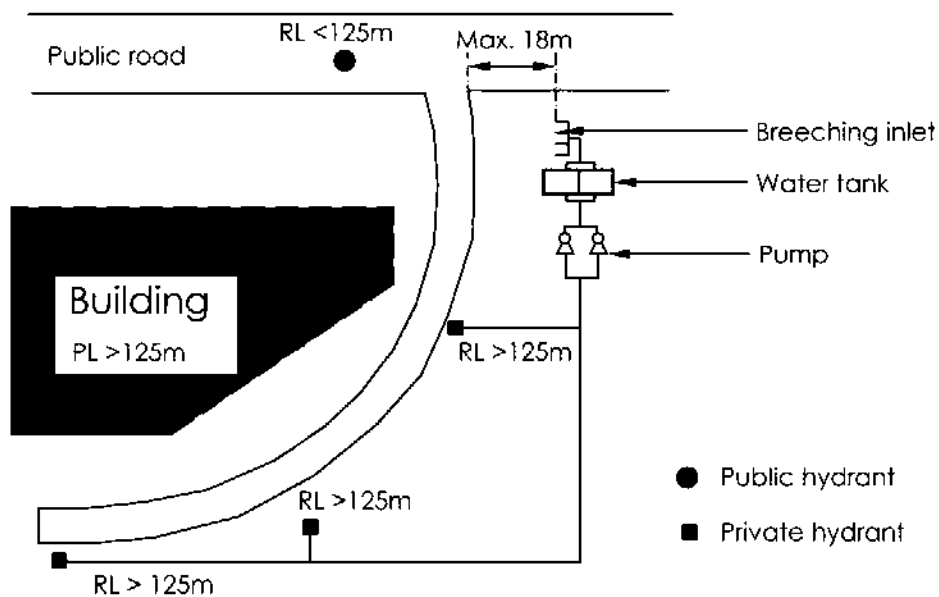

Diagram 4.4.2(c)-1



EXPLANATIONS & ILLUSTRATIONS

4.4.2(c)

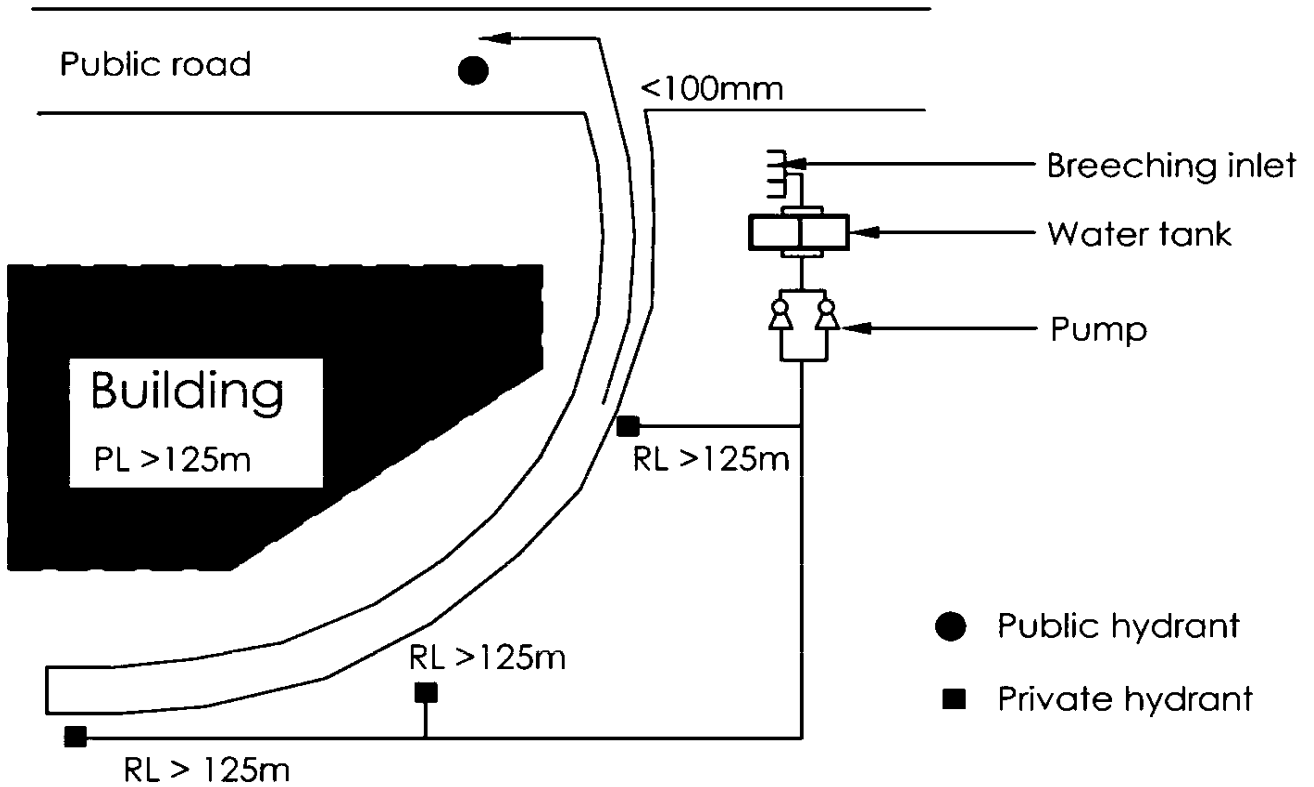

Diagram 4.4.2(c)-2

The hydrants are required to be charged with water all the times so that fire fighters could use them for feeding the breeching inlets and for fire-fighting purposes.



CHAPTER 4

4.4 PRIVATE FIRE HYDRANT

4.4.3 Protection of hydrant mains in buildings

All hydrant mains which pass through a building shall have its full length within the building protected with fire resistance construction complying with Cl.3.8.7 (c) of at least the same fire resistance as the element of structure, provided the following requirements are complied with:

- (a) The hydrant mains shall be located in common circulation areas, such as car parking spaces and driveways; i.e. they shall not pass through private or confined spaces;
- (b) No services (except sprinkler pipes) shall be located above or crossing over the hydrant mains;
- (c) The hydrant mains shall be located away from explosion risk areas; and
- (d) The protective enclosure to the hydrant mains shall be labelled with the words “HYDRANT MAIN” of minimum 50mm height at suitable intervals.

EXPLANATIONS & ILLUSTRATIONS

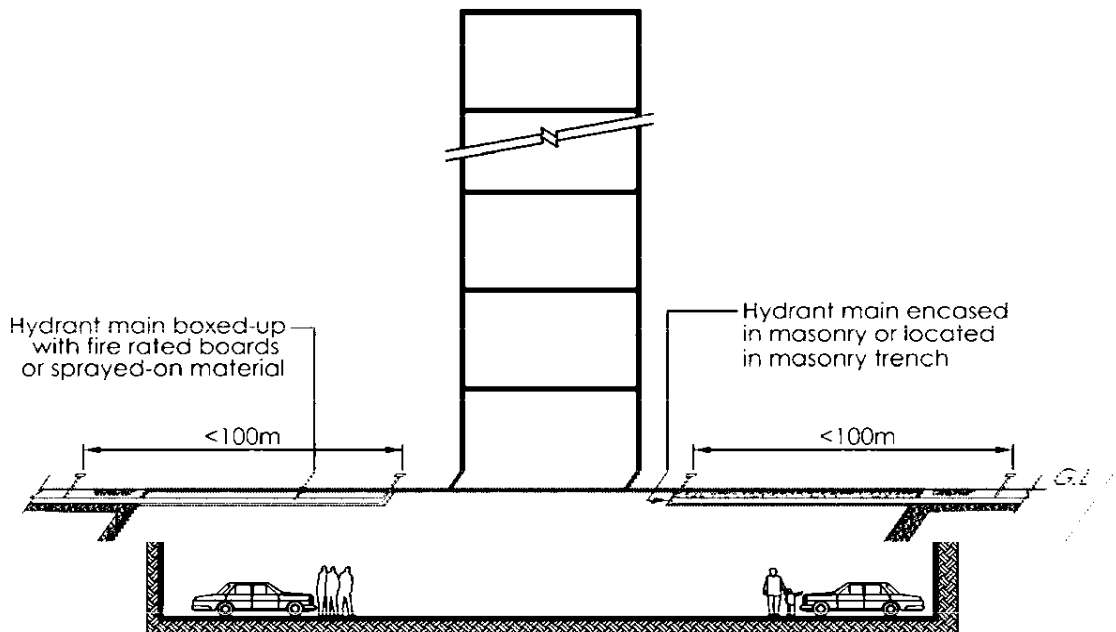

Diagram 4.4.3-1



EXPLANATIONS & ILLUSTRATIONS

4.4.3

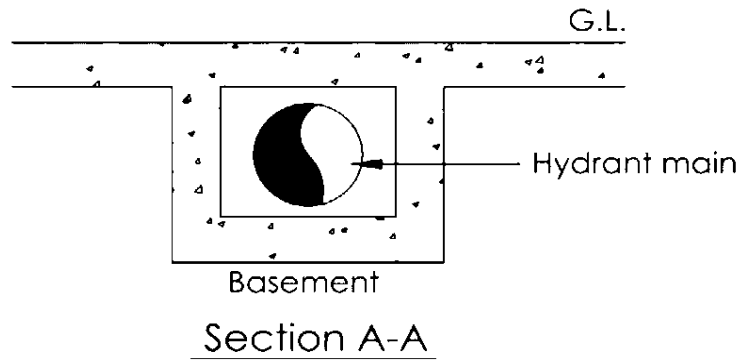

Diagram 4.4.3-2

Hydrant main supplying water to hydrant shall be appropriately protected to prevent any damage arising from fire or mechanical impact from moving objects or the carrying out of addition/alteration works within the building. Water main, which is damaged, would affect the water supply to the hydrant. This would in turn affect the fire-fighting operation in an emergency. Hydrant main protected with dry protection e.g. boxed-up with fire rated boards or sprayed on materials shall only be allowed to be routed or located in basement or floor protected by sprinkler system.